



Owners Manual

1400JF & 1400JFL

Aerating Fountain



Contents

Safety	... pg2
General Instructions	... pg2
Parts & Tools	... pg3
Assembly & Installation	... pg4
Options & Pattern Sizes	... pg7
C-25 Timer Control	... pg8
Maintenance Recommendations	... pg9
Warranty	... pg10
Troubleshooting Tips	... pg12
Replacement Parts Diagram	... pg14
Customer Repair Form	... pg15
Registration Information	... pg16



3020379
ANSI/UL 778, 5th Ed. 2010
CAN/CSA C22.2 No. 108-M89
UL 50, 11th Ed. 1995

Kasco Marine, Inc.
800 Deere Rd.
Prescott, WI 54021
PH (715) 262-4488
FAX (715) 262-4487
www.kascomarine.com

Rev. 07/07/15

Thanks

We at Kasco Marine, Inc. would like to both thank and congratulate you on your purchase of the 1400JF Aerating Fountain. We appreciate you choosing Kasco and for your purchase. Your decision to purchase Kasco's 1400JF Aerating Fountain will not disappoint you. The 1400JF Aerating Fountain will be a great addition to your body of water. It will help improve the water quality by adding much needed oxygen and circulation. It will also enhance the aesthetics of the pond or lake with the 5 interchangeable fountain patterns. The lighting package (if purchased) will illuminate your fountain for beauty day and night. We thank you for choosing Kasco for your fountain needs and want you to be completely satisfied with your purchase.

Safety

Please read and follow these extremely important safety and handling instructions for your Kasco equipment. Following these instructions will help ensure your safety and the quality performance of your equipment.

- Under NO circumstances should anyone enter the water with the electrical equipment plugged in and/or in operation. All Kasco 1400JF and 1400JFL equipment is ETL approved to UL and CSA standards for safety in water and all fountain models included control panels with GFI protection. However, it is NEVER recommended to enter the water with the equipment in operation.
- Caution should be used when dealing with any electrical and/or moving equipment.
- NEVER run the unit out of water. It will damage the seals and create a dangerous situation for the operator.
- Extreme caution should be used around wa-

ter, especially cold water, such as in Spring, Fall, and Winter, which poses a hazard in and of itself.

- NEVER lift or drag the fountain by the power or light cord. If you need to pull the unit to the side of the pond, use the anchoring ropes.
- Do not use waders in deep ponds/lakes or ponds/lakes with drop-offs, drastic slopes, or soft bottom material.
- Do not use boats that tip easily for fountain installation, such as a canoe, and follow all boating safety rules and regulations, including wearing a PFD (Personal Flotation Device).
- The fountain is supplied with an internal grounding conductor and a grounding-type attachment plug. To reduce the risk of electrical shock, be certain that the fountain is plugged into the C-25 Control Box supplied by Kasco and that the C-25 is plugged into a properly grounded, grounding type receptacle.

General Instructions

INSPECT THE SHIPMENT

Immediately inspect your Kasco Fountain shipment for any visible damages. Also cross reference the parts supplied with the Parts Included list to check for shortages. Shortages should be reported immediately to your Kasco Marine distributor or representative and damages reported to your carrier and Kasco Marine.

CAUTION

WARNING: Under NO circumstances should anyone enter the water with the unit in operation. Always operate the unit in the water and keep people and objects clear of the propeller. Do not lift or pull the unit by the electri-

cal cord. Always use extreme caution around electrical equipment and water situations.

ASSEMBLY & INSTALLATION

Please see the proper Assembly and Installation Instructions enclosed in this manual. Each is specific for your model and size of Fountain. Note: Use the nylon tie provided to help keep the power cords for the unit and lights free of the propeller by tying the cords and one of the mooring ropes together. Note: It is extremely important to test the GFI breaker in the control panel upon each installation/reinstallation of the unit to ensure proper functioning.

WARRANTY

Kasco Fountains are the result of over 35 years of design and engineering. Kasco products are built to withstand the toughest conditions. Kasco Marine backs each 1400JF Fountain with a 2 Year Warranty. This warranty covers any and all manufacturers defects within 2 years from the date of purchase (See Warranty section). Please register your Fountain online at:
www.kascomarine.com (under the Technical Tab)

USE AND OPERATION

Kasco Fountains are designed and engineered for continuous duty, such as on fish farms or other aquaculture applications, or on-demand use, as needed in a recreational water feature.

During flotation operation, the water is pulled from 360° around the unit and from below the unit. The water is pulled upward and thrust through the flotation collar into the air.

Your Kasco Marine Fountain is ready for immediate use (after installation). The motor and ball bearings are submerged in oil and no

further lubrication is needed. Make sure to keep the motor housing clean from hard water deposits and/or algae. (See Maintenance Recommendations)

It is extremely important that proper and sufficient voltage (120V) is supplied to the Fountain motor. Each Fountain is supplied with a UL and CSA approved C-25 GFI Protected Control Box. The Fountain is to be plugged into the C-25 outlet labeled "UNIT" and the C-25 plugged into a properly grounded receptacle (See C-25 Instructions).

Kasco Fountains are lightweight, energy efficient, and easy to install and operate. We strive to produce products that exceed customer expectations. We hope you enjoy your Kasco Fountain.

UNIT STORAGE

When storing units during the offseason, it is important to store them upside down if they are going to be sitting for long periods of time. Units that sit upright on a shelf for many months, or even years have a greater likelihood of seals drying out. Storing upside down will ensure oil is lubricating the seals and prevent drying.

Parts & Tools

- 1400JF Aerating Fountain (Assembled in box) (1)

NOTE: If lights are not purchased or included, the cord and Transformer on the left side of the picture will not be included with the shipment.



UNIT SPECS

Model	Voltage	Amps	Lock rotor amps
1400JF	120 volts	3.1	10

Assembly & Installation

STEP ONE

Remove all contents from package and place on a clean, flat surface. Inspect the shipment for any damages. If damages are found, immediately notify your carrier and your Kasco Marine, Inc. representative. Next, cross reference the parts included in the shipment with the Parts Included sheet in this manual. Make sure you have all the parts needed. If any shortages are found, contact your Kasco representative immediately.

- Interchangeable Nozzle Heads (Osprey Installed) (5)



- Braided 15' Nylon Mooring Ropes (2)
- 1/4-20 x 7/8" Long Fillister head screw for Nest patterns (1)
- C-25, 120V Control Unit (1)
- Nylon Cable Tie for securing cords and a mooring rope (1)

STEP TWO

Locate and unwind the two braided nylon ropes included with the shipment. There are two molded Rope Holes on opposite sides of the float attached to the fountain assembly. Tie one end of a rope to one rope hole with a secure knot. Be sure not to leave too much of a tail after the knot. Repeat with the other rope on the other Rope Hole.

TOOLS & SUPPLIES NEEDED

- Anchors or stakes for installing unit (2)
- Flat Head Screw Driver
- Philips head screw driver for mounting C-25 and Transformer (if lights are included) and installing nozzles
- 120V Electrical Supply near pond on a post with room for mounting the C-25 and Transformer (if lights are included)
- Two 12" pieces of 1" galvanized pipe for weighting ropes (optional)
- #6 x 3/4" long or longer screw for mounting the Transformer (if lights are included) (1)
- #10 x 1" long or longer screw(s) for mounting the C-25 (3)

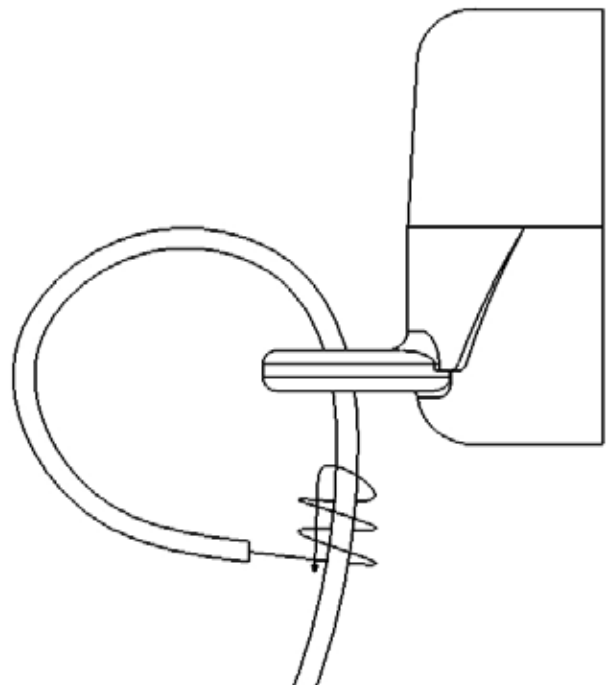

STEP THREE

Locate the 5 nozzles included with the shipment (the Osprey nozzle is already installed on the fountain, along with the Upper Pump Housing). Using the Nozzle Options diagram on page 7, determine which pattern is desired and the corresponding nozzle. If the Condor or Falcon patterns are desired, you must remove the Osprey Nozzle by removing the 1" Self Tapping Phillips Head Screw. Replace the nozzle with either the Condor or Falcon, re-insert the 1" Self Tapping Phillips Head Screw and tighten until snug (Diagram A). If either the Eagle's Nest or Hawk's Nest patterns are desired, you must remove the Upper Pump Housing.

First, remove the 4 Upper Pump Housing screws. With the Osprey nozzle still attached to the Upper Pump housing, pull the osprey nozzle and Upper housing up together. Finally, remove the 3/8" Fillister head, plastic set screw in the top of the 4 Blade Prop. Place a slight amount of pressure on the new nozzle when in place and tighten the 1/4-20 x 7/8" Fillister head screw until snug. Do not over tighten. (Diagram B)

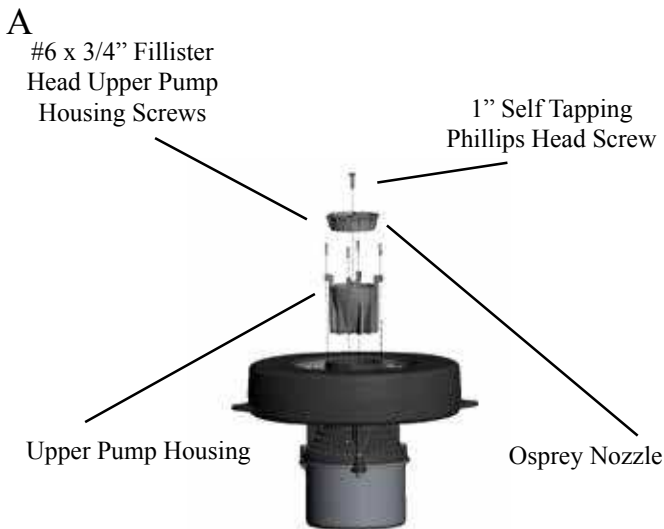

B

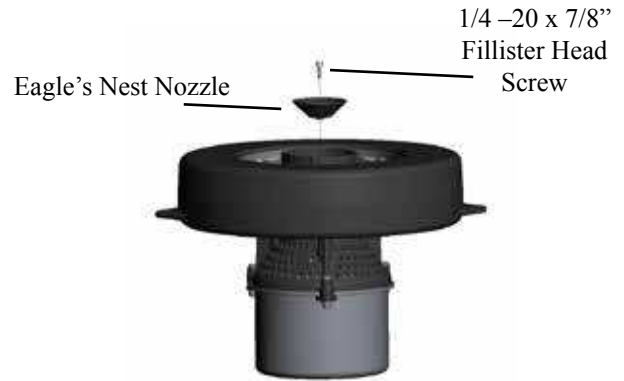

STEP FOUR

Install the Fountain into the pond/lake in at least 12" of water so the unit is floating freely. Support the weight of the unit with the ropes and/or the float while setting it into the water, DO NOT LIFT BY THE CORD. Use the nylon tie to secure both cords and an adjacent mooring rope together about 1 foot from the float to prevent twisting or getting caught in the unit. Secure the ends of the cords to the post at the power supply so the ends do not get dragged into the water.

STEP FIVE

Determine how to anchor or secure the unit in the pond. You may want to use weights at the end of each rope (cinder blocks work well) and sink them to the bottom or secure the ropes to the shoreline by tying them to a stake or placing a rock on top of the ropes.

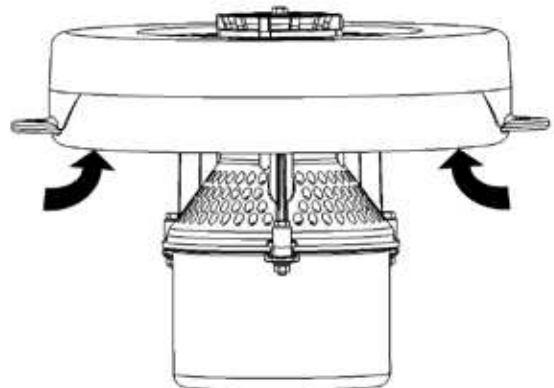

STEP SIX

Use the ropes to position the Fountain in the desired location in the pond/lake. Anchor the ropes or secure them to the shoreline so the ropes are free of slack, but not tight. To prevent twisting of the unit due to torque, you should place the anchor at least 3 feet from the float for each foot of depth (Ex. A 3 foot deep pond would require an anchor 9 feet horizontally from the float.) For ease of removal, you may choose to keep at least one anchor within reach from shore, just below the water's surface.

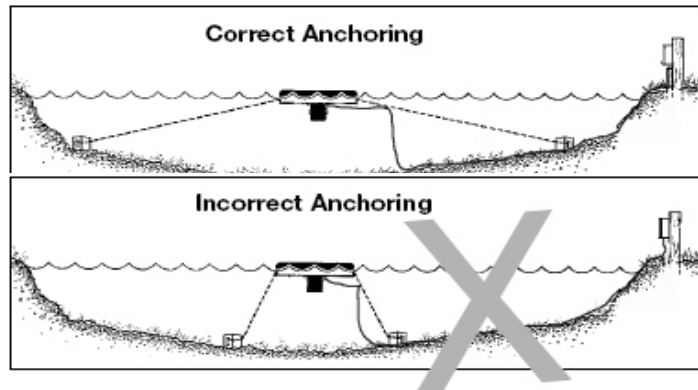

STEP SEVEN

(ALTERNATE INSTALLATION)

In ponds where the water level fluctuates significantly, you may need to suspend a small weight (12" of 1" galvanized pipe works well) at the mid-point of the rope to take up any slack as the water level drops. The weight should be light enough so the Fountain can rise as the water level rises. This can also help hide ropes by sinking them further below the surface.

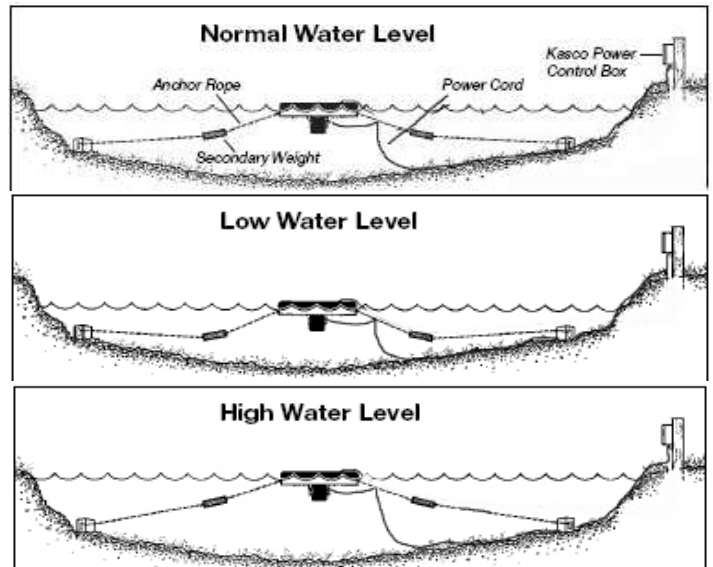

STEP EIGHT

Install the C-25 on the post with the power supply. Use up to three #10 x 1" long or longer screws and the molded screw placements on the C-25. NOTE: The C-25 must be hung upright in order to be waterproof. Install the Low Voltage Transformer (if lights are included) on the same pole below the C-25 with the one #6 x 3/4" long or longer screw. NOTE: The Transformer must be hung upright in order to be waterproof.

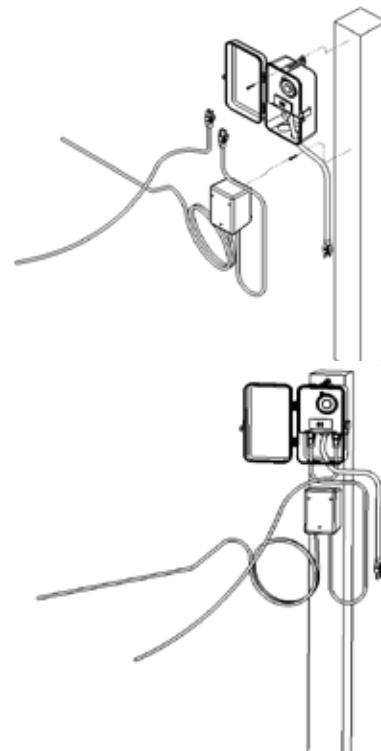

STEP NINE

Set C-25 Timer to desired ON and OFF times per the C-25 Instructions on page 8. Make sure to test the GFI using the Test Button located on the outlet before turning the equipment on and every 30 days thereafter. Plug the 1400JF cord into the C-25 outlet labeled "UNIT". If lights are included, plug the Transformer cord into the C-25 outlet labeled "LIGHT".

STEP TEN

Plug the C-25 into the 120V power supply on post and ENJOY YOUR NEW KASCO 1400JF AERATING FOUNTAIN.

Options & Pattern Sizes

The unique center set design of Kasco's 1400JF Aerating Fountain nozzles offers the best clog-resistance and interchangeability available. To achieve the pattern you desire, simply select the appropriate nozzle according to the accompanying photos and install using the proper bolt or screw into the fountain tube or upper pump housing (depending on which nozzle chosen). Be sure to snug the bolt or screw to ensure the correct pattern display and size.

NOTE: Pattern sizes listed are approximate. Variations in voltage caused by regional electrical differences or voltage drop due to long power cords may result in reduced pattern sizes.

Osprey:



Produces a wide arch of water 3.5 feet high by 7 feet in diameter.

To use this nozzle, you must have the upper pump housing in place. This nozzle has flared outer fins and the number 1 molded on top portion of the nozzle. Comes installed on unit.

Condor:



Produces a two-tiered arch of water with an inner arch 4 feet high by 4 feet in diameter and an outer arch 2 feet high by 10 feet in diameter.

To use this nozzle, you must have the upper pump housing in place. This nozzle has flared outer fins and has the number 2 molded on the top of the nozzle.

Falcon:



Produces a narrow arch of water 4 feet high by 4 feet in diameter.

To use this nozzle, you must have the upper pump housing in place. This nozzle has nearly vertical outer fins and the number 3 molded on the top of the nozzle.

Eagle's Nest:



Produces a wide "V" pattern of water 3.5 feet high by 10 feet in diameter.

This nozzle does not use the upper pump housing. It has the number 4 molded near the screw collar of the nozzle.

Hawk's Nest:



Produces a narrow "V" pattern of water 3 feet high by 7 feet in diameter.

This nozzle does not use the upper pump housing. It has the number 5 molded near the screw collar of the nozzle.

Upper Pump Housing:



Must be installed and used with the Osprey, Condor, and Falcon nozzles. Must be removed to use the Eagle's Nest and Hawk's Nest nozzles.

Hint: Keep the osprey nozzle attached to the

upper pump housing to help you pull the upper pump housing out of the fountain tube for cleaning or nozzle changes.

C-25 Timer Control

Portable Timer with Ground Fault Interrupter

IMPORTANT

This portable timer is designed for CONTROLLING the connected equipment only. Unplug timer before servicing the unit or the equipment it controls. For maximum protection against electrical shock hazard, perform test procedure on G.F.C.I. at least once a month. Mount at least 5 ft. from open water.

G.F.C.I. TEST PROCEDURE

The G.F.C.I. should be checked every month to make sure that it is operating properly. Just follow the simple instructions below. It is recommended to maintain a maintenance diary of your monthly safety check.

1. Push TEST button, RESET button should pop out from inner surface. This should result in power being OFF at the outlet protected by the G.F.C.I. Verify by plugging a test lamp into the outlet. Be sure the timer is in the ON position.

2. If the G.F.C.I. tests okay, restore power by pushing the RESET button back in. THE RESET BUTTON MUST BE PUSHED FIRMLY AND FULLY INTO PLACE UNTIL IT LOCKS AND RE-MAINS DEPRESSED AFTER PRESSURE HAS BEEN REMOVED.

DANGER: IF RESET BUTTON DOES NOT POP OUT, IF TEST LAMP REMAINS LIT WHEN RESET BUTTON DOES POP OUT, OR IF THE G.F.C.I. FAILS TO RESET PROPERLY, DO NOT USE TIMER! CONTACT A QUALIFIED SERVICE TECHNICIAN!

Failure to use the C-25 with Kasco Fountains will void the warranty and cause the Fountain

to not be listed to UL and CSA standards via ETL.

UNDER NO CIRCUMSTANCES SHOULD ANYONE ENTER THE WATER WHEN A UNIT IS IN OPERATION!

TIMER-OPERATION INSTRUCTIONS

C-25 Control Box will turn the aerator/fountain ON & OFF with the TIMER. Kasco lights will turn ON with the PHOTO EYE and OFF with TIMER. C-25 Control Box is to be used with Kasco Approved Lights ONLY!

- See Control panel label for instructions to set the timer
- Plug aerator/fountain cord into the RIGHT hand outlet (labeled UNIT).
- Plug transformer light cord into LEFT hand outlet (labeled LIGHT).

Maintenance Recommendations

** Under No Circumstances should anyone enter the water while a fountain is operating.

** Please keep the original box for maintenance shipping.

The following maintenance procedures can be utilized to ensure many years of quality performance from your Kasco Fountain and reduce the need for more costly repair work.

PROPER INSTALLATION: Proper installation of Kasco equipment will include a power source with ground fault interruption. For Fountain models, the C-25 control (120V) included with the unit has built-in ground fault interruption that is sufficient. Ground fault interrupters are a safety feature that can also alert you to electrical leaks in the equipment.

It is extremely important to test the GFI upon installation, each reinstallation, and monthly thereafter to ensure proper operation. If you have repeat, consistent trips on your ground fault, the equipment should be disconnected and removed from the water. The power cord should be inspected for damage and you should call Kasco Marine at 715-262-4488 for further instructions or email Kasco at service@kascomarine.com.

OBSERVATION: Operating equipment should be observed on a regular basis (daily, if possible) for any reduction or variation in performance. If a change in performance is observed, the equipment should be disconnected from power and inspected for any material that may have clogged the system or wrapped around the shaft of the motor, especially plastic bags and fishing line. Even though Kasco Aerators and Fountains are among the most clog-resistant on the market, it is impossible to protect against all items that can clog equipment and still maintain a flow of water. These materials can be very damaging to the equipment under continued operation and must be removed as soon as possible. **ALWAYS UNPLUG THE UNIT BEFORE ATTEMPTING TO REMOVE CLOGS.**

WINTER STORAGE: In regions where there is significant freezing in the wintertime, the fountains should be removed from the water to protect them from the expansion pressure of the ice. In many areas, fountains will keep some amount of ice open through the winter. However, when the water is thrust into the air, it is exposed to the colder air temperatures longer and can actually make ice thicker on the pond/lake. Storage over winter is best in a location that is out of the sun and cool, but above 32°F. When storing units during the offseason, it is important to store them upside

down if they are going to be sitting for long periods of time. Units that sit upright on a shelf for many months, or even years have a greater likelihood of seals drying out. Storing upside down will ensure oil is lubricating the seals and prevent drying.

CLEANING: Fountains should be removed from the water at least once per year (at the end of the season in cold climates) to clean the exterior of the system, especially the stainless steel motor housing (can). The motor housing is the surface that dissipates heat into the water and any algae, calcium, etc. build-up will become an insulator that blocks heat transfer. In warmer regions it is recommended that the motor is removed and cleaned at least two to three times per year depending on conditions. In most cases a power washer will be sufficient if the unit and algae are still wet.

SEAL AND OIL REPLACEMENT: This is a sealed motor assembly and seals will wear out over time (similar to break pads on a car). Replacement of the seals and a change of oil after three years may add longevity to the operation of the motor, saving you the cost of more expensive repairs. In warmer climates where the fountain runs most or all of the year, it is a good idea to replace seals more regularly than you would need to in colder climates where the unit is removed from the water for several months.

Seal replacement and all other repair services should be performed by Kasco Marine or a Kasco trained Authorized Repair Center. Any alterations or changes made to Kasco units by an unauthorized source will void the warranty. This includes tampering with the unit, power cord, and/or control box. Please contact Kasco Marine, Inc. at 715-262-4488 for your nearest Authorized Repair Center.

Warranty

2 Year Limited Warranty: Kasco® Marine, Inc. warrants this Fountain to be free from defects in material or workmanship (except for the ropes, power cord, and propeller) under normal use and service. The Kasco Marine, Inc. obligation under this warranty is limited to replacing or repairing free of charge any defective part within two (2) years from the date of shipment. Customer shall pay shipping charges for returning the unit to Kasco or an Authorized Repair Center.

THIS WARRANTY IS IN LIEU OF ANY OTHER WARRANTIES, EXPRESSED OR IMPLIED, AND ANY OTHER OBLIGATION OR LIABILITY WHATEVER ON THE PART OF KASCO MARINE, INC. AND IN NO EVENT SHALL KASCO MARINE, INC. BE LIABLE FOR ANY SPECIAL OR CONSEQUENTIAL DAMAGES.

Warranty is void if:

The Fountain is not maintained properly according to the Maintenance Recommendations supplied in this Owners Manual.

The Fountain is returned for repair without the power cord or if the unit, control box, or power cord are altered in any way from original shipment. Cuts in the power cord are not covered under warranty. Fountain must be connected to the supplied GFI control box to be covered under warranty.

The Fountain is damaged by unauthorized tampering.

Warranty Claim Procedure:

Check the eight-digit serial number printed either on the black cover of the motor or on the blue nameplate and determine the year of manufacture according to the serial number scheme below:

Sample Serial #
70 01 J 1 1725

The first two digits represent the reverse of the last two digits of the year of manufacture.

Example: 70 = 2007 model year.

The third and fourth digit represents the week of the year. (Ex. "01" for first week in Jan.)

The best method for establishing warranty period is through the original **receipt**. Also, register the Fountain online at:
www.kascomarine.com

Once the warranty coverage has been established, the unit may be sent to any Kasco Authorized Repair Center for evaluation and repair. Please call Kasco Marine at 715-262-4488 prior to shipping to receive any updated information and/or Repair Form, then ship to:

Kasco Marine, Inc.
800 Deere Rd.
Prescott, WI 54021
Attn: Repairs

Or call Kasco Marine at 715-262-4488 to locate your nearest Authorized Repair Center. You can also email Kasco at sales@kascomarine.com.

Note: Only complete motor assemblies will be accepted for warranty repair. The power cord and all other components must be returned

with the motor as originally assembled. Any missing parts will be replaced at the customer's expense and, if determined to have caused the failure, could void the entire warranty. Some parts are essential for structural support during shipping and others, such as the power cord, are essential to properly diagnose potential causes of failure. It is not necessary to return the control box with the motor assembly.

Please include the Repair Form received from Kasco Marine or your local distributor with the shipment. If no Repair Form is available, include your name and physical address for return delivery of the repaired unit and a daytime phone number and/or e-mail address for correspondence regarding the warranty claim.

Any expedited shipping method for the return of the unit is at the customer's expense. Kasco Marine will return units repaired under warranty at our expense via ground freight within the continental United States.

Other Repairs:

Most failed equipment can be repaired at substantially lower costs than replacement with new. Please ship according to the instructions in the previous section. Again, it is best to call ahead before sending in a repair.

Kasco Marine does estimates on repairs at the request of the customer. The request for estimate should be included in the letter that accompanies the returned unit and must include a daytime phone number and/or e-mail address. Estimate options are as follows:

We will contact the customer with a total after the unit has been evaluated, but before the work is performed.

We will repair the unit only if repair costs

are under a stated dollar amount. Example: “Please repair if total is under \$150.00 before shipping charges.”

All estimates that are rejected for repair will be destroyed unless otherwise directed by the customer. If the customer would like the unit returned, the unit will be restored as closely as possible to the condition in which it was received and shipped at the customer’s expense for shipping and handling charges.

Billing:

All non-warranty repairs will be returned to the customer and billed C.O.D. unless otherwise directed. Kasco Marine also accepts Visa and MasterCard credit card payments. Kasco Marine will call for credit card information upon completion of the estimate at the customer’s request.

All other warranty and repair inquiries should be directed to Kasco Marine, Inc. at 715-262-4488 or returns@kascomarine.com.

Troubleshooting Tips

Below are some helpful troubleshooting tips. If a problem occurs, please double check the assembly and installation instructions as well as the instructions for the proper control panel. More troubleshooting tips can be found at www.kascomarine.com (Under the Technical Tab)

“ My Fountain trips the ground fault interrupter in the C-25. ”

This is the most common symptom of several possible problems. To correctly diagnose the problem, you will need to collect more information. A Ground Fault Interrupter

(GFI) breaker that trips can indicate an electrical service problem, water contamination in the unit and/or cord, bad breaker, control box problems, motor problems, etc. Try to find out the answers to these questions before you contact Kasco to narrow down the problem.

- How long does it take to trip the breaker?
- Does it always take the same amount of time to trip?
- How many times has it tripped?
- Has there been any electrical problems in the area recently?

“ My Fountain seems to run slowly. ”

This can also be a symptom of several possible problems. There could be an electrical problem where the unit is not getting the proper voltage. This could also indicate a problem with the motor of the unit, which needs to be looked at by an Authorized Repair Center. Check that the unit is receiving the proper voltage, and, if so, contact Kasco for further steps.

“ My Fountain hums, but will not start. When I spin the prop with a stick, it starts up. ”

This indicated a problem with the Starting Capacitor. Each Kasco Fountain is equipped with a Starting Capacitor to get the unit going when it is first plugged in. If it is operating, but not spinning and can be started by spinning the prop with a stick, the Starting capacitor needs to be replaced by an Authorized Repair Center.

“ My Fountain turns itself off and back on without the timer and without tripping the GFI breaker. ”

Each Kasco Fountain has a Thermal Overload built in that will turn the unit off

when it overheats. Once the unit has cooled down, it will start back up. If you are noticing these symptoms, the unit should be unplugged immediately because the Thermal Overload will continue to turn on and off until it burns out and damages the motor. The unit should be unplugged and taken out of the water to find the cause of the problem. The problem could be one of many, such as, low water levels, build-up on the unit to prevent heat dissipation, something inhibiting the free rotation of the shaft, etc. If something is caught in the unit or there is a build-up on the unit, remove the debris and, if caught early enough, the unit should be fine. Contact a Kasco representative before restarting the unit.

“My Fountain flow seems to fluctuate and/or be less than usual.”

This can occur because of a few different reasons. Most of the time, this symptom is caused from unit being clogged with debris. A mat of weeds, many leaves, plastic bags, etc. can clog up the unit and cause it to be starved of water. If the unit does not have the proper amount of water, the flow or pattern will fluctuate up and down and look sporadic. If you are seeing these symptoms, unplug the unit and clean away the debris that is clogging up the screen. Another possibility if these symptoms are noticed, is a chipped or damaged prop that is causing the unit to wobble and not pump properly. When the unit is unplugged, check the prop for damages and replace if damage is found.

“The GFI breaker trips randomly and sporadically. Sometimes it is a few hours of operation, other times it can be days or weeks.”

This is referred to as a Nuisance Trip. This usually occurs where the unit is installed a great distance from the initial electric service on the property where the ground stake is

placed. It is caused by either induced current in the ground wire or a base voltage difference due to soil pH levels. To resolve the problem, contact an electrician and install a local grounding stake. This may eliminate the induced current and any base voltage differences.

1400JF/1400JFL Replacement Parts

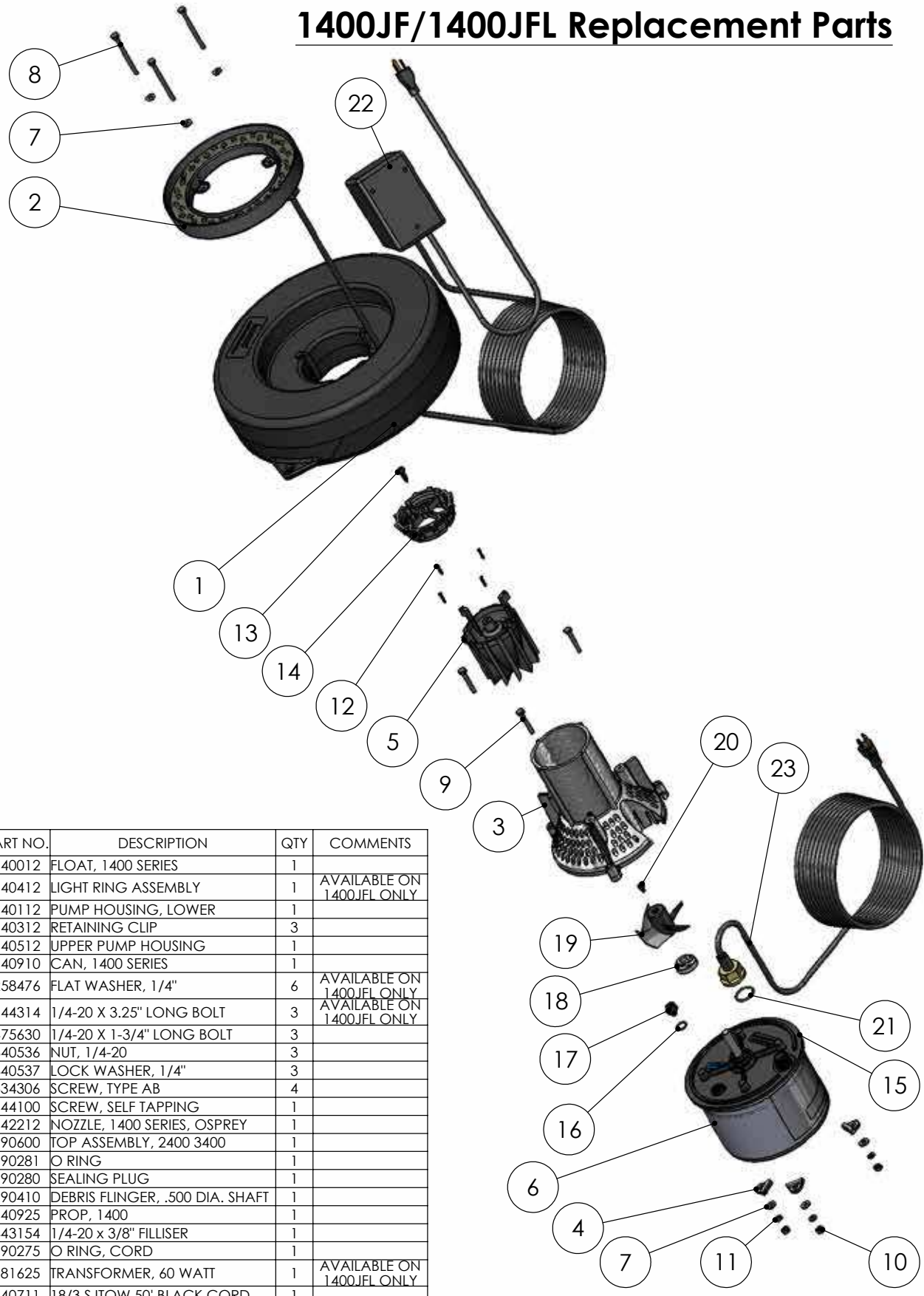

ITEM NO.	PART NO.	DESCRIPTION	QTY	COMMENTS
1	140012	FLOAT, 1400 SERIES	1	
2	140412	LIGHT RING ASSEMBLY	1	AVAILABLE ON 1400JFL ONLY
3	140112	PUMP HOUSING, LOWER	1	
4	140312	RETAINING CLIP	3	
5	140512	UPPER PUMP HOUSING	1	
6	140910	CAN, 1400 SERIES	1	
7	258476	FLAT WASHER, 1/4"	6	AVAILABLE ON 1400JFL ONLY
8	144314	1/4-20 X 3.25" LONG BOLT	3	AVAILABLE ON 1400JFL ONLY
9	475630	1/4-20 X 1-3/4" LONG BOLT	3	AVAILABLE ON 1400JFL ONLY
10	840536	NUT, 1/4-20	3	
11	840537	LOCK WASHER, 1/4"	3	
12	334306	SCREW, TYPE AB	4	
13	144100	SCREW, SELF TAPPING	1	
14	142212	NOZZLE, 1400 SERIES, OSPREY	1	
15	990600	TOP ASSEMBLY, 2400 3400	1	
16	990281	O RING	1	
17	990280	SEALING PLUG	1	
18	990410	DEBRIS FLINGER, .500 DIA. SHAFT	1	
19	140925	PROP, 1400	1	
20	443154	1/4-20 x 3/8" FILLISER	1	
21	990275	O RING, CORD	1	
22	181625	TRANSFORMER, 60 WATT	1	AVAILABLE ON 1400JFL ONLY
23	140711	18/3 SJTOW 50' BLACK CORD	1	



800 Deere Rd.
 Prescott, WI 54021
 Phone: 715-262-4488 - Fax: 715-262-4487
 www.KascoMarine.com Sales@KascoMarine.com

Customer Repair Form

*** Important Reminders ***

- All repairs sent in **MUST** be accompanied by a copy of this completed sheet!
- Routine maintenance consists of keeping the unit clean, keeping the stainless steel can clean, and having the seals and oil replaced every 3 years depending on use.
- Address your Repair to Kasco Marine, Attn: Repairs (or to your Authorized Repair Center).
- Shipping to Kasco or an Authorized Repair Center is paid for by the customer.
- You must include the power cord and cage assembly/fountain housing with each unit sent in for repair to be considered for warranty and for proper repair and shipping protection!
- Do not ship the float and/or control box with the unit for repair, unless otherwise instructed.

Today's Date: _____

Customer Information

Name: _____

Phone Number: _____

Address: _____

Alternate Number: _____

City: _____

Email Address: _____

State: _____

Zip Code: _____

Unit Information:

Model # (Ex. 1400JFL): _____

Serial # (Ex. 7001JL14025): _____

Date Purchased: _____

Purchased From: _____

Earliest Date of Problem: _____

Description of Problem:

Comments:

Registration Information

Please register your fountain online at:

www.kascomarine.com

Also fill in the information below and keep for your records.

Model # (Ex. 1400JF) _____

Serial # (Ex. 7001J141725) _____

Purchase Date: _____

Purchased From: _____

Registration Date: _____



Kasco Marine, Inc.
800 Deere Rd.
Prescott, WI 54021

Phone (715) 262-4488 • Fax (715) 262-4487

www.kascomarine.com • sales@kascomarine.com