



# Owners Manual

## xStream™ Fountain

Model 2400SF

### Contents



Important Safety. . . .	pg2
General Instructions. . . .	pg2
Cord Gauge Chart. . . .	pg3
Unit Specs. . . .	pg3
Parts Included. . . .	pg3
Assembly. . . .	pg4
Nozzle Options and Assembly. . . .	pg5
Installation Instructions. . . .	pg12
Control Panel Installation. . . .	pg12
C-25 Timer Control Instructions. . . .	pg13
Maintenance Recommendations. . . .	pg14
Warranty Policy. . . .	pg15
Troubleshooting Tips. . . .	pg16
Replacement Parts. . . .	pg18
Customer Repair Form. . . .	pg19
Registration Information. . . .	pg20



3020379  
ANSI/UL 778, 5th Ed. 2010  
CAN/CSA C22.2 No. 108-M89  
UL 50, 11th Ed. 1995

Kasco Marine, Inc.  
800 Deere Rd.  
Prescott, WI 54021  
PH (715) 262-4488  
FAX (715) 262-4487  
[www.kascomarine.com](http://www.kascomarine.com)

Rev. 03/08/16

## THANKS

We at Kasco Marine, Inc. would like to both thank and congratulate you on your purchase of the xStream fountain. We appreciate you choosing Kasco and for your purchase. Your decision to purchase Kasco's xStream Fountain will not disappoint you. The fountain will be a great addition to your body of water. It will help improve the water quality by adding much needed oxygen and circulation. It will also enhance the aesthetics of the pond or lake with a beautiful fountain pattern. The lighting package (if purchased) will illuminate your fountain for beauty at night. We thank you for choosing Kasco for your fountain needs and want you to be completely satisfied with your purchase.

## Important Safety

Please read and follow these extremely important safety and handling instructions for your Kasco equipment. Following these instructions will help ensure your safety and the quality performance of your equipment.

- Under NO circumstances should anyone enter the water with the electrical equipment plugged in and/or in operation. All Kasco equipment is ETL approved to UL and CSA standards for safety in water and all fountain models include control panels with GFI protection. However, it is NEVER recommended to enter the water with the equipment in operation.
- Caution should be used when dealing with any electrical equipment with moving parts.
- NEVER run the unit out of water. It will damage the seals and create a dangerous situation for the operator.
- Extreme caution should be used around water, especially cold water, such as in Spring, Fall, and Winter, which poses a hazard in and of itself.
- NEVER lift or drag the fountain by the power or light cord. If you need to pull the unit to the side of the pond, use the anchoring ropes.
- Do not use waders in deep ponds/lakes or ponds/lakes with drop-offs, drastic slopes, or soft bottom material.
- Do not use boats that tip easily for fountain installation, such as a canoe, and follow all boating safety rules and regulations, including wearing a PFD. (Personal Flotation Device)
- The fountain is supplied with an internal grounding conductor and a grounding-type attachment plug. To reduce the risk of electrical shock, be certain that the fountain is plugged into the C-25 Control Box (120V) supplied by Kasco and that the C-25 is plugged into a properly grounded, grounding type receptacle. The GFCI breakers should be tested upon each installation and every month thereafter to ensure proper operation.

## General Instructions

### INSPECT THE SHIPMENT

Immediately inspect your Kasco Fountain shipment for any visible damages. Also cross reference the parts supplied with the Parts Included sheet to check for shortages. Shortages should be reported immediately to your Kasco Marine distributor or representative and damages reported to your carrier and Kasco Marine.

### CAUTION

**WARNING:** Under NO circumstances should anyone enter the water with the unit in operation. Always operate the unit in the water and keep people and objects clear of the propeller. Do not lift or pull the unit by the electrical cord. Always use extreme caution around electrical equipment and water situations.

### ASSEMBLY & INSTALLATION

Please see the proper Assembly and Installation Instructions enclosed in this manual. Each is specific for your model and size of Fountain. Note: Use a nylon tie on power cords to the float for strain relief. If you have a light kit, make sure that the unit cord is tied to one side of the float and the light cord to the other for balance. Note: It is extremely important to test the GFI breaker in the control panel upon each installation/reinstallation of the unit to ensure proper functioning.

### WARRANTY

Kasco Fountains are the result of over 40 years of design and engineering. Kasco products are built to withstand the toughest conditions. Kasco Marine backs each 2400SF model Fountain with a 2 Year Warranty. This warranty covers any and all manufacturers defects within 2 year from the date of purchase (See Warranty & Return Policy).

### USE AND OPERATION

Kasco Fountains are designed and engineered for continuous duty, such as on fish farms or other aquaculture applications, or on-demand use, as needed in a recreational water feature.

During flotation operation, the water is pulled from 360° around the unit and from below the unit. The water is pulled upward and thrust through the flotation collar into the air.

Your Kasco Marine Fountain is ready for immediate use (after installation). The motor and ball bearings are submerged in oil and no further lubrication is needed. Make sure to keep the motor housing clean from hard water deposits and/or algae. (See Maintenance Recommendations.)

It is extremely important that proper and sufficient voltage (120V) is supplied to the Fountain motor. Each 120V Fountain is supplied with a UL and CSA approved C-25 GFI Protected Control Box. The Fountain is to be plugged into the C-25 outlet labeled "UNIT" and the C-25 plugged into a properly grounded receptacle (See C-25 Instructions). It is extremely important to test the GFI breaker in the control panel upon each installation and reinstallation and every month thereafter to ensure proper operation.

Kasco Fountains are lightweight, energy efficient, and easy to install and operate. We strive to produce products that exceed customer expectations. We hope you enjoy your Kasco Fountain.

### Cord Gauge Chart

Length	Gauge
50'	16
100'	14
150'	12
200'	12

### Unit Specs

Model	Voltage	Amps	Lock rotor amps	Control box connection	Fountain connection
2400SF	110-120	6.6 - 7.3	18	C-25 plug in	Plug into C-25

### Parts Included

- 2400SF Aerating Fountain (Unit with cord or unit with Disconnect) (1)
- Float (with three 50' mooring ropes attached) (1)
- 1/4" x 3 1/4" screw (3)
- Debris Screen Sections (3)
- #8 screw (6)
- #8 lock washer (6)
- #8 flat washer (12)
- #8 nut (6)
- 1/4" x 1 3/8" screw (3)
- 1/4" lock washer (6)
- 1/4" flat washer (9)
- 1/4" nut (6)
- Flow straightener (1)
- #6 x 3/4" screws (4)
- O-ring (1)
- Nozzle (1)
- small plugs for nozzle (20) (not pictured)
- Large plug for nozzle center hole (2) (not pictured)
- #6 x 1/2" screw (4)

20. #6 flat washer (4)

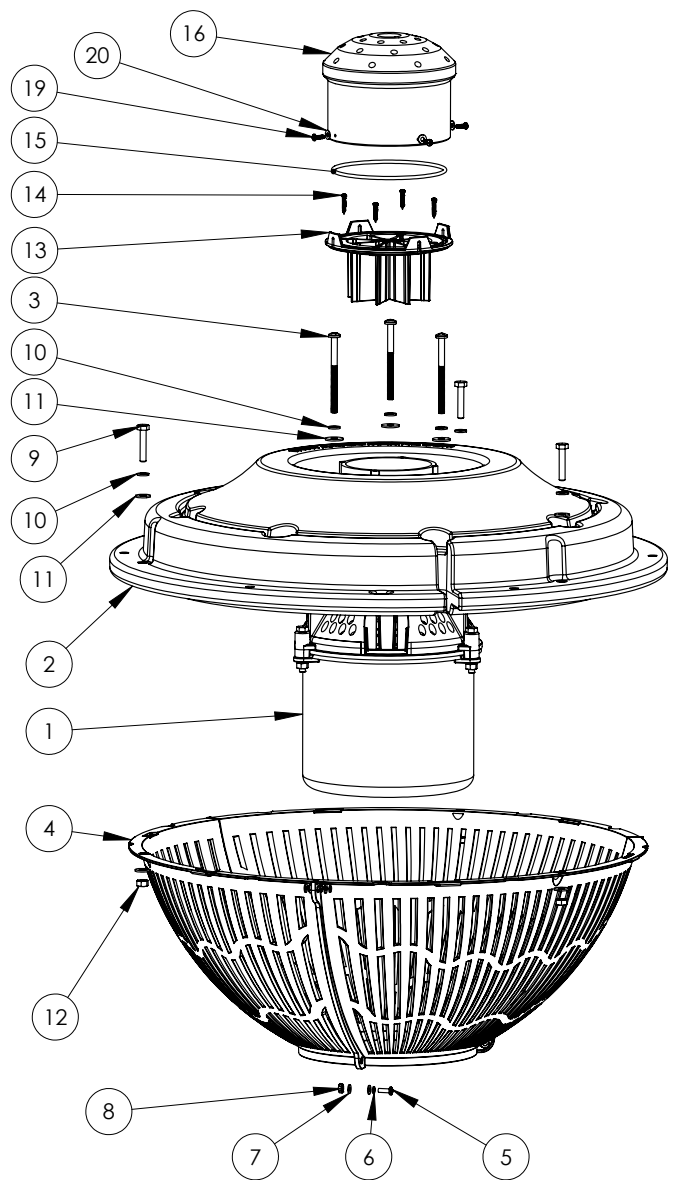

Also Included:

- Cord in separate box (1) (150' or 200' cords only)
- Control Box (C-25) (1) (Not Pictured)

### TOOLS & SUPPLIES NEEDED

- Anchors or stakes for installing unit (2)
- # 2 Phillips head screw driver
- 120V Electrical Supply near pond on a post with room for mounting the C-25
- Three 12" pieces of 1" galvanized pipe or weighted tubing for weighting ropes (optional)
- #10 x 1" long or longer screw(s) for mounting the C-25 (3)
- 7/16" Socket and Ratchet (for 1/4" fasteners)
- 7/16" Wrench (for 1/4" fasteners)
- 11/32" wrench (for #8 fasteners)

## Assembly

1. Make sure you have all the parts needed. If any shortages are found, contact your Kasco representative immediately.

2. Place float on motor housing. The power cord notch on the float should line up with the cord. See diagram below of bottom side of float. The 3 bolt holes in the float should line up with bolt receptacles on unit.

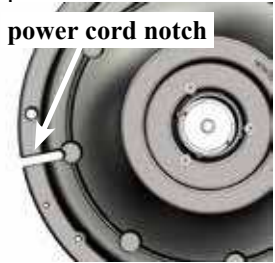

3. Use one of the 1/4"-20 x 3-1/4" Phillips Pan Head Screws, one 1/4" split washer, and a 1/4" Flat Washer to secure the float. Make sure the split washer goes between the bolt head and the flat washer. Insert screw with washers through bolt hole in float. Tighten until snug with a Phillips Head screw driver and repeat for 2 remaining screws.



4. Set motor housing and float upside down on a flat surface.



5. Bring the 3 bottom screen sections together.



6. Secure the 3 sections of the screen together in 6 places using #8 screw, #8 lock washer, two #8 flat washers, and #8 nut. **Do not overtighten.** Alternately, use cable ties instead of hardware for a quicker assembly of the screen.

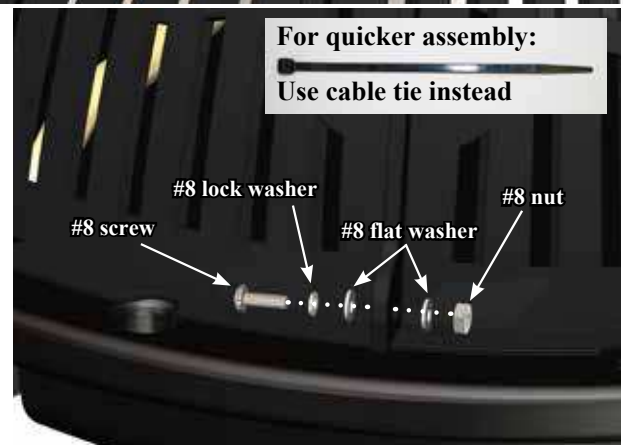
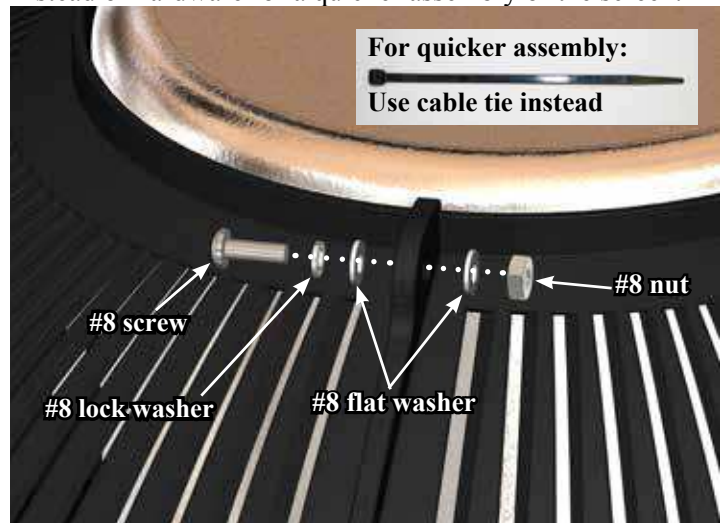

7. Make sure the cord is coming out of the notch in the float before attaching the screen to the float.



8. Align the screen to the float using the picture to guide you. Attach the screen to the float in 3 places using 1/4" x 1 3/8" bolt, 1/4" lock washer, two 1/4" flat washers, and 1/4" nut. **Do not overtighten.**

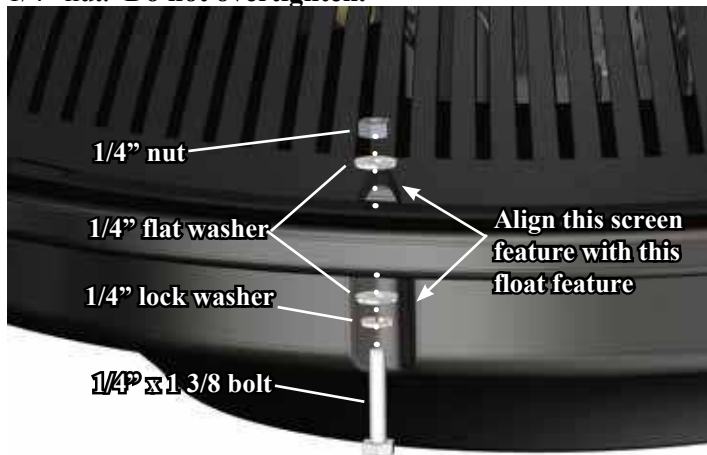

9. Flip the unit back over so that the stainless steel can is resting on a flat surface. Use the Nylon Cable Tie included to secure the power cord to a molded hole in the float to prevent cord damage if there is no strain relief on the cord. If you purchased the 150' or 200' cord, the cord contains a metal strain relief, you can use the chain connector and attach it to one of the rope loops by the float. If installing a new Quick Disconnect, refer to Quick Disconnect Instructions included in the cord box. The unit is now ready for nozzle choice and assembly.

### Nozzle Options and Assembly

V shaped pattern:

**Requires no flow straightener or nozzle assembly.** Store those parts in a safe place for future use. This V pattern provides the highest flow rate and aeration. Pattern size is 6' High by 13' diameter.



All other nozzle options require the following assembly:

1. Place the flow straightener in the fountain tube making sure it rests securely against the tube and the holes line up. Attach the straightener using four #6 x 3/4" screws.

**IMPORTANT: Make sure there is no gap between the tube and flow straightener and that the screws are tightened down securely. Loose screws or a gap can lead to reduced performance.**

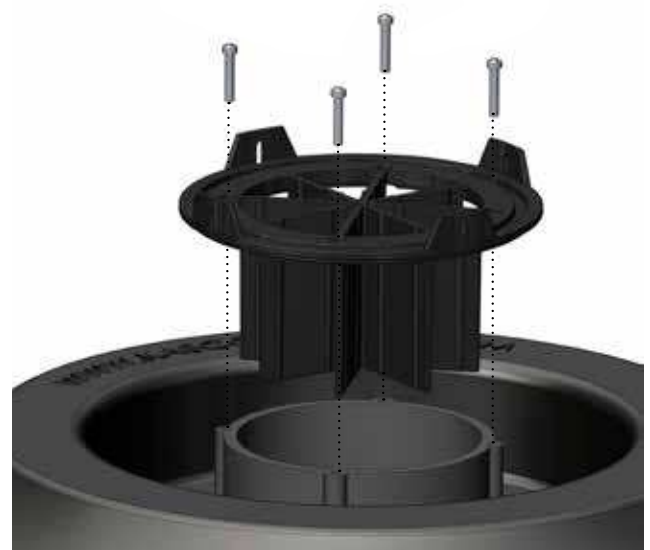

**Make sure there is no gap**

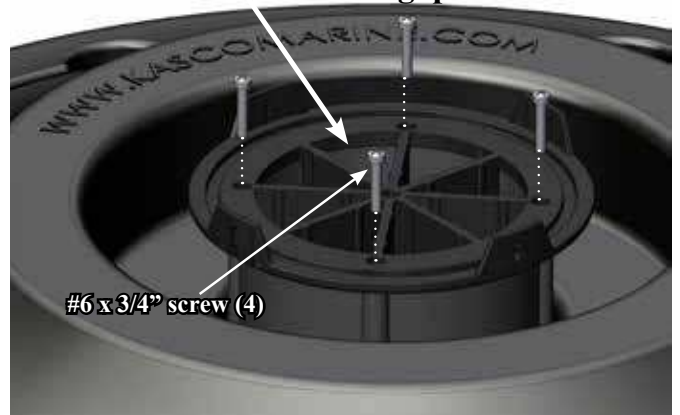

2. Place the oring in the oring groove on the flow straightener.



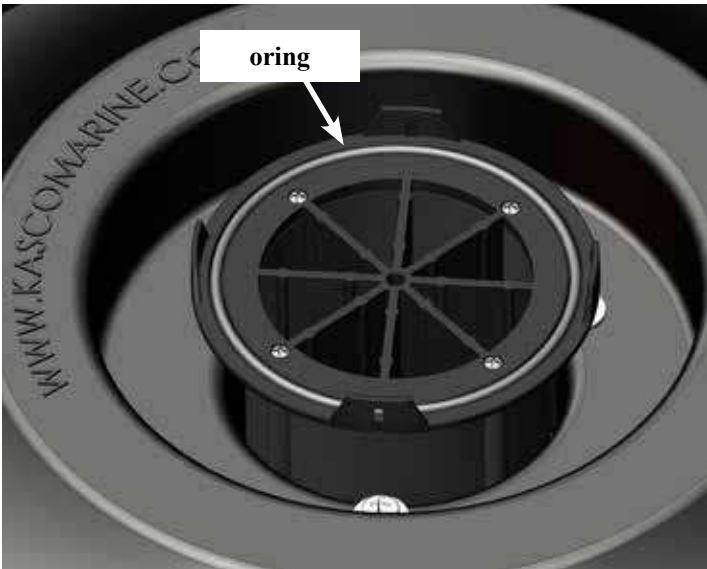

**Important:**

Push in black plugs on the **inside** of the nozzle only.

Plugs on Inside











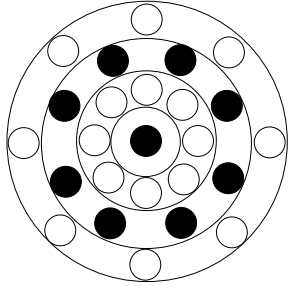

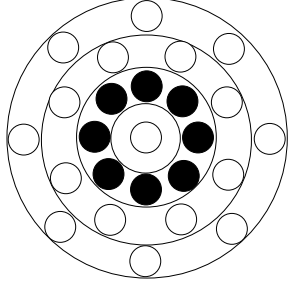

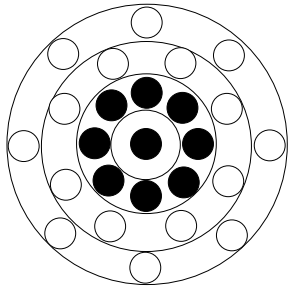
3. Prepare the nozzle before installing using the nozzle choice chart. Different patterns are created by plugging or removing plugs from the inside holes in the nozzle. After using the chart and nozzle pictures to choose a pattern, push plugs into the holes shown with black circles on the chart. The number of possible patterns are not all shown on the following chart.

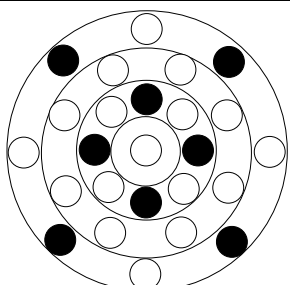

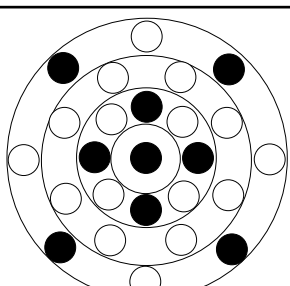

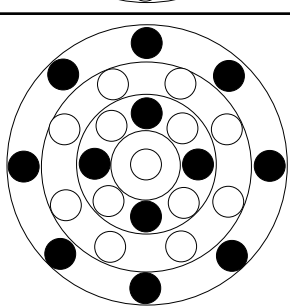





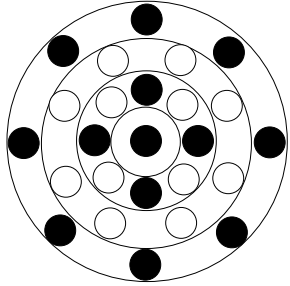

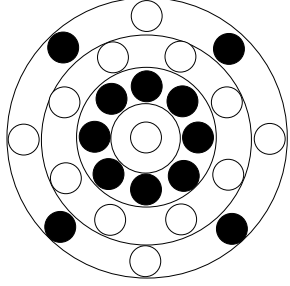
Nozzle Option Chart:

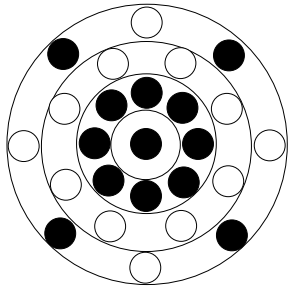

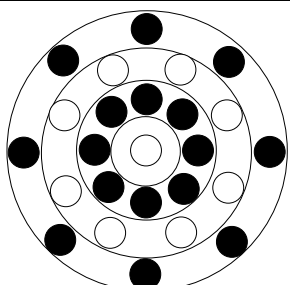

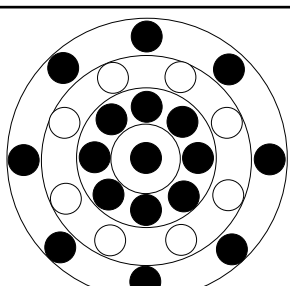

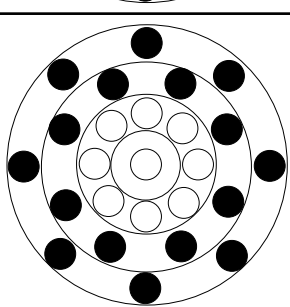



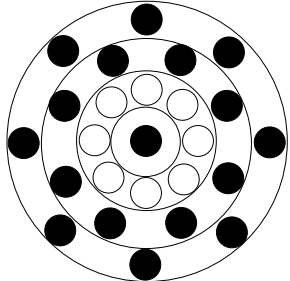

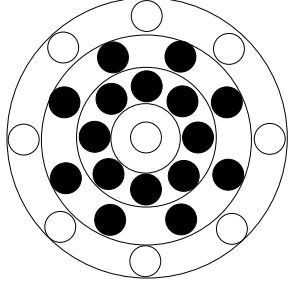
Pattern #	Height (ft)	Width (ft)	Plug diagram (black circles show plug locations)	Picture
1	6	18		
2	4.5	18		
3	6.5	18.5		

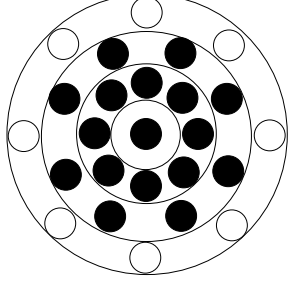
Pattern #	Height (ft)	Width (ft)	Plug diagram (black circles show plug locations)	Picture
4	5	18.5		
5	6.5	18.5		
6	5	18.5		
7	7	17		
8	5.5	17		
9	7	21		

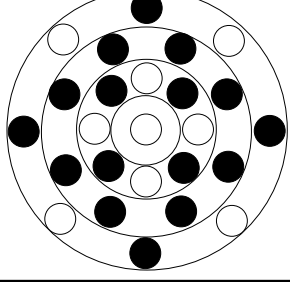

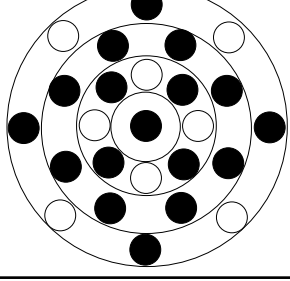

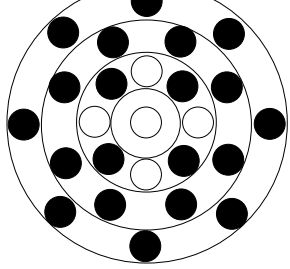





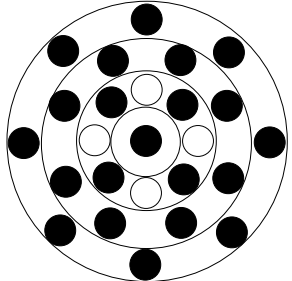

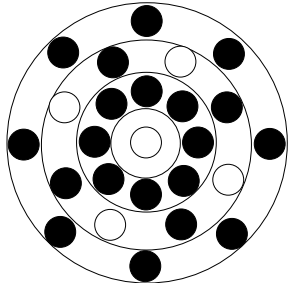
Pattern #	Height (ft)	Width (ft)	Plug diagram (black circles show plug locations)	Picture
10	5.5	21		
11	7	21		
12	4.5	21		
13	7	21		
14	5.5	21		
15	7.5	20		

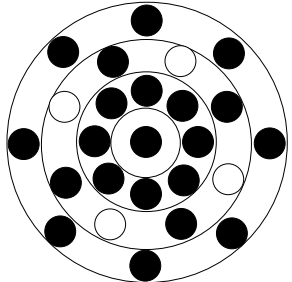

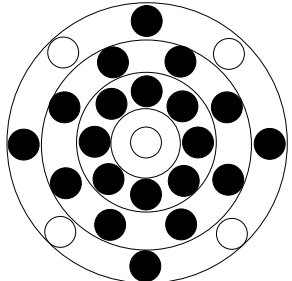
Pattern #	Height (ft)	Width (ft)	Plug diagram (black circles show plug locations)	Picture
16	6	20		
17	7.5	23		
18	5.5	23		
19	8	21		
20	5.5	21		
21	8	13		

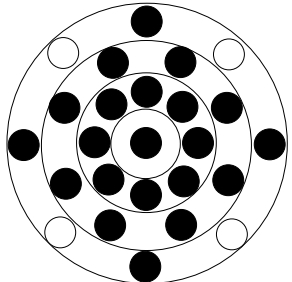
Pattern #	Height (ft)	Width (ft)	Plug diagram (black circles show plug locations)	Picture
22	6.5	13		
23	8	25		
24	4	25		
25	8	25		
26	6.5	25		
27	8.5	13		

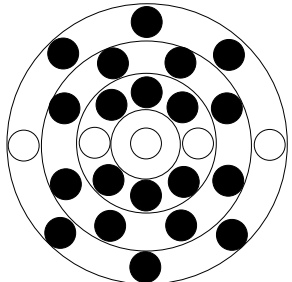

Pattern #	Height (ft)	Width (ft)	Plug diagram (black circles show plug locations)	Picture
28	6.5	13		
29	8.5	22		
30	5	22		
31	8.5	24		
32	4	24		
33	8.5	24		

NOTE: Pattern sizes listed are approximate. Variations in voltage caused by regional electrical differences or voltage drop due to long power cords may result in reduced pattern sizes.

4. After the nozzle is prepared, attach it to the flow straightener in 4 places using #6 x 1/2" screws and washers.



5. The unit is now ready to be installed.

### Installation Instructions

Use the ropes to position the Fountain in the desired location in the pond/lake. Anchor the ropes or secure them to the shoreline so the ropes are free of slack, but not tight. To prevent twisting of the unit due to torque, you should place the anchor at least 3 feet from the float for each foot of depth (Ex. A 6 foot deep pond would require an anchor 18 feet horizontally from the float.)

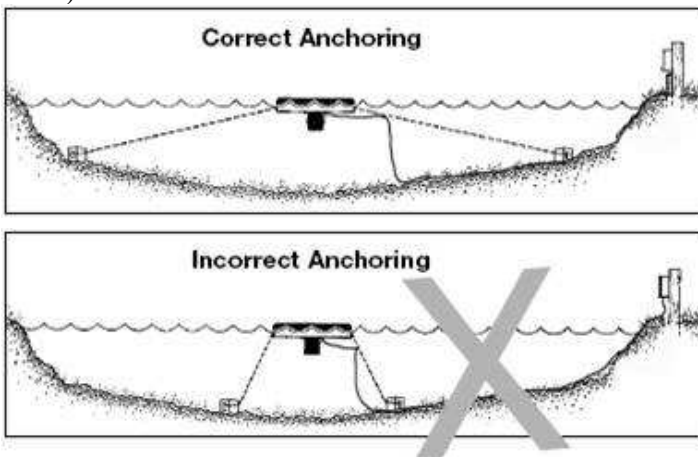

### ALTERNATE INSTALLATION

In ponds where the water level fluctuates significantly, you may need to suspend a small weight (12" of 1" galvanize pipe works well) at the mid-point of the rope to take up any slack as the water level drops. The weight should be light enough so the Fountain can rise as the water level rises. This can also help hide ropes

by sinking them further below the surface.

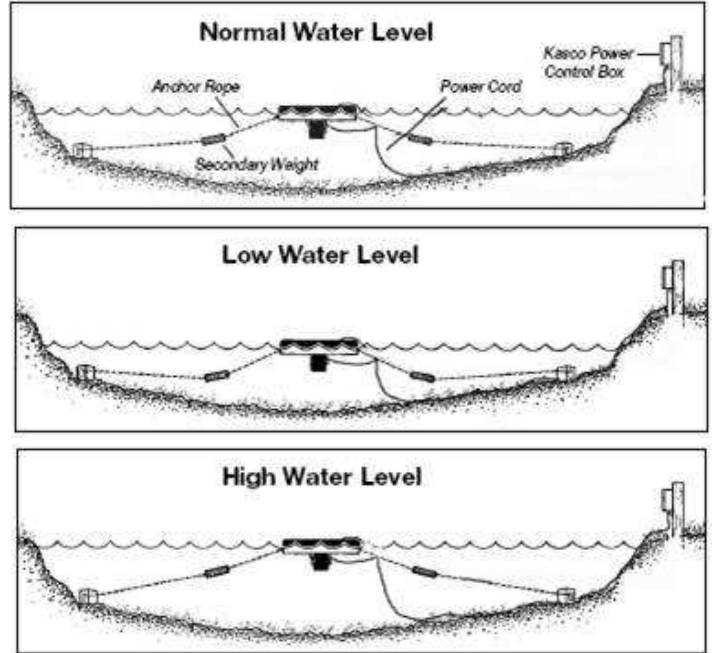

### Control Panel Installation

1. Inspect the panel for any damage and any components that may have loosened during shipping.

Control panel must be installed a minimum of 5ft (3m in Canada) from the inside wall of the pond, unless separated from the body of water by a fence wall, or other permanent barrier that will make the unit inaccessible to persons in the water.

Install the control panel to a post structure, side of a building, or other reliable means. This structure must support the panel and prevent movement/flexing of the panel. Use #10 x 1" or longer screws in the mounting points of the control panel to secure to the post structure. NOTE: The control panel must be hung upright in order to be waterproof. It is also advised to mount the panel out of direct sunlight if possible. Mounting the panel in a North direction will prevent heat buildup inside the panel. Also, mount the panel above the potential flood plain to prevent water entry during a possible flood event.

2. Set Timer in the control panel to desired ON and OFF times per the Instructions for each specific timer.

3. **Follow all local and national electrical codes for this installation and Consult a qualified electrician or service person if needed.**

Plug the aerator cord into the C-25 outlet labeled "UNIT". If lights are included, plug the cord into the C-25 outlet labeled "LIGHT". Now you are ready to plug the C-25



into the 120V power supply on the post and ENJOY YOUR NEW KASCO AERATOR!

**4. Test the GFCI with the test button now and every 30 days.**

Any unauthorized modifications to this control panel will void the UL listing and the Kasco warranty.

**C-25 Timer Control Instructions**

Portable Timer with Ground Fault Interrupter

**IMPORTANT**

This portable timer is designed for CONTROLLING the connected equipment only. Unplug timer before servicing the unit or the equipment it controls. For maximum protection against electrical shock hazard, perform test procedure on G.F.C.I. at least once a month. Mount at least 5 ft. from open water.

**G.F.C.I. TEST PROCEDURE**

The G.F.C.I. should be checked every month to make sure that it is operating properly. Just follow the simple instructions below. It is recommended to maintain a maintenance diary of your monthly safety check.

1. Push TEST button, RESET button should pop out from inner surface. This should result in power being OFF at the outlet protected by the G.F.C.I. Verify by plugging a test lamp into the outlet. Be sure the timer is in the ON position.
2. If the G.F.C.I. tests okay, restore power by pushing the RESET button back in. THE RESET BUTTON MUST BE PUSHED FIRMLY AND FULLY INTO PLACE UNTIL IT LOCKS AND RE-MAINS DEPRESSED AFTER PRESSURE HAS BEEN REMOVED.

**DANGER: IF RESET BUTTON DOES NOT POP OUT, IF TEST LAMP REMAINS LIT WHEN RESET BUTTON DOES POP OUT, OR IF THE G.F.C.I. FAILS TO RESET PROPERLY, DO NOT USE TIMER! CONTACT A QUALIFIED SERVICE TECHNICIAN!**

Failure to use the C-25 with Kasco Fountains will void the warranty and cause the Fountain to not be listed to UL and CSA standards via ETL.

**UNDER NO CIRCUMSTANCES SHOULD ANYONE ENTER THE WATER WHEN A UNIT IS IN OPERATION!**

**TIMER-OPERATION INSTRUCTIONS**

C-25 Control Box will turn the aerator/fountain ON & OFF with the TIMER. Kasco lights will turn ON with the PHOTO EYE and OFF with TIMER. C-25 Control Box is to be used with Kasco Approved Lights ONLY!

- See Control panel label for instructions to set the timer
- Plug aerator/fountain cord into the RIGHT hand outlet (labeled UNIT).
- Plug transformer light cord into LEFT hand outlet (labeled LIGHT).

## Maintenance Recommendations

**\*\* Under No Circumstances should anyone enter the water while a fountain is operating. \*\***

**\*\* Please keep the original box for maintenance shipping. \*\***

The following maintenance procedures can be utilized to ensure many years of quality performance from your Kasco Fountain and reduce the need for more costly repair work.

**PROPER INSTALLATION:** Proper installation of Kasco equipment will include a power source with ground fault interruption (GFI). For Fountain models, the C-25 control (120V) included with the unit has built-in ground fault interruption that is sufficient. Ground fault interrupters are a safety feature that can also alert you to electrical leaks in the equipment. It is extremely important to test the GFI upon installation, each reinstallation, and monthly thereafter to ensure proper operation. If you have repeat, consistent trips on your ground fault, the equipment should be disconnected and removed from the water. The power cord should be inspected for damage and you should call Kasco Marine at 715-262-4488 for further instructions or email Kasco at [returns@kascomarine.com](mailto:returns@kascomarine.com).

**OBSERVATION:** Operating equipment should be observed on a regular basis (daily, if possible) for any reduction or variation in performance. If a change in performance is observed, the equipment should be disconnected from power and inspected for any material that may have clogged the system or wrapped around the shaft of the motor, especially plastic bags and fishing line. Even though Kasco Aerators and Fountains are among the most clog-resistant on the market, it is impossible to protect against all items that can clog equipment and still maintain a flow of water. These materials can be very damaging to the equipment under continued operation and must be removed as soon as possible. **ALWAYS UNPLUG THE UNIT BEFORE ATTEMPTING TO REMOVE CLOGS.**

**WINTER STORAGE:** In regions where there is significant freezing in the wintertime, the fountains should be removed from the water to protect them from the expansion pressure of the ice. In many areas, fountains will keep some amount of ice open through

the winter. However, when the water is thrust into the air, it is exposed to the colder air temperatures longer and can actually make ice thicker on the pond/lake. Storage over winter is best in a location that is out of the sun and cool, but above 32°F. It is not necessary to store Kasco motors upside down. All internal seals are fully lubricated while stored in an upright position.

**CLEANING:** Fountains should be removed from the water at least once per year (at the end of the season in cold climates) to clean the exterior of the system, especially the stainless steel motor housing (can). The motor housing is the surface that dissipates heat into the water and any algae, calcium, etc. build-up will become an insulator that blocks heat transfer. In warmer regions it is recommended that the motor is removed and cleaned at least two to three times per year depending on conditions. In most cases a power washer will be sufficient if the unit and algae are still wet.

**SEAL AND OIL REPLACEMENT:** This is a sealed motor assembly and seals will wear out over time (similar to brake pads on a car). Replacement of the seals and a change of oil after three years may add longevity to the operation of the motor, saving you the cost of more expensive repairs. In warmer climates where the fountain runs most or all of the year, it is a good idea to replace seals more regularly than you would need to in colder climates where the unit is removed from the water for several months.

**ZINC ANODE:** A Sacrificial Zinc Anode is supplied on the shaft for protection of the equipment from corrosion and electrolysis. The zinc anode should be updated (replaced) if reduced to half the original size or if white in color. Corrosion from electrolysis is more commonly associated with saltwater or brackish water, but as a matter of precaution, it is important to periodically check the zinc anode in all installations (at least every two to three months).

Seal replacement and all other repair services should be performed by Kasco Marine or a Kasco trained Authorized Repair Center. Any alterations or changes made to Kasco units by an unauthorized source will void the warranty. This includes tampering with the unit, power cord, and/or control box. Please contact Kasco Marine, Inc. at 715-262-4488 for your nearest Authorized Repair Center.

## Warranty Policy

Warranty Period:

Model: 2400SF - 2 years

Kasco® Marine, Inc. warrants this Fountain to be free from defects in material or workmanship (except for the ropes, power cord, and propeller) under normal use and service. The Kasco Marine, Inc. obligation under this warranty is limited to replacing or repairing free of charge any defective part within the warranty period from the date of shipment. Customer shall pay shipping charges for returning the unit to Kasco or an Authorized Repair Center.

THIS WARRANTY IS IN LIEU OF ANY OTHER WARRANTIES, EXPRESSED OR IMPLIED, AND ANY OTHER OBLIGATION OR LIABILITY WHATEVER ON THE PART OF KASCO MARINE, INC. AND IN NO EVENT SHALL KASCO MARINE, INC. BE LIABLE FOR ANY SPECIAL OR CONSEQUENTIAL DAMAGES.

Warranty is void if:

- The Fountain is not maintained properly according to the Maintenance Recommendations supplied in this Owners Manual.
- The Fountain is returned for repair without the power cord or if the unit, control box, or power cord are altered in any way from original shipment. Cuts in the power cord are not covered under warranty.
- The Fountain is damaged by unauthorized tampering.
- The Sacrificial Zinc Anode around the propeller shaft shows significant deterioration. (The Anode must be inspected periodically and replaced if necessary.)

Warranty Claim Procedure:

Check the eleven-digit serial number printed either on the black cover of the motor or on the blue nameplate and determine the year of manufacture according to the serial number scheme below:

Sample Serial #

21 01 S 24 1725

The first two digits represent the reverse of the last two digits of the year of manufacture.

Example: 21 = 2012 model year.

The third and fourth digits represent the week of the year. (Ex. "01" for 1st week in Jan.) model.

The best method for establishing warranty period is by keeping your original receipt. Also register the Fountain online at:

[www.kascomarine.com](http://www.kascomarine.com)

Kasco Marine will have a record of the purchase and will be able to determine whether or not the unit still carries warranty coverage.

Once the warranty coverage has been established, the unit may be sent to any Kasco Authorized Repair Center for evaluation and repair. Please call Kasco Marine at 715-262-4488 prior to shipping.

Kasco Marine, Inc.  
800 Deere Rd.  
Prescott, WI 54021  
Attn: Repairs

Or call Kasco Marine at 715-262-4488 to locate your nearest Authorized Repair Center. You can also email Kasco at [returns@kascomarine.com](mailto:returns@kascomarine.com)

Note: Only complete motor assemblies will be accepted for warranty repair. The power cord and all other components must be returned with the motor as originally assembled. Any missing parts will be replaced at the customer's expense and, if determined to have caused the failure, could void the entire warranty. Some parts are essential for structural support during shipping and others, such as the power cord, are essential to properly diagnose potential causes of failure. It is not necessary to return the control box or float with the motor assembly.

Please include the Repair Form received from Kasco Marine or your local distributor with the shipment. If no Repair Form is available, include your name and physical address for return delivery of the repaired unit and a daytime phone number and/or e-mail address for correspondence regarding the warranty claim.

Any expedited shipping method for the return of the unit is at the customer's expense. Kasco Marine will return units repaired under warranty at our expense via ground freight within the continental United States.

### Other Repairs:

Most failed equipment can be repaired at substantially lower costs than replacement with new. Please ship according to the instructions in the previous section. Again, it is best to call ahead for a Return Authorization Number and/or Repair Form so we know the repair is coming.

Kasco Marine does estimates on repairs at the request of the customer. The request for estimate should be included in the letter that accompanies the returned unit and must include a daytime phone number and/or e-mail address. Estimate options are as follows:

We will contact the customer with a total after the unit has been evaluated, but before the work is performed. We will repair the unit only if repair costs are under a stated dollar amount. Example: "Please repair if total is under \$150.00 before shipping charges."

All estimates that are rejected for repair will be destroyed unless otherwise directed by the customer. If the customer would like the unit returned, the unit will be restored as closely as possible to the condition in which it was received and shipped at the customer's expense for shipping and handling charges.

### Billing:

All non-warranty repairs will be returned to the customer prepaid with Visa or Mastercard or shipped C.O.D. with C.O.D. charges unless otherwise directed. Kasco Marine will call for credit card information upon completion of the repair.

All other warranty and repair inquiries should be directed to Kasco Marine, Inc. at 715-262-4488 or [returns@kascomarine.com](mailto:returns@kascomarine.com)

## Troubleshooting Tips

Below are some helpful troubleshooting tips. If a problem occurs, please double check the assembly and installation instructions as well as the instructions for the proper control panel. More troubleshooting tips can be found at [www.kascomarine.com](http://www.kascomarine.com) (under the technical tab)

*"My Fountain flow seems to fluctuate and/or be less than usual."*

If the nozzle is being used, make sure the flow straightener is tightened securely to the fountain housing. A gap between the flow straightener and housing will result in a loss of pressure and the performance will be reduced. Also check to see if the oring is installed correctly between the flow straightener and nozzle.

This symptom is also caused from unit being clogged with debris. A mat of weeds, many leaves, plastic bags, etc. can clog up the unit and cause it to be starved of water. If the unit does not have the proper amount of water, the flow or pattern will fluctuate up and down and look sporadic. If you are seeing these symptoms, unplug the unit and clean away the debris that is clogging up the screen either screen. Another possibility if these symptoms are noticed, is a chipped or damaged prop that is causing the unit to wobble and not pump properly. When the unit is unplugged, check the prop for damages and replace if damage is found.

*"My Fountain trips the ground fault interrupter in the C-25."*

This is the most common symptom of several possible problems. To correctly diagnose the problem, you will need to collect more information. A Ground Fault Interrupter (GFI) breaker that trips can indicate an electrical service problem, water contamination in the unit and/or cord, bad breaker, control box problems, motor problems, etc. Try to find out the answers to these questions before you contact Kasco to narrow down the problem.

- How long does it take to trip the breaker?
- Does it always take the same amount of time to trip?
- How many times has it tripped?
- Has there been any electrical problems in the area recently?

*"My Fountain seems to run slowly."*

This can also be a symptom of several possible problems. There could be an electrical problem where the unit is not getting the proper voltage. This could also indicate a problem with the motor of the unit, which needs to be looked at by an Authorized Repair Center. Check that the unit is receiving the proper voltage, and, if so, contact Kasco for further steps.



*“My Fountain hums, but will not start. When I spin the prop with a stick, it starts up.”*

This indicated a problem with the Starting Capacitor. Each Kasco Fountain is equipped with a Starting Capacitor to get the unit going when it is first plugged in. If it is operating, but not spinning and can be started by spinning the prop with a stick, the Starting capacitor needs to be replaced by an Authorized Repair Center.

*“My Fountain turns itself off and back on without the timer and without tripping the GFI breaker.”*

Each Kasco Fountain has a Thermal Overload built in that will turn the unit off when it overheats. Once the unit has cooled down, it will start back up. If you are noticing these symptoms, the unit should be unplugged immediately because the Thermal Overload will continue to turn on and off until it burns out and damages the motor. The unit should be unplugged and taken out of the water to find the cause of the problem. The problem could be one of many, such as, low water levels, build-up on the unit to prevent heat dissipation, something inhibiting the free rotation of the shaft, etc. If something is caught in the unit or there is a build-up of algae, calcium or organic matter on the unit, remove the debris and, if caught early enough, the unit should be fine. Contact a Kasco representative before restarting the unit.

*“The GFI breaker trips randomly and sporadically. Sometimes it is a few hours of operation, other times it can be days or weeks.”*

This is referred to as a Nuisance Trip. This usually occurs where the unit is installed a great distance from the initial electric service on the property where the ground stake is placed. It is caused by either induced current in the ground wire or a base voltage difference due to soil pH levels. To resolve the problem, contact an electrician and install a local grounding stake. This may eliminate the induced current and any base voltage differences. This problem can also be caused by a bad breaker or receptacle or having unbalanced incoming voltage lines.

# 2400SF REPLACEMENT PARTS

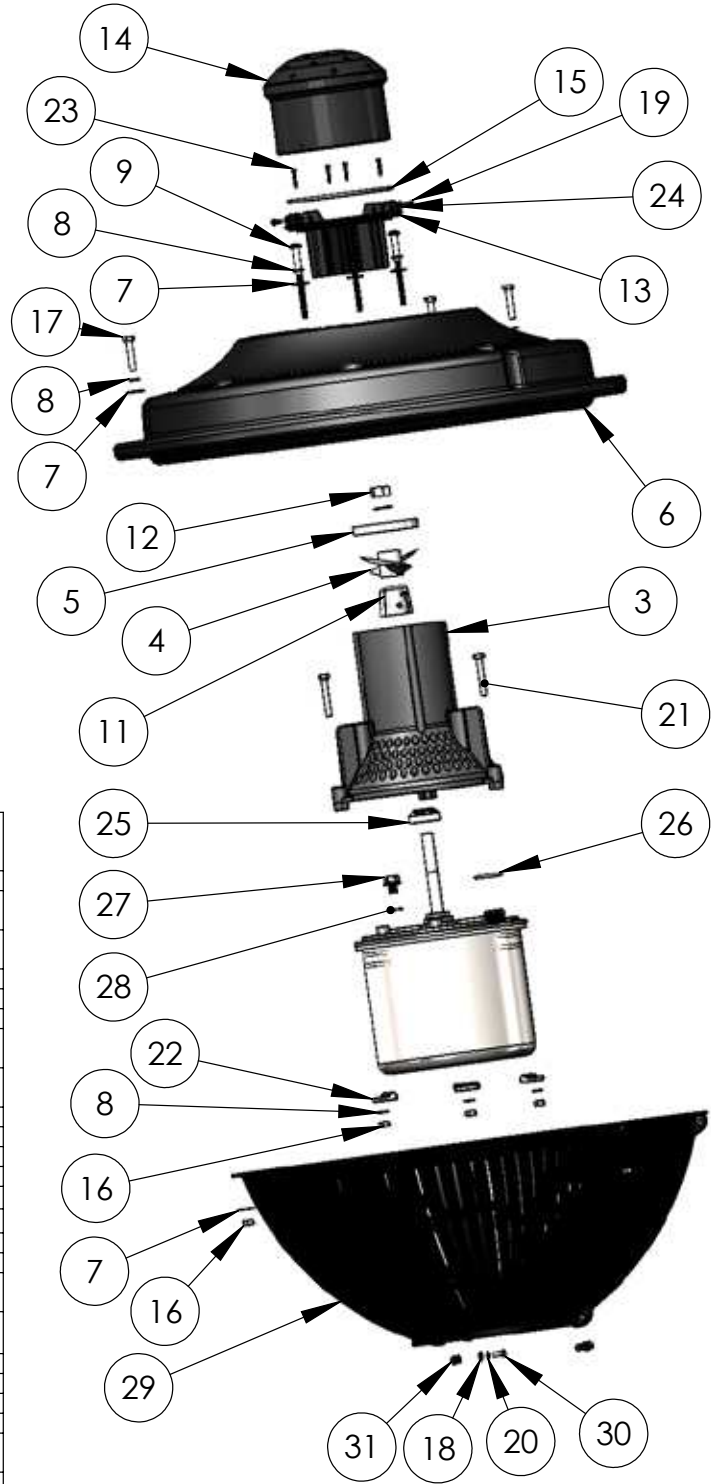

ITEM NO.	PART NUMBER	DESCRIPTION	QTY.	TORQUE VALUES
3	140112	PUMP HOUSING, LOWER	1	
4	361110	PROP, 1/2HP, HIGH SPEED FOUNTAIN	1	HAND TIGHT
5	361115	DISC, 1/2HP, HIGH SPEED FOUNTAIN	1	
6	361500	FLOAT, 1/2 HP	1	
7	251300	FLAT WASHER, 1/4"	9	
8	840537	LOCK WASHER, 1/4"	9	
9	251200	1/4-20 X 3-1/4 PHIL PAN HEAD	3	
10	241024	WASHER, 1/2IN, BRONZE, INTERNAL TOOTH LOCK	1	
11	243475	ZINC ASSEMBLY	1	20 IN LBS
12	462237	1/2 - 20 waxed nut SS	1	
13	361310	FLOW STRAIGHTENER	1	
14	361320	NOZZLE, 1/2 HP FOUNTAIN	1	
15	361313	Oring, 1/2 hp nozzle	1	
16	840536	NUT, 1/4-20	6	50 IN LBS
17	584692	1/4-20 X 1-3/8" BOLT	3	
18	361543	#8 flat washer	12	
19	820405	SCREW, #6x1/2 IN, PH PHIL, ULTRA SS	4	
20	771033	Washer, #8 split lock, black oxide	6	
21	475630	1/4-20 X 1-3/4" LONG BOLT	3	
22	140312	RETAINING CLIP	3	
23	334306	SCREW, TYPE AB	4	
24	334300	#6 washer	4	
25	990410	DEBRIS FLINGER, .500 DIA. SHAFT	1	
26	990275	O RING, CORD	1	
27	990280	SEALING PLUG	1	15 IN LBS
28	990281	O RING	1	
29	361540	SCREEN, 1/2 HP HIGH SPEED	3	
30	772007	SCREW, #8-32 x 1/2" LONG	6	
31	771034	NUT, #8-32 HEX	6	



800 Deere Rd

Prescott, WI 54021

Phone: 715-262-4488 Fax: 715-262-4487

[www.Kascomarine.com](http://www.Kascomarine.com) [Sales@kascomarine.com](mailto:Sales@kascomarine.com)

## Repair Contact Form

- ❖ **Kasco requires all Repairs sent in MUST be accompanied by this form and marked to Repairs attention. (ex. Attn: Repairs)**
- ❖ **Repairs returned should include upper pump housing or wire basket for Aerators and De-Icers. These parts protect the motor during shipping.**
- ❖ **Kasco is NOT responsible for shipping damage accrued in return shipment.**
- ❖ **It is the responsibility of customer to ship and pay freight to Kasco.**
- ❖ **Do not ship float or control panel with unit, unless otherwise instructed**
- ❖ **A fee of \$60 per hour will be assessed for cleaning excessively dirty units and float disassembly**
- ❖ **Refer to the Owner's manual for easy-to-follow troubleshooting rule out site issue.**

**Note: Contact Information Should be that of the person or company to contact for repair.**

Company	First Name	Last Name
Address	City	State
Zip code	Phone #	Alternate Phone #
Email Address	Preferred method of contact (Circle) Phone                      Email	Purchase order #

Submersible Pump Information (Complete if sending unit)	Light kit Information (complete if sending lights)	Parts Included (For office use)
Model #	Model #	Unit <input type="checkbox"/>
Serial #	Serial #	Cord <input type="checkbox"/>
Cord Length:	Cord Length:	Light Kit <input type="checkbox"/>
Purchased from:	Purchased From	Float <input type="checkbox"/>
Purchase Date:	Purchase Date:	Control Panel <input type="checkbox"/>

Additional notes for technician.

## Registration Information

Please register your fountain online at:

[www.kascomarine.com](http://www.kascomarine.com)

Also fill in the information below and keep for your records.

Model # (Ex. 2400SF) \_\_\_\_\_

Serial # (Ex. 2101S241025) \_\_\_\_\_

Purchase Date: \_\_\_\_\_

Purchased From: \_\_\_\_\_

Registration Date: \_\_\_\_\_



Kasco Marine, Inc.  
800 Deere Rd.  
Prescott, WI 54021

Phone (715) 262-4488 \* Fax (715) 262-4487

[www.kascomarine.com](http://www.kascomarine.com) \* [sales@kascomarine.com](mailto:sales@kascomarine.com)