

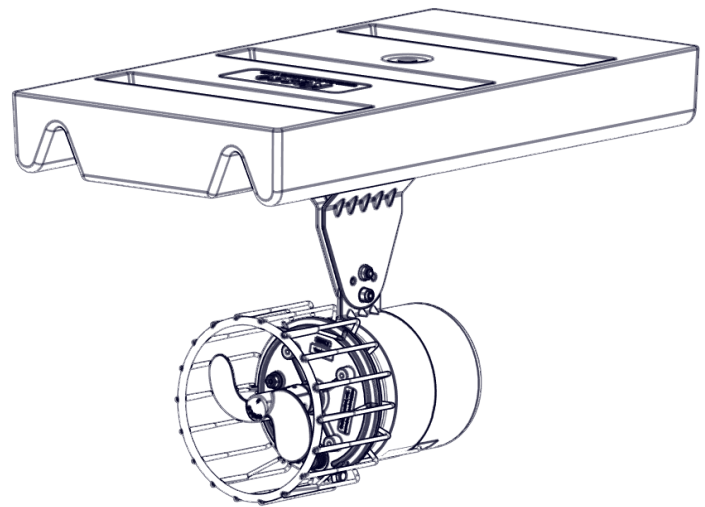

MOVING WATER FORWARD, SINCE 1968

AERATOR & CIRCULATOR

2400, 3400, 3400H,
4400, 4400H

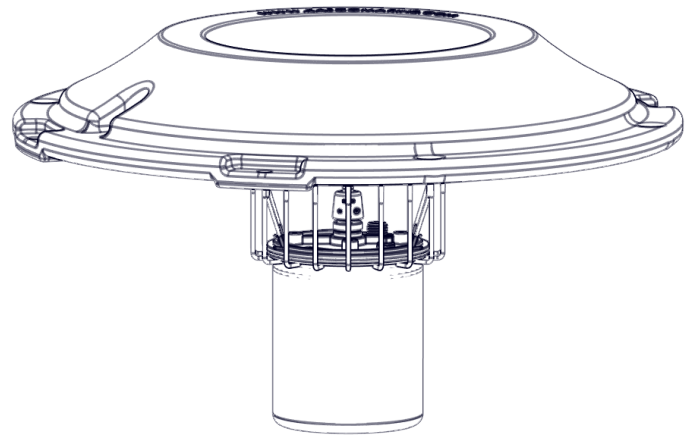

Operation & Maintenance Manual



Intertek 3020379
us ANSI/UL 778: 2016
Ed.6+R:22Feb2017
CSA C22.2 #108: 2014 Ed.5

Document number 884740

Document version 2021.1.1

800 Deere Rd. Prescott, WI 54021 | 715.262.4488 | sales@kascomarine.com | kascomarine.com

TABLE OF CONTENTS

Safety First.....	2
Unit Specifications.....	3
General Instructions.....	3
Parts Included (Aerator).....	4
Assembly Instructions (Aerator)	5
Parts Included (Circulator).....	8
Assembly Instructions (Circulator)	9
Installation Instructions.....	12
Maintenance Recommendations.....	13
Troubleshooting Tips.....	14
Unit Replacement Parts.....	16
Warranty	17
Repair Contact Form	19

QUESTIONS?



715.262.4488



kascomarine.com | sales@kascomarine.com

SAFETY FIRST

IMPORTANT: PLEASE READ THIS MANUAL AND SAVE FOR FUTURE REFERENCE

WARNINGS:



Moving Machinery



Shock Hazard

Please read and follow these extremely important safety and handling instructions for your Kasco equipment. Following these instructions will help ensure your safety and the quality performance of your equipment.

- Under NO circumstances should anyone enter the water with the electrical equipment plugged in and/or in operation. All Kasco equipment is ETL approved to UL and CSA standards for safety in water. However, it is NEVER recommended to enter the water with the equipment in operation.
- Use caution when dealing with any electrical and/or moving equipment.
- NEVER run the unit out of water. It will damage the seals and create a dangerous situation for the operator.
- Use extreme caution around water, especially cold water, such as in spring, fall, and winter, which poses a hazard in itself.
- NEVER lift or drag the equipment by the power cord. If you need to pull the unit to the side of the pond, use the anchoring ropes or mount apparatus.
- Do not use waders in deep ponds/lakes or ponds/lakes with drop-offs, drastic slopes, or soft bottom material.
- Do not use boats that tip easily, such as canoes, for installation, and follow all boating safety rules and regulations, including wearing a PFD (Personal Flotation Device).
- Single phase water aerators are supplied with an internal grounding conductor and a grounding-type attachment plug. To reduce the risk of electrical shock, be certain that the water aerator is plugged into a GFI-protected circuit.
- Control panels must be installed a minimum of 5ft (1.5m) from the inside wall of the pond, unless separated from the body of water by a fence wall, or other permanent barrier that will make the unit inaccessible to persons in the water.
- Control panels must be installed by a qualified electrician.
- Ground Fault Circuit Interrupters (GFCI) should be tested upon each installation and every month thereafter to ensure proper operation.
- Please keep the original box for maintenance shipping.

UNIT SPECIFICATIONS

Model	Voltage	Operating Amps	Locked Rotor Amps
Single-phase Aerators and Circulators			
2400A/C	110-120	5.0	12
3400A/C	110-120	6.7	18
3400HA/HC	208-240	3.4	9
4400A/C	110-120	11.3	40
4400HA/HC	208-240	5.7	20

GENERAL INSTRUCTIONS

Inspect the Shipment

Immediately inspect your shipment for any visible damages. Any damage should be reported immediately to your carrier and Kasco.

Assembly & Installation

Please see the proper assembly and installation Instructions enclosed in this manual. Each is specific for your model and size of aerator or circulator. Note: It is extremely important to test the GFI breaker in the control panel upon each installation/re-installation of the unit to ensure proper functioning.

Use and Operation

Kasco Aerators are designed and engineered for continuous duty, such as on fish farms or other aquaculture applications, or on-demand use, as needed in a recreational water feature. During flotation operation, the water is pulled from 360° around the unit and from below the unit. Following installation, your Kasco aerator or circulator is ready for immediate use. Make sure to keep the motor housing clean from hard water deposits and/or algae. (See Maintenance Recommendations.) Kasco aerators/circulators are lightweight, energy efficient, and easy to install and operate.

SUGGESTED TOOLS & SUPPLIES

	Aerator	Circulator
#2 Phillips-head screwdriver	✓	
3/8" socket or wrench	✓	✓
9/16" socket or wrench	✓	✓
Anchors or stakes for installing unit	2 or 3	3
12" pieces of 1" galvanized pipe (optional, see page 12)	2 or 3	3

PARTS INCLUDED (AERATOR)

Item	Description	Qty	Part No.
A	1/4"-20 x 3-1/2" screw	3	251210
B	1/4" split lock washer	3	840537
C	1/4", 3/4" OD flat washer	3	251300
D	Float	1	242003
E	Float retaining clip	3	222995
Optional Bottom Screen Assembly			
F	3/8"-16 x 2-1/2" hex head screw	2	820095
G	3/8" flat washer	4	462216
H	Bottom screen	1	990162
I	Bottom screen clip	2	223240
J	3/8"-16 nut	2	462214

3 mooring ropes —

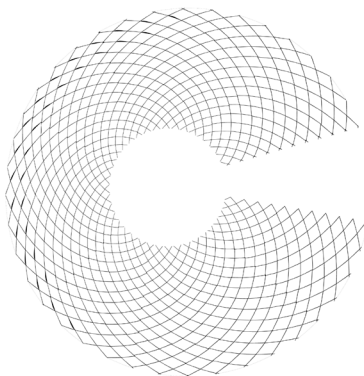
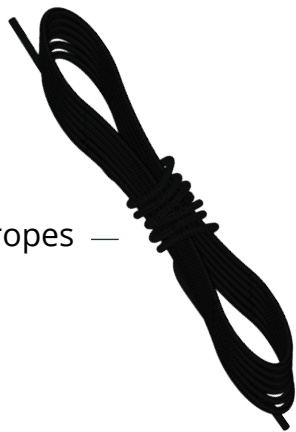

Optional mesh screen

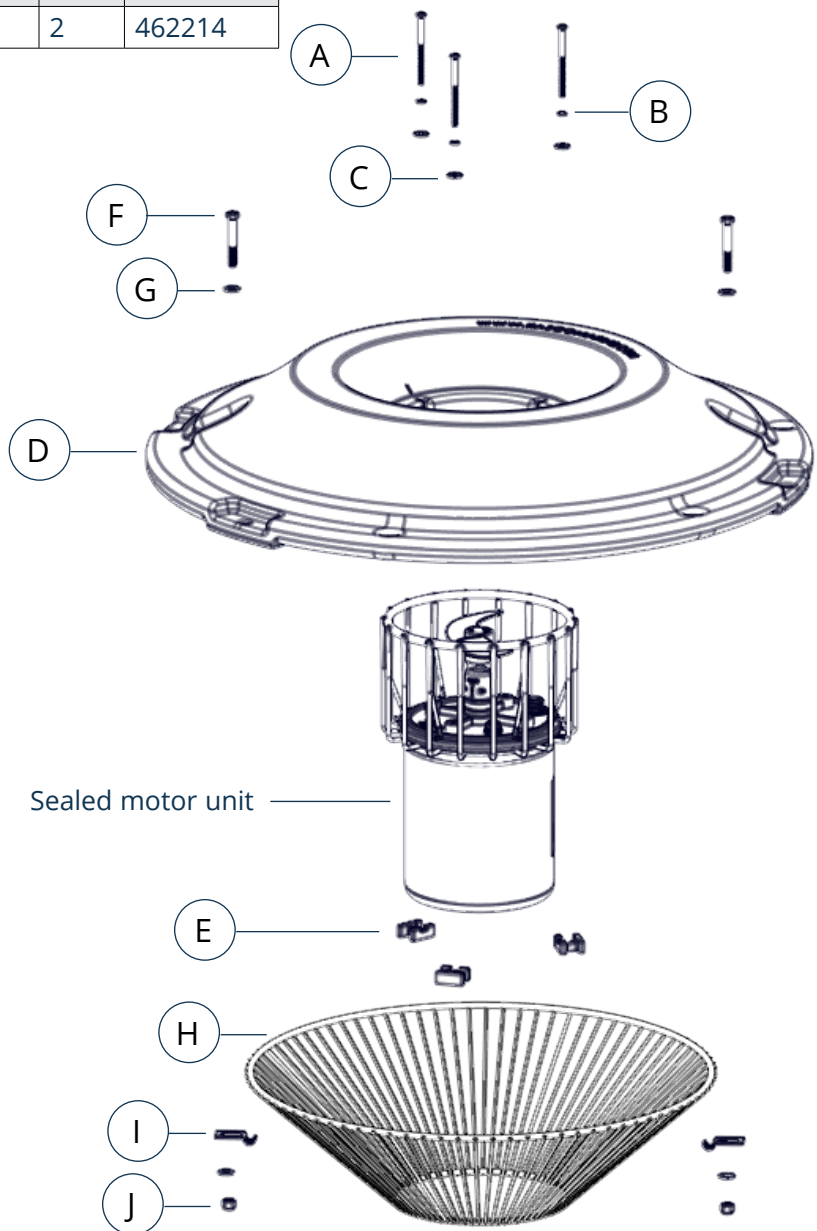

ASSEMBLY INSTRUCTIONS (AERATOR)

1. Rest the float (D) on the cage, aligning the power cord to the notch in the float.

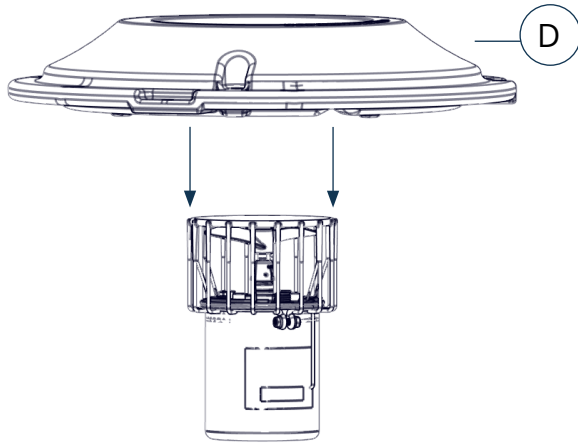

Align power cord with this notch

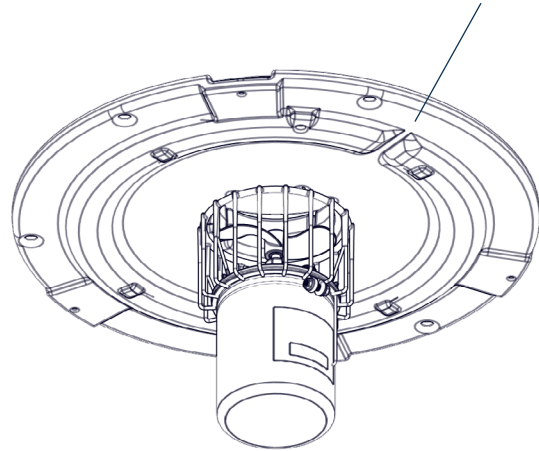

2. Locate the bolt holes marked with the indicators.

Indicator mark

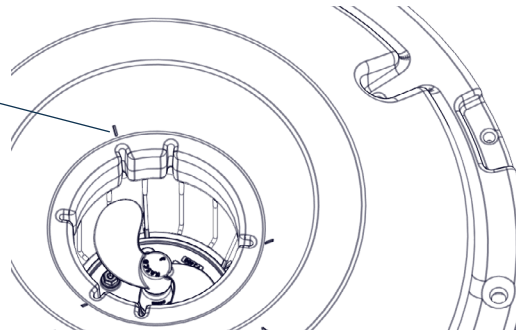

3. Secure the float to the cage with the 1/4"-20 x 3-1/2" screws (A), 1/4" split lock washers (B), 3/4" OD flat washers (C), and float retaining clips (E), as shown below.
4. Repeat for all three bolt holes.

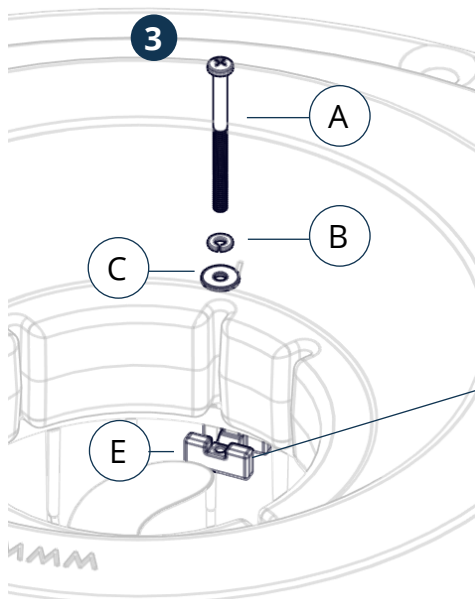

Secure to top ring of cage

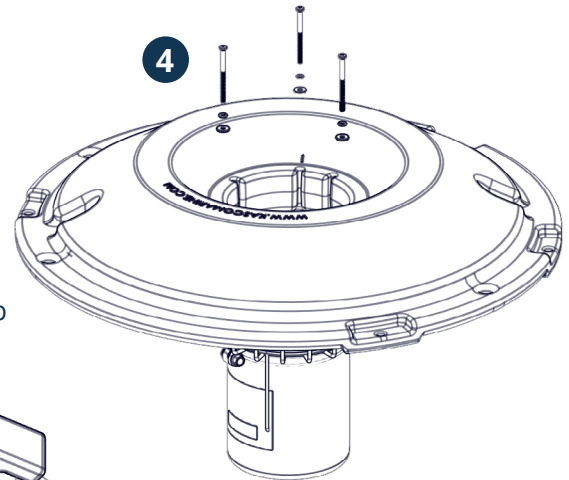
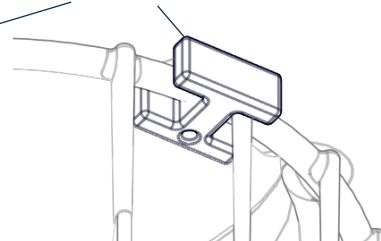

ASSEMBLY INSTRUCTIONS (AERATOR, CONT.)

If you are **not** installing a mesh screen with your bottom screen, continue to step 10.

If you are **not** installing a bottom screen, continue to step 12.

5. Wrap the flat mesh into a cone shape by overlapping both vertical edges by approximately 1 inch and aligning the top and bottom edges of mesh.
6. Use three cable ties evenly spaced along the vertical seam to secure the mesh at the top, middle, and bottom.
7. Center the stainless steel bottom screen inside the mesh cone with approximately 2 inches of mesh above the steel screen's large ring.
8. Use three cable ties evenly spaced around the large ring to attach the mesh to the steel screen.
9. Use two cable ties placed opposite each other on the small ring to further secure the mesh to the screen.

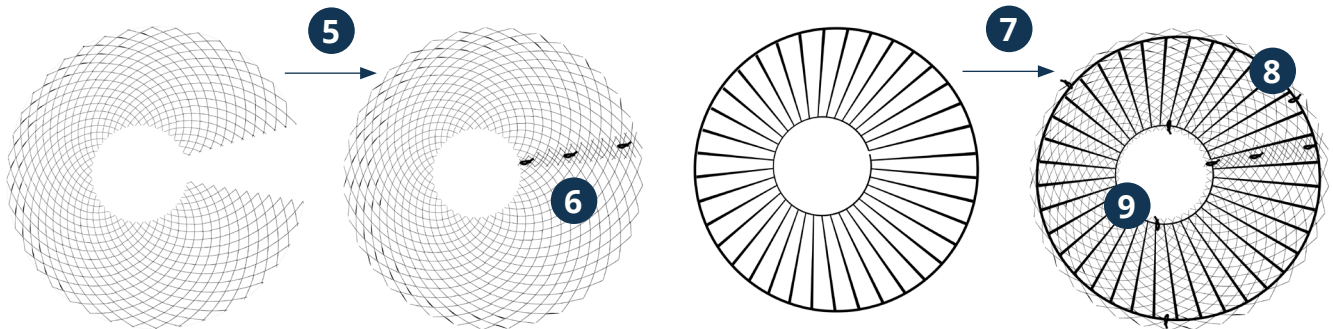

10. Turn the unit upside down and position the bottom screen (H) flush with the float.

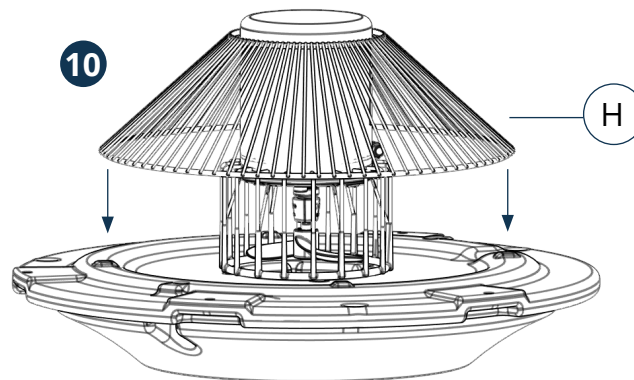

ASSEMBLY INSTRUCTIONS (AERATOR, CONT.)

10. Turn the unit upside down and position the bottom screen (H) flush with the float.
11. Fasten the bottom screen to the float using the 3/8"-16 x 2-1/2" screws (F), 3/8" flat washers (G), bottom screen clips (I), and 3/8"-16 nuts (J).

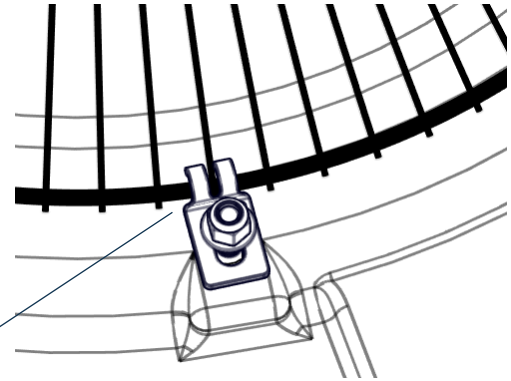
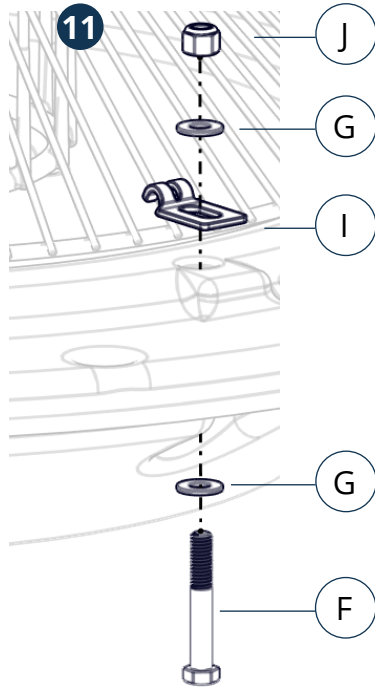

Position the clip flanges on either side of a vertical bar

12. Loop the mooring lines through either two or three evenly spaced holes on the float.
13. Attach the strain relief to the line closest to the cord. Make sure to clip both the loop and one side of the rope between the knot and the float to ensure the clip doesn't move down the rope.
14. Continue to aerator installation instructions on page 12.

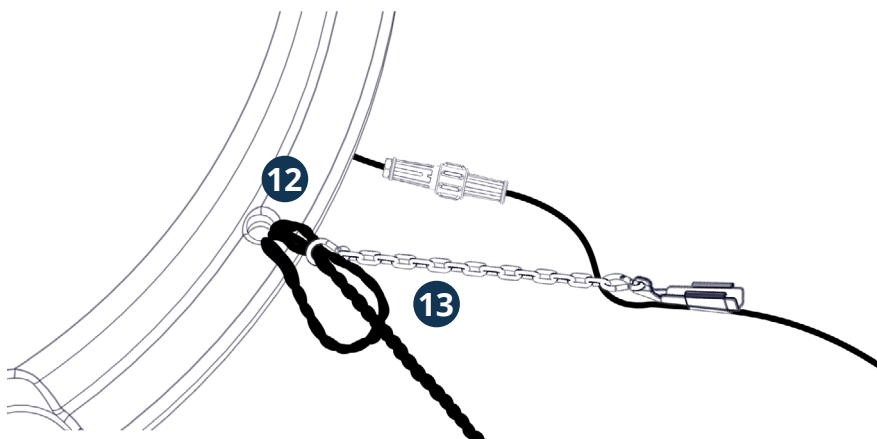

NOTE  If your cord does not have a strain relief clamp and chain attached, you can secure the cord to one of the float holes.

PARTS INCLUDED (CIRCULATOR)

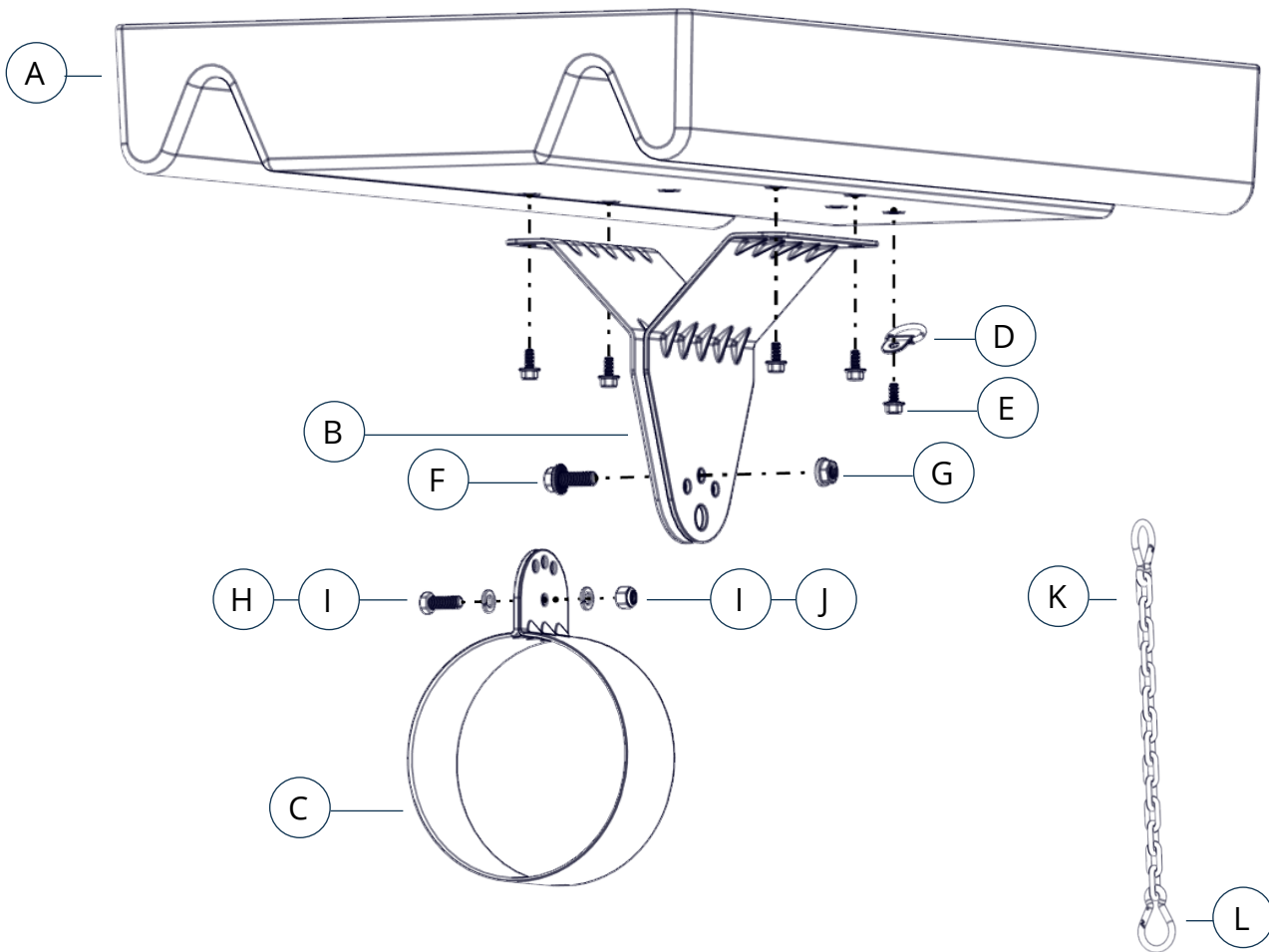

3 mooring ropes —

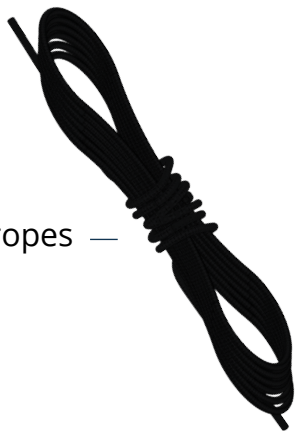

ID	Description	Qty	Part #
A	Horizontal Float	1	213002
B	Horizontal Float mounting bracket	2	993220
C	Can strap	1	997174
D	Tie-down ring	1	993230
E	1/4"-20 x 1/2" serrated flange screw	5	774037
F	3/8"-16 x 1" serrated flange screw	1	840533
G	3/8"-16 serrated flange nut	1	840532
H	3/8"-16 x 1" hex head cap screw	1	566250
I	3/8" flat washer	2	462216
J	3/8"-16 nut	1	462214
K	Chain (12" length)	2	636344
L	Snap clip	4	636346

ASSEMBLY INSTRUCTIONS (CIRCULATOR)

1. Slide the can strap (C) onto the unit with the flanges directly opposite the cage clamp. The strap should be about 1.5 inches from the cage.
2. Secure the flanges together by fitting a 3/8"-16 x 1" hex head cap screw (H), two 3/8" flat washers (I), and a 3/8"-16 nut (J) in the hole closest to the can.
3. Fit the bottom hole of each mounting bracket (B) over the hardware now securing the can strap flanges.

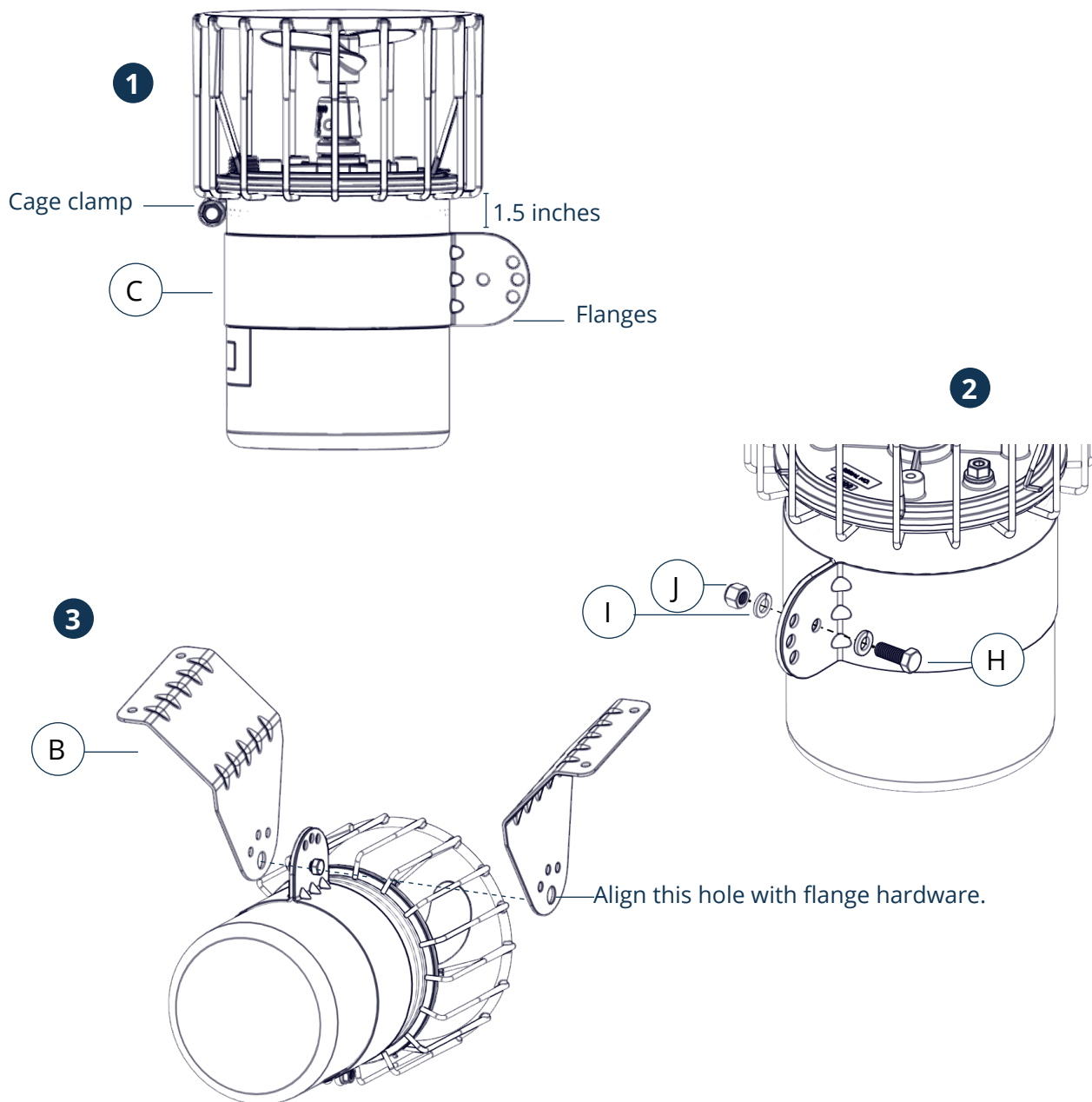

ASSEMBLY INSTRUCTIONS (CIRCULATOR, CONT.)

4. Angle the unit as desired by aligning one of the three the holes in the flanges with the corresponding holes in the brackets. Secure the can strap to the brackets with the 3/8"-16 x 1" serrated flange screw (F) and 3/8"-16 serrated flange nut (G) to fix the unit in one of the angles below.

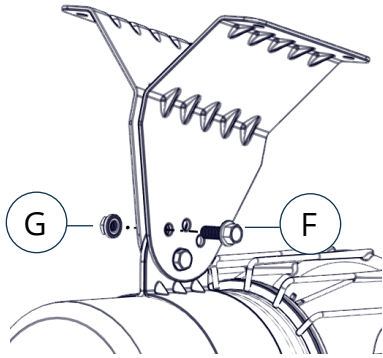

Upward angle: Align the bracket and flange holes furthest from the cage to angle the unit toward the float in the water (below).

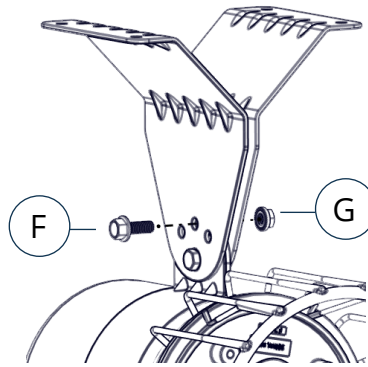
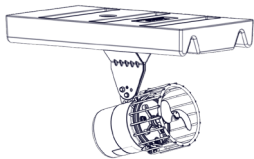

No angle: Align the center holes in the brackets and flanges to angle the unit straight ahead in the water (below).

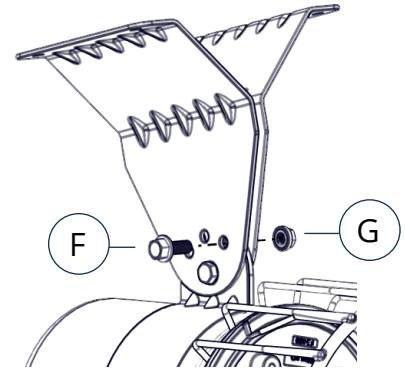
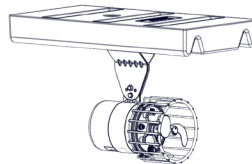

Downward angle: Align the bracket and flange holes closest to the cage to angle the unit away from the float in the water (below).

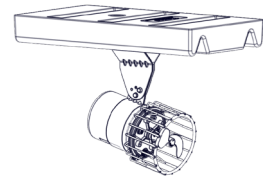

5. Place the float on a stable surface with the flat side down and use four 1/4"-20 x 1/2" serrated flange screws (E) to secure the mounting brackets (B) to the float.

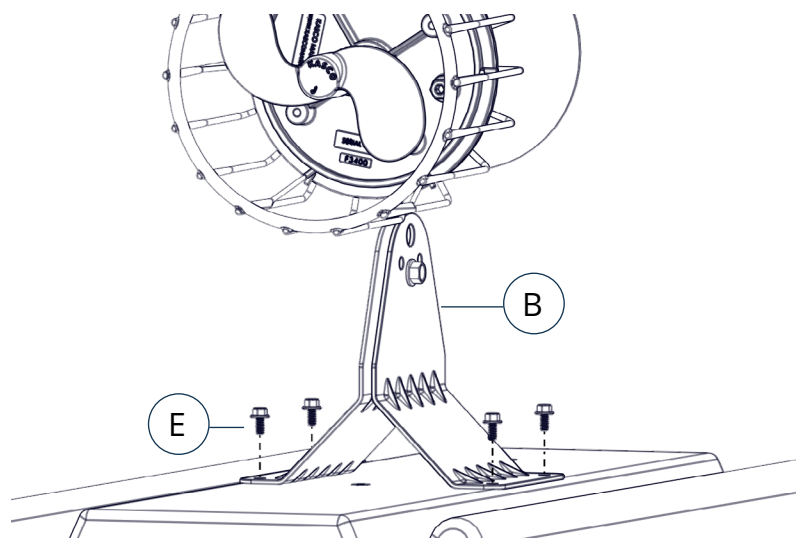

ASSEMBLY INSTRUCTIONS (CIRCULATOR, CONT.)

- Secure the tie-down ring (D) to the float using another 1/4"-20 x 1/2" serrated flange screw (E).
- Attach snap clips (L) to both ends of both chains (K).
- Use the snap clips to attach the chains to the cage as shown below, evenly spaced on either side of the cage clamp.

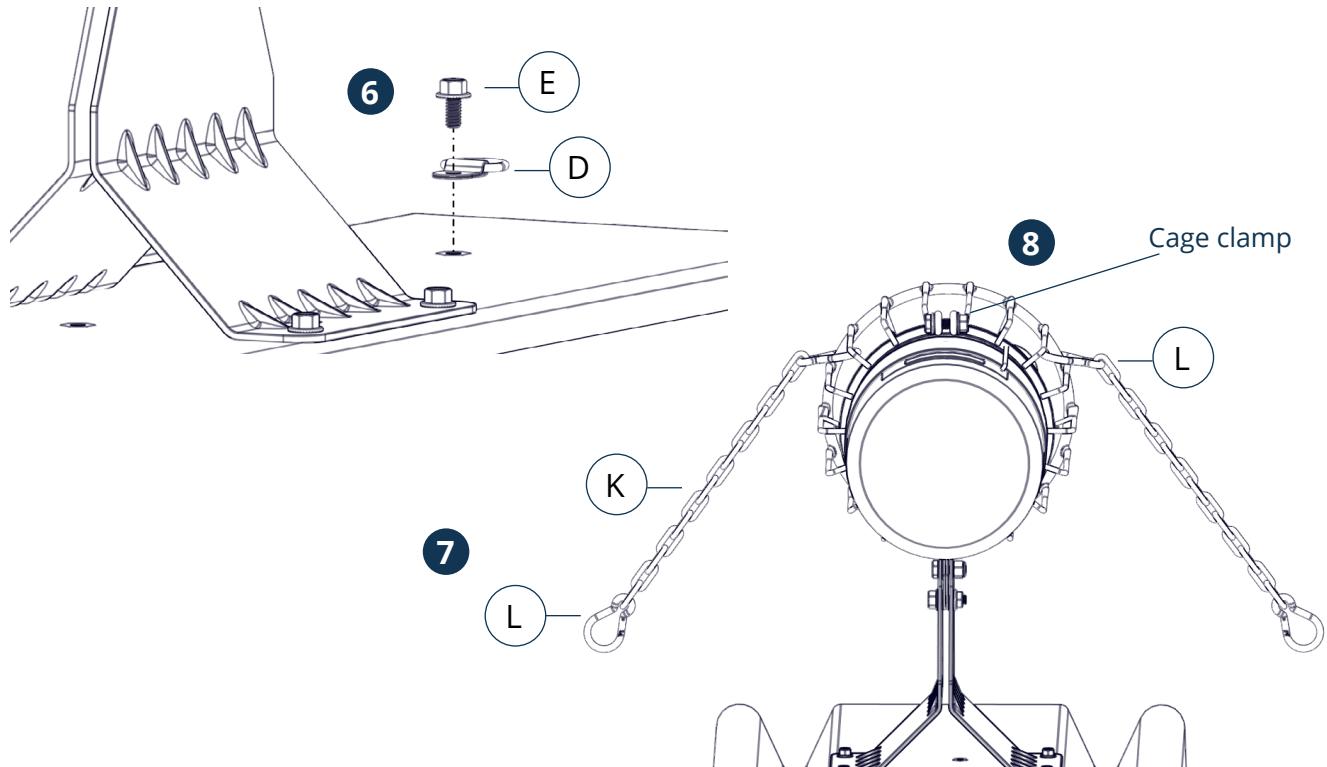

- Tie mooring ropes to both chains and to the tie-down ring to provide three anchor points for the unit and float (A) as shown below.
- Attach the chain from the cord strain relief assembly to the tie-down ring on the float.
- Continue to circulator installation instructions on page 12.

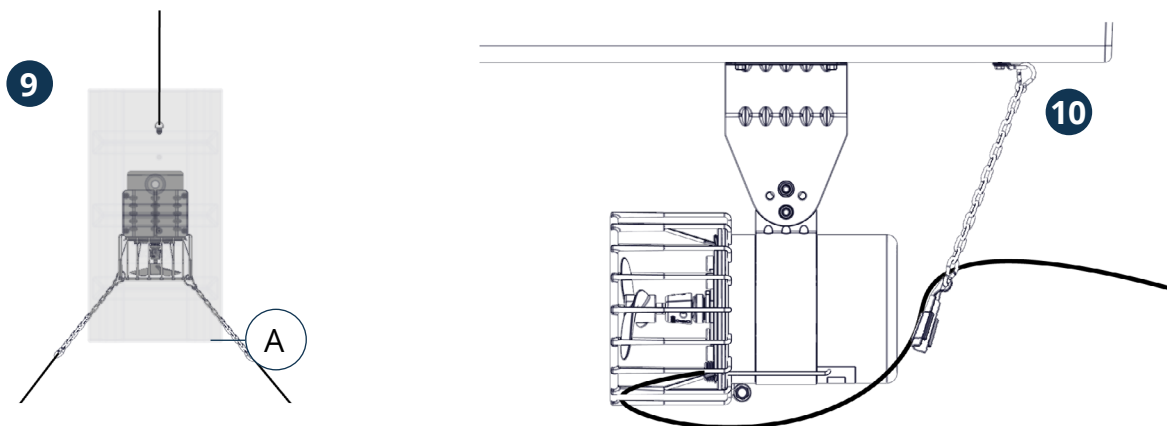

NOTE If your cord does not have a strain relief clamp and chain attached, you can use a spare cable tie to secure the cord to the tie-down ring on the horizontal float.

INSTALLATION INSTRUCTIONS

Use ropes to position the aerator or circulator in the desired location in the pond or lake. Anchor the ropes or secure them to the shoreline so that they are free of slack, but not tight. To prevent twisting of the unit due to motor torque, place the anchor at least 3 feet from the float for each foot of depth. (Example: a 6-foot-deep pond would require an anchor 18 feet horizontally from the float.)

Correct anchoring

Mooring lines are proper length and taut between unit and anchors.

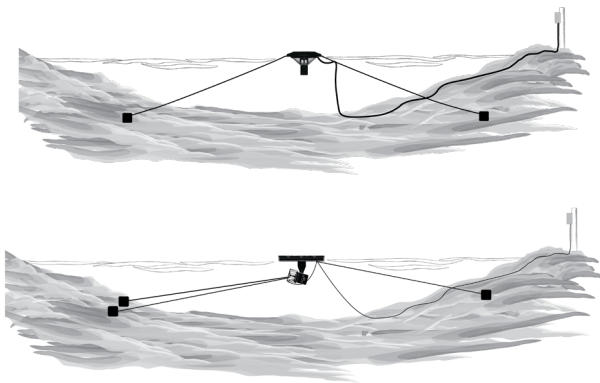

Incorrect anchoring

Mooring lines are too short or loose between unit and anchors.

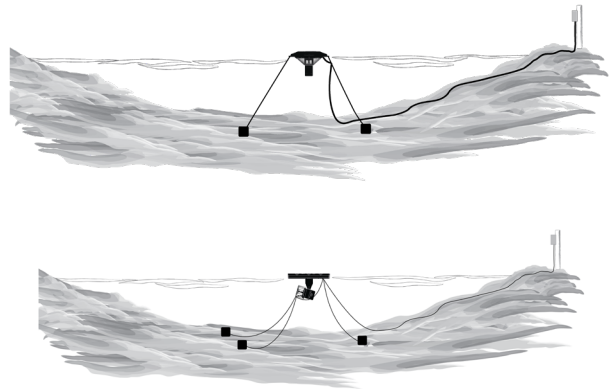

Alternate Installation

In ponds where the water level fluctuates significantly, a small weight may need to be suspended at the midpoint of the rope to take up any slack caused by a drop in water level (1 foot of 1-inch galvanized pipe works well). The weight should be light enough so that the aerator can rise as the water level rises. This weight can also help hide the anchoring ropes by sinking them further below the surface (shown with unit; use same method with three lines for circulator).

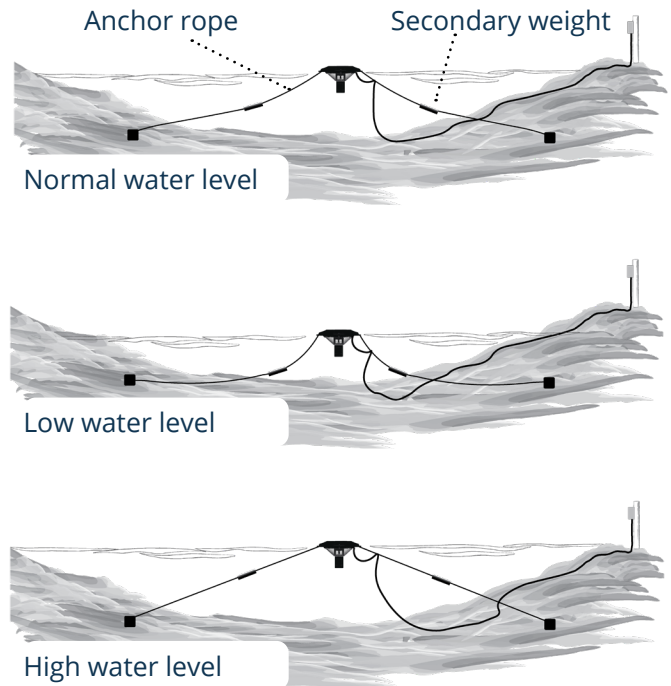

MAINTENANCE RECOMMENDATIONS

UNDER NO CIRCUMSTANCES should anyone enter the water while equipment is operating.

The following maintenance procedures can ensure many years of quality performance from your Kasco aerator or circulator and reduce the need for more costly repair work.

Proper Installation

Proper installation of Kasco equipment will include a power source with Ground Fault Interruption (GFI). Ground fault interrupters are a safety feature that can also alert you to electrical leaks in the equipment. It is extremely important to test the GFI upon installation, following each re-installation, and monthly thereafter to ensure proper operation. If you have repeat/consistent trips on your ground fault, disconnect the equipment and remove it from the water. Inspect the power cord for damage and call Kasco Marine at 715- 262-4488 for further instructions.

Observation

Operating equipment should be observed on a regular basis (daily, if possible) for any reduction or variation in performance. If you observe a change in performance, disconnect the equipment from its power source and inspected for any material that may have clogged the system or wrapped around the shaft of the motor, especially plastic bags and fishing line. Even though Kasco aerators and circulators are among the most clog-resistant on the market, it is impossible to protect against all items that can clog equipment and still maintain a flow of water. These materials can be very damaging to the equipment under continuous operation and must be removed as soon as possible.

ALWAYS UNPLUG THE UNIT BEFORE ATTEMPTING TO REMOVE CLOGS.

Winter Storage

In regions where there is significant freezing in the wintertime, remove the aerator or circulator from the water to protect it from the expansion pressure caused by ice. In many areas, aerators will keep some amount of ice open through the winter. However, when the water is thrust into the air, it is exposed to the colder air temperatures longer and can actually make ice thicker on the pond/lake. Storage over winter is best in a location that is out of the sun and cool, but above 32 degrees Fahrenheit. During the offseason, store units upside down (with the float down) if they are going to be sitting for long periods of time. Units that sit upright on a shelf for many months, or even years have a greater likelihood of seals drying out. Storing units upside down will help to ensure oil is lubricating the seals without damaging the propeller guard.

Cleaning

Aerators and circulators should be removed from the water at least once per year (at the end of the season in cold climates) to clean the exterior of the system, especially the stainless steel motor housing (can). The motor housing is the surface that dissipates heat into the water, and any algae, calcium, or other build-up will become an insulator that blocks heat transfer. In warmer regions, Kasco recommends removing the motor and cleaning it at least two to three times per year, depending on conditions. In most cases, a power washer will be sufficient if the unit and algae are still wet. Avoid power-washing the mechanical seal area directly.

MAINTENANCE RECOMMENDATIONS (CONT.)

Seal And Oil Replacement

This is a sealed motor assembly, and seals will wear out over time (similar to brake pads on a car). Replacing the seals and changing the oil after three years may add longevity to the operation of the motor, saving you the cost of more expensive repairs. In warmer climates where the aerator runs most or all of the year, it is a good idea to replace seals more regularly than you would need to in colder climates where the unit is removed from the water for several months.

Sacrificial Anode

A sacrificial anode is supplied on the shaft of all aerators for protection of the equipment from corrosion and electrolysis. The anode should be updated (replaced) if reduced to half the original size or if white in color. Corrosion from electrolysis is more commonly associated with saltwater or brackish water, but as a matter of precaution, it is important to periodically check the anode in all installations (at least every two to three months). Seal replacement and all other repair services should be performed by Kasco Marine or a Kasco Authorized Repair Center. Any alterations or changes made to Kasco units by an unauthorized source will void the warranty. This includes tampering with the unit, power cord, and/or control box. Please contact Kasco Marine, Inc. at 715-262-4488 for your nearest Authorized Repair Center.

TROUBLESHOOTING TIPS

Below are some helpful troubleshooting tips. If a problem occurs, please double-check the assembly and installation instructions as well as the instructions for the control panel. More troubleshooting tips can be found at www.kascomarine.com

"My aerator or circulator trips the ground fault interrupter in the C-85 or C-95."

This is the most common symptom of several possible problems. To correctly diagnose the problem, you will need to collect more information. A Ground Fault Interrupter (GFI) breaker that trips can indicate an electrical service problem, water contamination in the unit and/or cord, bad breaker, control box problems, motor problems, etc. Try to find out the answers to these questions before you contact Kasco to narrow down the problem.

- How long does it take to trip the breaker?
- Does it always take the same amount of time to trip?
- How many times has it tripped?
- Have there been any recent electrical problems in the area?

"My aerator or circulator seems to run slowly."

This can also be a symptom of several possible problems. There could be an electrical problem where the unit is not getting the proper voltage. This could also indicate a problem with the motor of the unit, which needs to be looked at by an Authorized Repair Center. Check that the unit is receiving the proper voltage, and, if so, contact Kasco for further steps.

TROUBLESHOOTING TIPS (CONT.)

“My aerator or circulator hums, but will not start. When I spin the prop with a stick, it starts up.”

(for single phase units only) This indicates a problem with the starting capacitor. Each Kasco aerator/circulator is equipped with a starting capacitor to get the unit going when it is first plugged in. If it is operating but not spinning and can be started by spinning the prop with a stick, the starting capacitor needs to be replaced by an Authorized Repair Center.

“My aerator or circulator turns itself off and back on without the timer and without tripping the GFI breaker.”

(for single phase units only) Each Kasco unit has a thermal overload built in that will turn the unit off when it overheats. Once the unit has cooled down, it will start back up. If you are noticing these symptoms, the unit should be unplugged immediately because the thermal overload will continue to turn on and off until it burns out and damages the motor. The unit should be unplugged and taken out of the water to find the cause of the problem. The problem could be one of many, such as low water levels, build-up on the unit to prevent heat dissipation, something inhibiting the free rotation of the shaft, etc. If something is caught in the unit, or if there is buildup on the unit, remove the debris. If caught early enough, the unit should be fine. Contact a Kasco representative before restarting the unit.

“My aerator or circulator flow seems to fluctuate and/or be less than usual.”

This can occur because of a few different reasons. Most of the time, this symptom is caused by the unit being clogged with debris. A mat of weeds, many leaves, plastic bags, etc., can clog up the unit and cause it to be starved of water. If the unit does not have the proper amount of water, the flow or pattern will fluctuate up and down and look sporadic. If you are seeing these symptoms, first try turning off the unit and/or unplugging it for 10 seconds, allowing debris to fall away. If the problem persists, unplug the unit and clean away any debris that is clogging up the guard. Another possibility is a chipped or damaged prop that is causing the unit to wobble and not pump properly. When the unit is unplugged, check the prop and replace it if it is damaged.

“The GFI breaker trips randomly and sporadically. Sometimes it is after a few hours of operation; other times it can be days or weeks.”

This is referred to as a nuisance trip. This usually occurs where the unit is installed a great distance from the initial electric service on the property where the ground stake is placed. It is caused by either induced current in the ground wire or a base voltage difference due to soil pH levels. Contact an electrician and install a local grounding stake. This may eliminate the induced current and any base voltage differences.

UNIT REPLACEMENT PARTS

ID	Description	Qty	Part #
A	2400 model propeller	1	240170
A	3400 model propeller	1	340125K
A	4400 model propeller	1	440430
B	Sacrificial anode assembly (1/2" shaft)	1	243475
B	Sacrificial anode assembly (5/8" shaft)	1	840475
C	Cage	1	990200
D	3/8"-16 x 1-1/4" serrated flange screw	1	840543
E	3/8"-16 serrated flange nut	1	840532

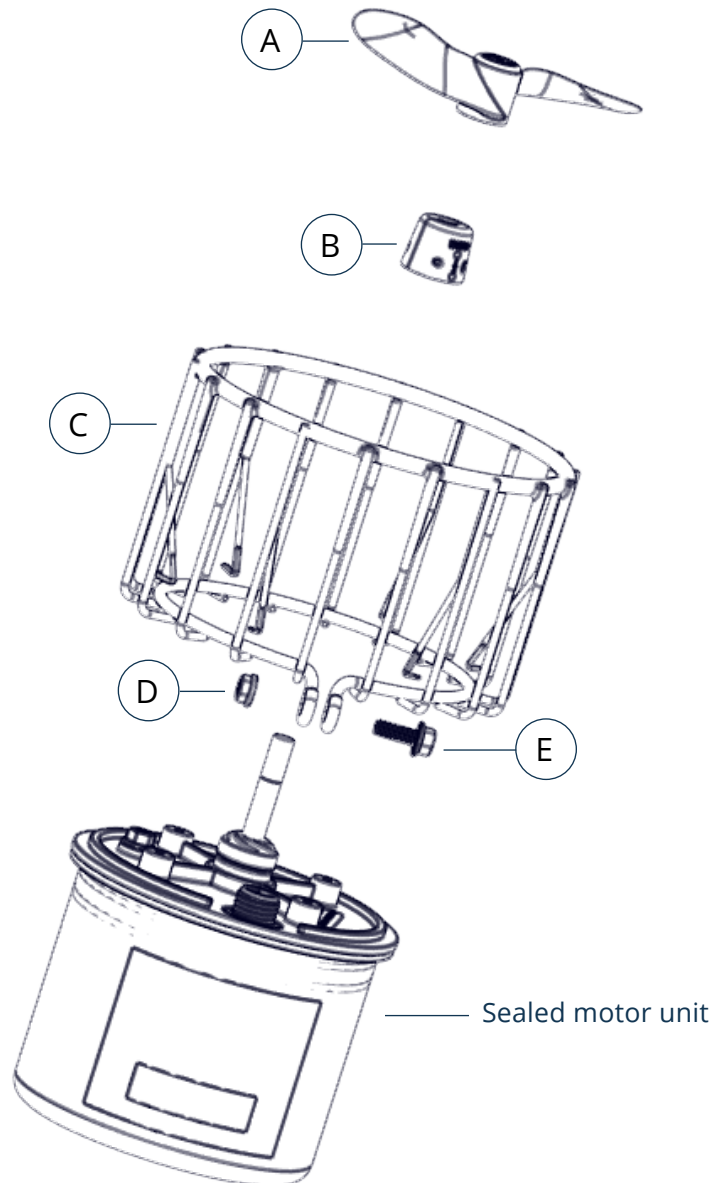

WARRANTY

Warranty Period: Models 2400A/C, 3400A/C, 3400HA/HC, 4400A/C, 4400HA/HC = 2 years

Kasco® Marine, Inc. warrants this aerator/circulator to be free from defects in material or workmanship (except for the ropes, power cord, and propeller) under normal use and service. The Kasco Marine, Inc. obligation under this warranty is limited to replacing or repairing free of charge any defective part within the warranty period. Customer shall pay shipping charges for returning the unit to Kasco or an Authorized Repair Center.

THIS WARRANTY IS IN LIEU OF ANY OTHER WARRANTIES, EXPRESSED OR IMPLIED, AND ANY OTHER OBLIGATION OR LIABILITY WHATEVER ON THE PART OF KASCO MARINE, INC. AND IN NO EVENT SHALL KASCO MARINE, INC. BE LIABLE FOR ANY SPECIAL OR CONSEQUENTIAL DAMAGES.

Warranty is void if:

- The unit is not maintained properly according to the Maintenance Recommendations supplied in this manual.
- The unit is returned for repair without the power cord or if the unit, control box, or power cord are altered in any way from original shipment. Cuts in the power cord are not covered under warranty.
- The unit is damaged by unauthorized tampering.
- The sacrificial anode around the propeller shaft shows significant deterioration. (The anode must be inspected periodically and replaced if necessary.)

Warranty Claim Procedure: The best method for establishing warranty period is via the original receipt. Also, register the unit online at: www.kascomarine.com. Once the warranty coverage has been established, the unit may be sent to any Kasco Authorized Repair Center for evaluation and repair. Please call Kasco Marine at 715-262-4488 prior to shipping to receive any updated information and/or repair form or call Kasco Marine at 715-262-4488 to locate your nearest Authorized Repair Center. You can also email Kasco at sales@kascomarine.com.

Please include the repair form received from Kasco Marine or your local distributor with the shipment. If no repair form is available, include your name and physical address for return delivery of the repaired unit and a daytime phone number and/or e-mail address for correspondence regarding the warranty claim. Any expedited shipping method for the return of the unit is at the customer's expense. Kasco Marine will return units repaired under warranty at our expense via ground freight within the continental United States.

Other Repairs

Most failed equipment can be repaired at substantially lower costs than replacement with new. Please ship according to the instructions in the previous section.

Kasco Marine does estimates on repairs at the request of the customer. The request for an estimate should be included in the letter that accompanies the returned unit and must include a daytime phone number and/or e-mail address. Estimate options are as follows:

- We will contact the customer with a total estimated cost for repairs after we have evaluated the unit but before we perform the work.
- We will repair the unit only if repair costs are under a dollar amount stated by the customer. Example: "Please repair if total is under \$150.00 before shipping charges."

All estimates that are rejected for repair will be destroyed unless otherwise directed by the customer. If the customer would like the unit returned, the unit will be restored as closely as possible to the condition in which it was received and shipped at the customer's expense for shipping and handling charges.

Billing: Kasco Marine also accepts Visa and MasterCard credit card payments. Kasco Marine will call for credit card information upon completion of the estimate at the customer's request. All other warranty and repair inquiries should be directed to Kasco Marine, Inc. at 715-262-4488 or repairs@kascomarine.com



Kasco only accepts complete assemblies for warranty repair. We must receive the power cord and all other components with the motor as originally assembled. Kasco will bill the customer to replace any missing parts necessary for repair. It is not necessary to return the control panel, mount, or other parts with the motor assembly, unless specifically requested by a Kasco representative.

Please attach a repair form with the shipment. The repair form must include a name, physical address (for return delivery of the repaired unit), daytime phone number, and an e-mail address for correspondence regarding the warranty claim.

Any expedited shipping method for the return of the unit is at the customer's expense. Kasco Marine will return units repaired under warranty at our expense via ground freight within the continental United States.

CONTACT US



Kasco Marine
800 Deere Road
Prescott, WI 54021



715.262.4488



kascomarine.com | sales@kascomarine.com



3020379
ANSI/UL 778: 2016
Ed.6+R:22Feb2017
CSA C22.2 #108: 201

REPAIR CONTACT FORM

- Kasco requires that all equipment sent for repair MUST be accompanied by this form and marked to Repairs attention.
- Unit should be cleaned before shipping.
- Kasco is NOT responsible for shipping damage accrued in return shipment.
- It is the responsibility of the customer to ship and pay freight to Kasco.

Kasco Marine
 800 Deere Road
 Prescott, WI 54021
 Attn: Repairs

Note: Contact information should be that of the person or company to contact for repair information.

Company name			
Contact name	First name	Last name	
Address	Street		
	City		
	State		
	ZIP code		
Phone number	Primary	Alternate	
Email address			
Preferred method of contact (circle one)	Phone	Email	
Purchase order number			
Additional product information	Serial Number	Cord Length	
Information for Repair Technician			
Was this unit used in a chemical treatment or wastewater application? (circle one)	Yes	No	
Additional notes			