

Kasco®

Owners Manual

PicoCell 3500 60 Hz



PicoCell™, PicoBlender™, and SolSwitch™, are trademarks of SunTech Drive LLC

SunTechDrive
A Premier Energy Holdings Company

Kasco Marine, Inc.
800 Deere Rd.
Prescott, WI 54021
PH (715) 262-4488
kascomarine.com

Manual Number
884821

Rev 12-2020

Table of Contents

Important Safety	pg. 2
PicoCell At-a-Glance	pg. 3
PicoCell Overview	pg. 4
Installation Requirements	pg. 5
Mounting Instructions	pg. 6
Wiring Instructions	pg. 7-8
Operations	pg. 9
Troubleshooting	pg. 10

Important Safety:

Please read and follow these important instructions to help ensure your safety and the quality performance of your Kasco equipment. This manual contains important instructions that should be followed during installation, operation, and maintenance of the PicoCell controller.

Carefully read and follow all safety instructions in this manual. Make sure that safety labels are always in good condition and replace any missing or damaged safety labels.

- Caution should be used when dealing with any electrical and/or moving equipment.
- **Under NO CIRCUMSTANCE should anyone enter the water with the electrical equipment plugged in and/or in operation.**



Warning
Risk of Electrical Shock
Disconnect Power Before Removing Door Cover
Caution
Risk of Electrical Shock



Before performing any service or maintenance inside the controller, or when connecting or disconnecting any wires, DISCONNECT the power and wait 90 seconds to allow the capacitor bank inside the controller to discharge to a level below 50Vdc.

Do Not:

- Turn on the power to the controller before terminating all wiring connections and closing the cover door.
- Connect power wiring to the controller before mounting the box.
- Service the device if your hands are wet or damp. Always make sure hands are dry before working on the controller.
- Modify inside the controller.
- Remove any parts of the controller unless instructed by this manual.

Product-at-a-Glance

The PicoCell 3500 is an off-grid solar controller that can operate most alternating current (AC) motors up to 2HP single-phase and 3HP three-phase from solar panel power. The PicoCell has a unique functionality that enables users to match an AC load with solar power.

A typical diagram for a PicoCell-operated Kasco surface aerator is below. The solar panels should be connected to the PicoCell controller via the integrated DC Disconnect. The PicoCell controller should be installed in the shade (potentially mounted under the solar panels) and away from the direct sun.



The PicoCell controller consists of several components, as shown below. The unit has five wire glands: one large gland for a motor cable (middle), two glands for solar panels (right side), and two glands for data cables (left side). There is direct access to the power and signal terminals on the DIN rail once the enclosure door is removed. The PicoCell controller should be mounted on a wall or other vertical surface using the back bracket (see below). On the back side of the unit there are four set screws used to hang the unit on the back bracket.

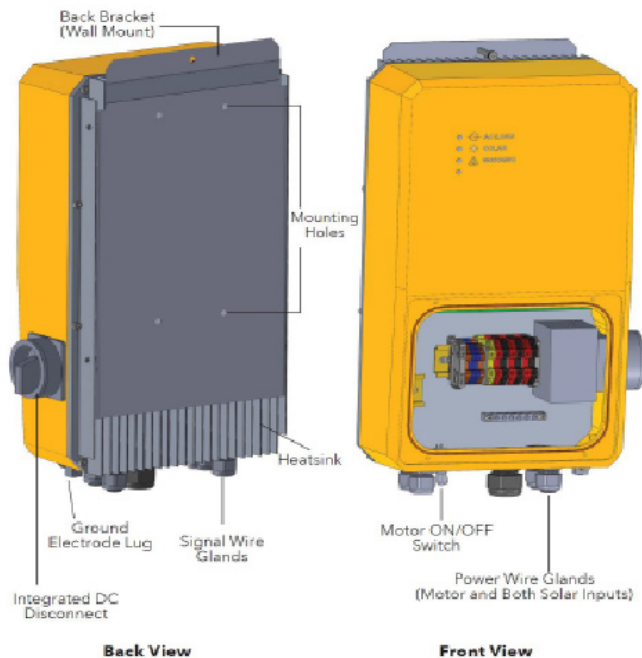

Overview

The Features of the PicoCell controller are shown below. The unit has five wire glands: two solar PV inputs, one motor output, and two glands for the external sensors.

Three LEDs are used to indicate the PicoCell controller's operation. On the bottom left, next to the external sensors glands, there is a motor ON/OFF switch that controls the PicoCell's operation of the motor.

Once the door of the enclosure is removed, there is access to the input terminal blocks (DIN rail mounts) on the right. Below the DIN rail is a grounding block for connecting the equipment ground. **The installer should only use the DIN rail terminals for connecting all external wires to the PicoCell unit.** The smaller DIN rail on the lower left is used for an optional WiFi communication (comm) board, which can be purchased upon request.

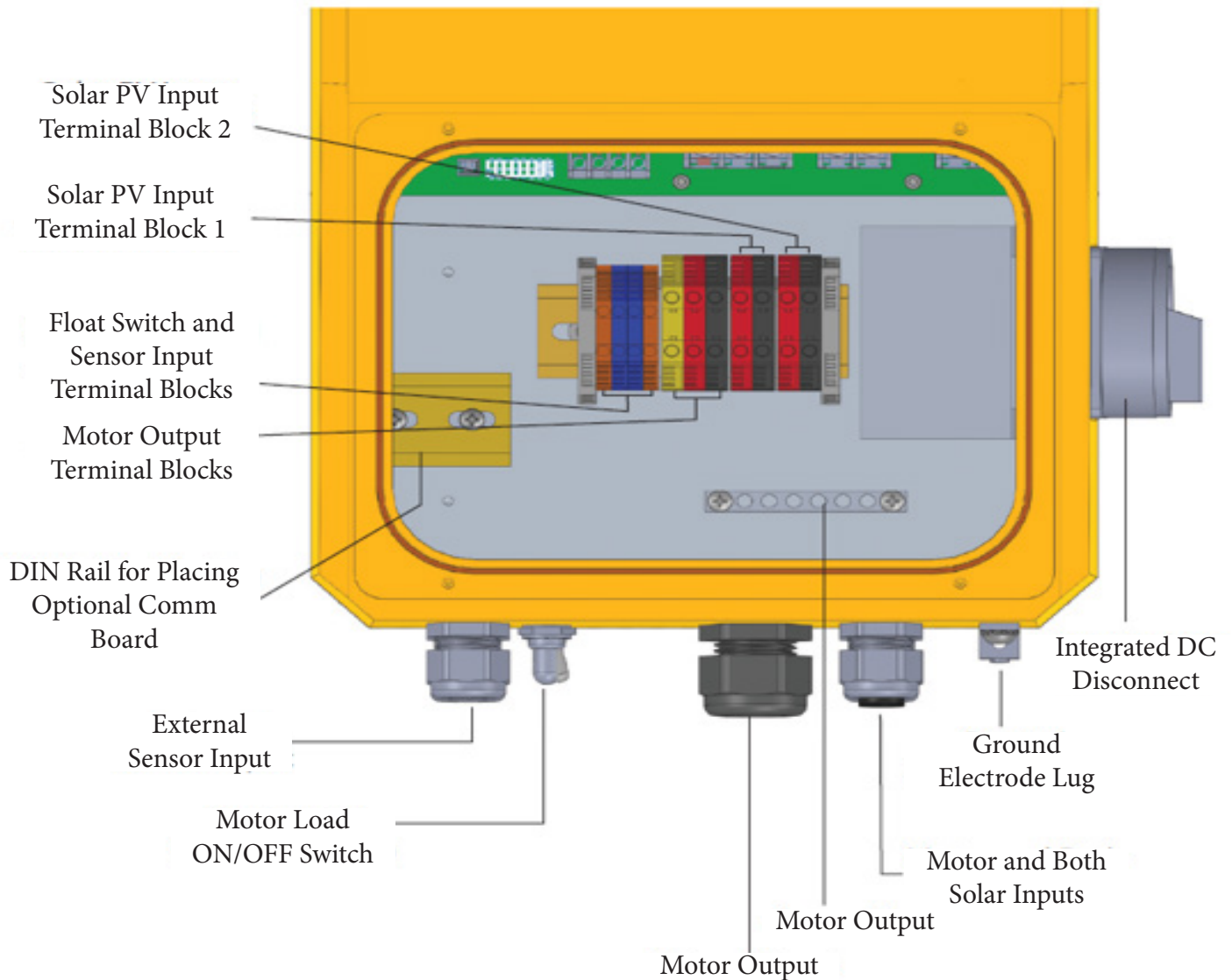

Installation Requirements

The PicoCell must be installed in a shaded location, away from any source of heat and moisture, and in an area free of vegetation. Measures must also be made to protect the unit from damage by unauthorized persons, large animals, overgrowth, flooding, or other harm.

Warning

The PicoCell has voltages capable of causing severe injury or death by electrical shock. It should only be installed and serviced by Kasco Marine authorized dealers and installers. Integral solid-state short circuit protection does not provide branch circuit protection. Branch circuit protection must be provided in accordance with the National Electrical Code and any additional local codes.

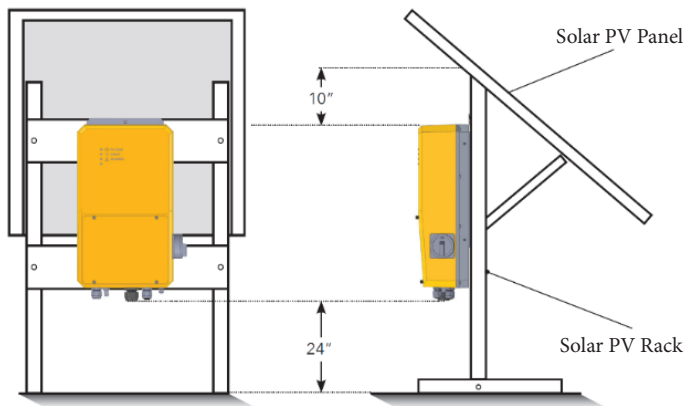

- Contact your Kasco Marine Dealer for any service or warranty claims.
- NEC codes take precedence over suggestions in this manual.

The PicoCell should be mounted at least 2 feet above the ground when possible. A minimum of 10 inches of clearance above the PicoCell is required for internal access. There must be no obstruction of air flow to the heatsink.

The controller should be installed and inspected by technically qualified personnel, and if the controller is not installed in compliance with national and local electrical codes and Kasco Marine recommendations, the controller can be damaged and fail to operate.

A typical installation on a solar panel structure

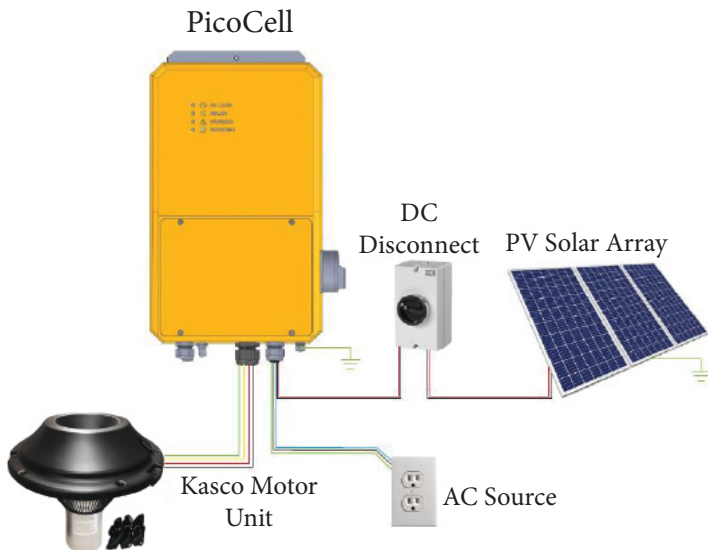

All electrical installations must be carried out in accordance with local standards and the National Electrical Code.

Conductor rated current, temperatures, operating conditions and its power loss must be made in accordance with local standards and the National Electrical Code.

Mounting Instructions

Step 1

Secure the back bracket to the support surface by inserting four screws (not included) through the 4 holes in the back bracket.

Step 2

Make sure all 4 set screws are used to hang the PicoCell onto the back bracket.

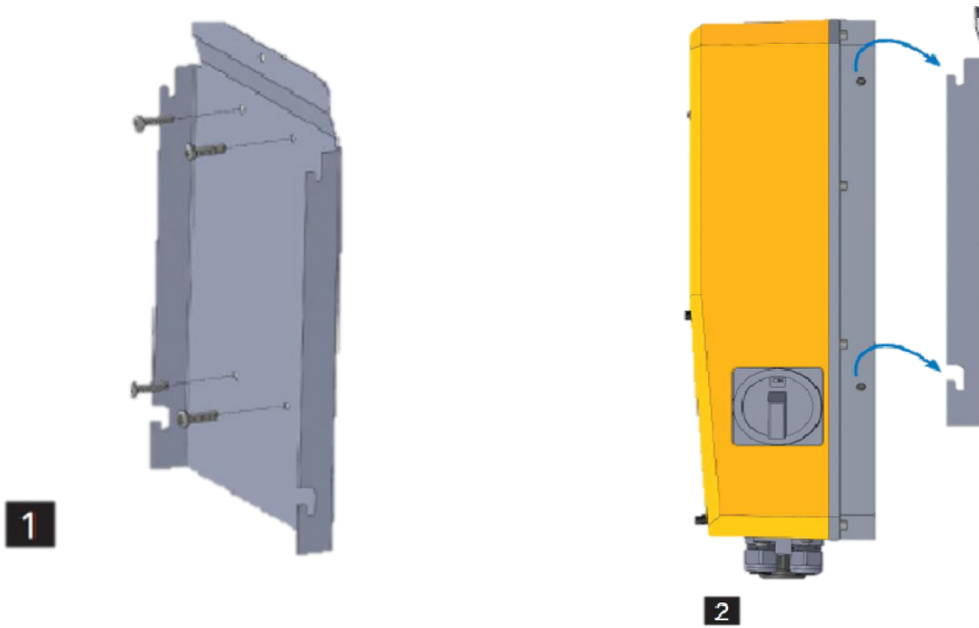

Step 3

Once the PicoCell is in place on the back bracket, screw in the shoulder bolt to secure the unit to the bracket.

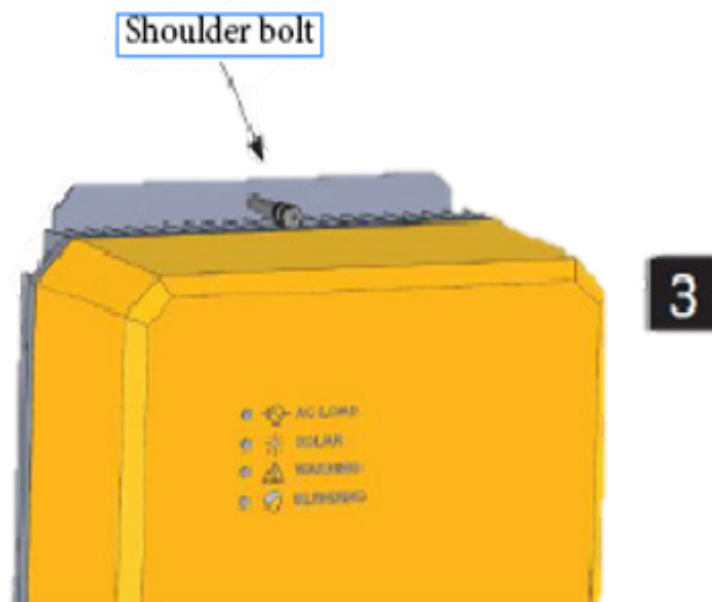

Wiring Instructions

Installation Requirements:

- All electrical installations must be carried out in accordance with local standards and the National Electrical Code.
- Conductor rated current, temperatures, operating conditions and its power loss must be made in accordance with local standards and the National Electrical Code.

Single phase 2-wire motors should be connected to Phase A and C.

Startup:

1. Make sure that the ON/OFF toggle switch is in the OFF position.
2. While the PicoCell is still de-energized, configure the DIP switches per the Kasco product that will be connected. (See DIP switch location settings on the next page)
3. Power up the PicoCell from solar panels by switching the solar DC disconnect to the ON position. All LEDs will light up.
4. Once the solar panel source powers up the PicoCell, turn the bottom external motor ON/OFF toggle switch to the ON position to start the motor load. The PicoCell will check its motor connections using built-in open and short circuit protections. If one of the motor leads is not connected or if there is a short in the motor connections, the PicoCell will show a warning message using indication LEDs. Otherwise, it will start the motor load.

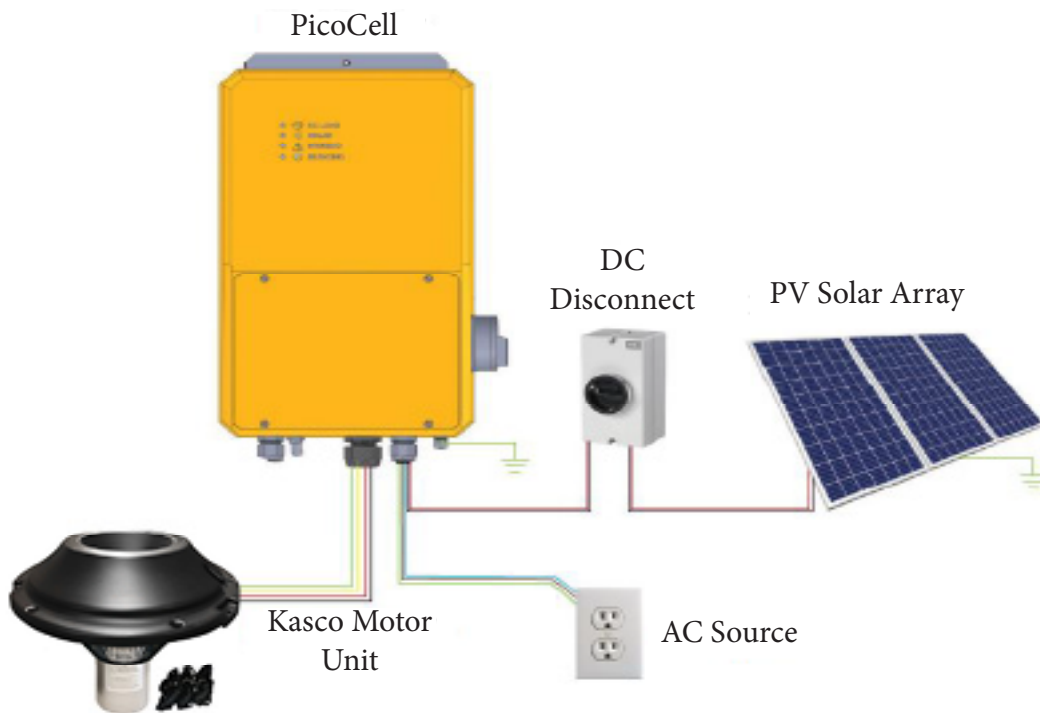

Wiring Instructions

Warning

Do not ground the positive or negative leads of the solar panels. Only ground the mounting frames of the solar panels.

Never run the PicoCell controller when the AC pump is not connected. It might cause damage to the controller.

If an installed 3-phase pump does not start pumping water, switch the positions of any two of the three motor wires. It will change the direction of rotation and it should start pumping water.

PicoCell DIP Switch Settings

Single phase 2-wire motors should be connected to Phase A and C.

Warning

Do not modify DIP switch settings until power has been turned off and after 90 seconds have passed for internal voltages to discharge below voltage of 50Vdc. Power must be removed for DIP switch set-

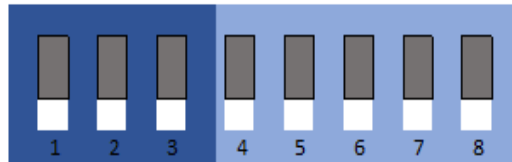

<u>Kasco Product</u>	<u>HP, Voltage, Phase</u>	<u>DIP Switch #1</u>	<u>DIP Switch #2</u>	<u>DIP Switch #3</u>	<u>DIP Switch #4</u>	<u>DIP Switch #5</u>	<u>DIP Switch #6</u>	<u>DIP Switch #7</u>	<u>DIP Switch #8</u>
2400AF	1/2, 120v, 1	Up	Up	Down	Down	Down	Up	Up	Down
2400VFX	1/2, 120v, 1	Up	Up	Down	Down	Down	Up	Up	Down
3400AF	3/4, 120v, 1	Up	Up	Down	Down	Down	Up	Down	Down
3400VFX	3/4, 120v, 1	Up	Up	Down	Down	Down	Up	Down	Down
3400JF	3/4, 120v, 1	Up	Up	Down	Down	Down	Up	Down	Down
4400HAF	1, 240v, 1	Down	Up	Down	Down	Down	Up	Up	Down
4400HVFX	1, 240v, 1	Down	Up	Down	Down	Down	Up	Up	Down
4400HJF	1, 240v, 1	Down	Up	Down	Down	Down	Up	Up	Down
2.3AF	2, 230v, 3	Down	Down	Down	Down	Down	Up	Up	Down
2.3VFX	2, 230v, 3	Down	Down	Down	Down	Down	Down	Up	Down
2.3JF	2, 230v, 3	Down	Down	Down	Down	Down	Down	Up	Down

Operations

If the motor is properly connected, the PicoCell will begin the startup procedure, the green AC LOAD LED (below) will have solid green light, and the motor will start running.

The PicoCell has built-in overload protection, so if a connected motor has a power level higher than the PicoCell limitations, it first slows down and tries to run the motor at a lower power level. If the motor power continues to be outside the power range of the PicoCell, it will shut off the motor operation. If there is not enough solar power, the unit's SOLAR LED light will blink yellow, as shown below. This usually happens in the early morning or late evening, or during overcast weather. The PicoCell controller will try to start the motor once every minute. Each attempt will be indicated by the blinking green LED. If there is not enough solar production from the solar panels, the yellow LED will start blinking again.

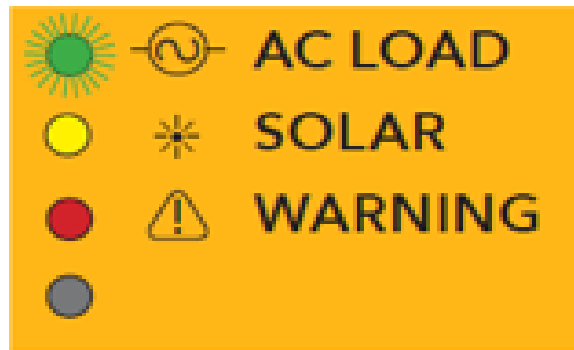

AC LOAD LED

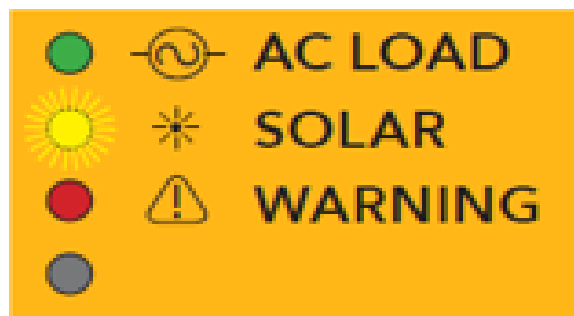

SOLAR LED

Troubleshooting

To stop the PicoCell's operation, the ON/OFF toggle switch on the bottom of the unit should be used. Once in the OFF position, the PicoCell will automatically stop the motor's operation.

The WARNING LED will be solid red if the temperature of the PicoCell rises above 176°F, at which point the PicoCell will stop operating and wait until the temperature drops. This can happen if the unit is exposed to direct sunlight, which should be avoided.

If the PicoCell gets too hot during normal operation, it will switch to Power Deration mode, limiting the maximum power that is transferred to the motor load. During that time, the AC LOAD LED will be solid green and the WARNING LED will be solid red. If the unit cools down to a regular operating temperature, it will automatically continue operation without the thermal deration. If the temperature of the PicoCell continues to increase, it will eventually stop operating, at which point the WARNING LED will be solid red.

There are four LED lights on the PicoBlender. Three of these are indicator lights and their definitions are listed below.

AC LOAD	SOLAR	WARNING	MODE
ON	ON	ON	- Unit is OFF
FLASHING	OFF	OFF	- Startup
ON	OFF	OFF	- Running
OFF	FLASHING	OFF	- Standby
OFF	OFF	FLASHING	- Float switch
OFF	OFF	ON	- Over temperature
ON	OFF	ON	- Power deration
FLASHING	OFF	FLASHING	- Over current
OFF	FLASHING	FLASHING	- Short/Open circuit

OFF Mode	PicoBlender toggle switch is in the OFF position.
Startup Mode	PicoBlender is in the process of starting the motor pump.
Running Mode	PicoBlender is running the motor pump.
Standby Mode	There is not enough power from the solar PV panels for PicoBlender to start the motor.
Over Temperature Mode	PicoBlender stops operation when the temperature inside the unit exceeds 80°C/176°F.
Power Deration Mode	PicoBlender still operates but with reduced power throughput due to increased operating temperature, or if load is connected with current higher than Over Current Protection DIP Switches 6 and 7.
Over Current Mode	PicoBlender stops operation when it detects high current on the motor terminals. This can also be due to a short circuit event if the unit is mis-wired. Requires manual restart by cycling power to the unit.
Open Circuit Mode	PicoBlender will not start operation if the motor wiring does not align with DIP switch configuration.