

# INSTRUCTIONS FOR REMOTE MANIFOLD INSTALLATION

## RobustAire Medium and Large Cabinet Systems

RobustAire™ systems with the optional remote manifold have a single air line exiting each compressor. Follow the instructions below to assemble and install the remote manifolds.

### Suggested Tools & Supplies

- 1" Sch. 40 CPVC pipe (amount varies)
- Sch. 40 PVC pipe Couplings (see below)
- PVC primer and glue
- PVC pipe cutter
- Shovel or other trenching tools
- Pliers (for hose clamp installation)
- Thread sealant
- Valve box (included)

### Required Pipe & Fittings

Item	Qty	Pipe fittings	Size / Type
A	2*	PVC straight adapter	1 NPT socket connector
B	2*	PVC union	1 socket connect (female)
C	2	PVC 90-degree elbow connector	1 socket connect
		Pipe	Length
D	1	1" Schedule 40 CPVC pipe, cut	at least .75"
E	1	1" Schedule 40 flexible PVC pipe	at least 8.25"
F	1	1" Schedule 40 CPVC pipe, cut	determined by installer

\*Included parts

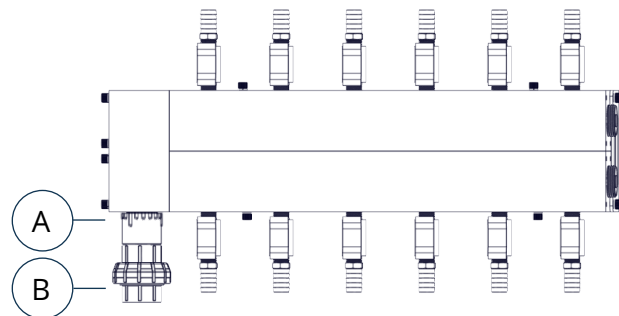
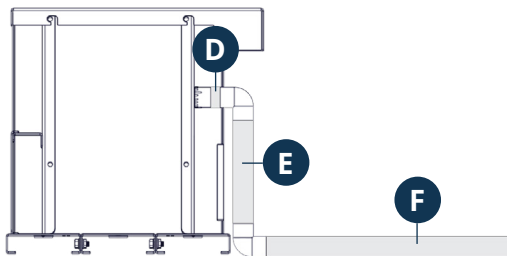
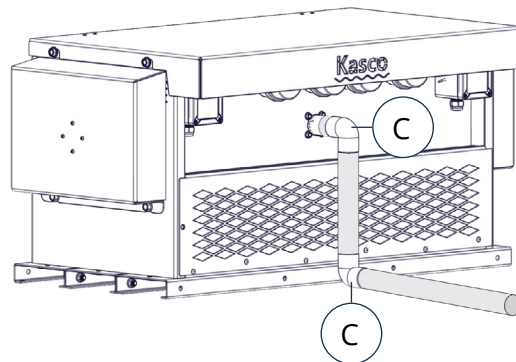
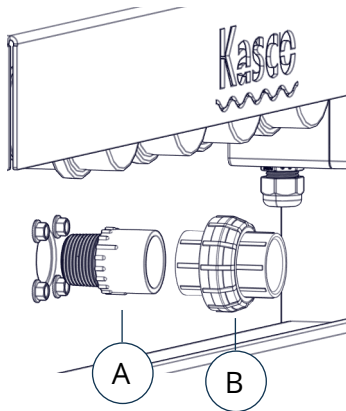

Remote manifold

# REMOTE MANIFOLD INSTALLATION

You will need to excavate a trench 6" to 8" deep to bury the CPVC air line. Start by determining the path of the trench from the RobustAire™ system to an area near the shore. The path should be as straight as possible, with a gentle downward slope towards the water.

For two or three station valve manifolds, excavate an area large enough to bury the valve box. Add crushed rock to the bottom of the area to allow for necessary drainage.

Be sure that the area of excavation does not require tight bends in the tubing. Allow a 6" radius for any bend.

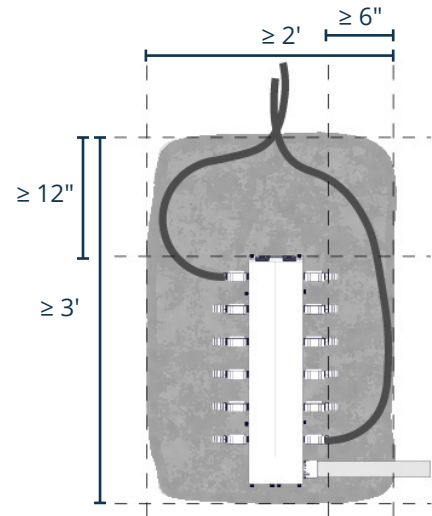
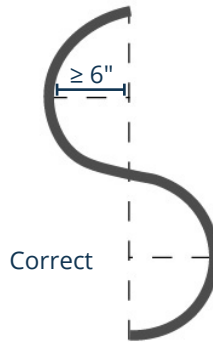
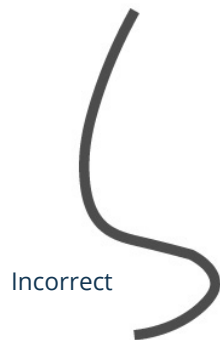

To change the configuration of the manifold, remove the hardware (and pipe plugs) as necessary. You may need to move the pipe plugs for different manifold configurations.

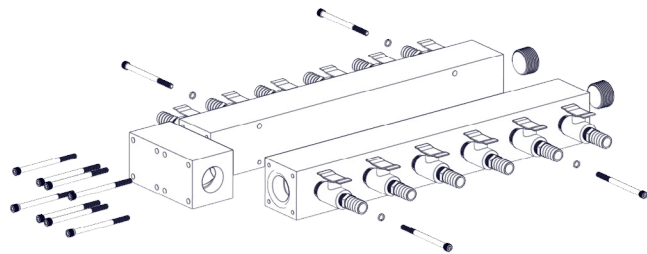

**CAUTION:** In climates where the ground freezes, be sure there are no high or low spots in the CPVC air line. Condensation in the air line may freeze and block the flow of air to diffusers and/or damage compressors.

Medium and Large Cabinet systems require a single trench to and from the manifold.

Connect the brass barb fitting to the PVC adapter, applying thread sealant to male threads on PVC adapter. Connect the barb fitting to the rubber compressor hose lead and secure with a clamp. Connect the PVC adapter and PVC pipe with primer and glue. Add pipe sections as needed to reach the remote manifold.

Prime and glue the manifold assembly to the PVC pipe supplying the compressor. Install 5/8" barb fittings to each diffuser. Apply thread sealant to the male threads of the barb fittings. Attach the tubing to each barb fitting and secure with a hose clamp.

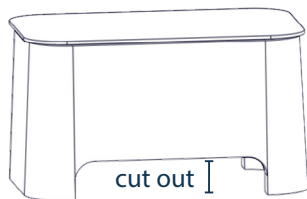

Place the included valve box over the manifold assembly and fill around the box and the entire length of the trench with the excavated dirt. The lid of the valve box should be flush with the ground. You may need to cut out clearance for the tubing to exit the box.

Following installation of systems with multiple diffusers, use the valves to balance flow to each diffuser.