

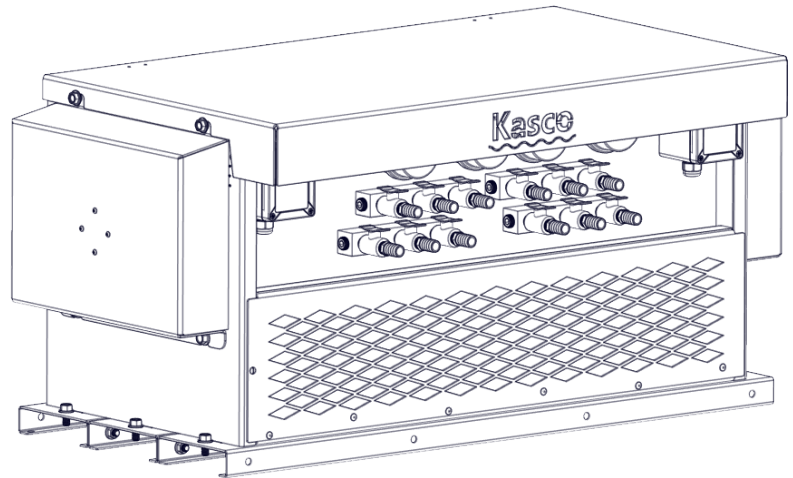

MOVING WATER FORWARD, SINCE 1968



RobustAire™ 50HZ LARGE CABINET DIFFUSED AERATION SYSTEM

Installation & Operation Manual

Document number 774118
Document version 2024.1.0

800 Deere Rd. Prescott, WI 54021 | 715.262.4488 | support@kascomarine.com | kascomarine.com

TABLE OF CONTENTS

Safety First.....	2
Unit Specifications.....	2
Diffuser Installation.....	3
Large cabinet installation	4
Startup Procedure	5
Winter Operation.....	5
Filter Maintenance.....	6
General Maintenance.....	7
Troubleshooting.....	7
Warranty	8
Other Repairs	9
Repair Contact Form	10

QUESTIONS?



715.262.4488



kascomarine.com | support@kascomarine.com

SAFETY FIRST

IMPORTANT: PLEASE READ THIS MANUAL AND SAVE FOR FUTURE REFERENCE

WARNINGS:



Electrical Shock Hazard

- Use caution when dealing with any electrical equipment.
- Use caution around water.
- All electrical equipment must be Ground fault/leakage current protected. Use of a Ground fault protective device (GFI, RCD, RCBB, or RCBO type device) is required as directed by local and national codes.
- Running the system in conditions below freezing may create open areas of water at the diffuser locations and thin ice in the surrounding area.
- Some areas require warning signs to be posted. The system owner will assume all risks of operating the RobustAire™ system during winter months. Check your local laws and ordinances.
- Do not use boats that tip easily, such as canoes, for installation. Follow all boating safety rules and regulations, including wearing a PFD (Personal Flotation Device).
- Consult a qualified electrician for electrical installation.

Hard-wire the leads into 220V service or install an appropriate plug.

Wiring Connections

Brown —————> Black
Blue —————> White
Green w/ stripe —————> Green

NOTE  Electrical wiring color codes may vary by country/region. Check local codes before making connections.

UNIT SPECIFICATIONS

Model	Compressor	# of Diffusers	Voltage/Phase	Amps
RAE7	KM-120HC (1/2HP, x3)	7	220V / 1	5.25
RAE8	KM-120HC (1/2HP, x3)	8	220V / 1	5.25
RAE9	KM-120HC (1/2HP, x3)	9	220V / 1	5.25
RAE10	KM-120HC (1/2HP, x4)	10	220V / 1	7
RAE11	KM-120HC (1/2HP, x4)	11	220V / 1	7
RAE12	KM-120HC (1/2HP, x4)	12	220V / 1	7

DIFFUSER INSTALLATION

The effectiveness of the RobustAire™ system depends on the location of the diffusers in the pond. Place the RobustAire™ Diffusers equidistant from each other at a depth that is representative for most of the pond. Please contact Kasco with any questions about placement or system operation.

**CAUTION: Do not use boats that tip easily for installation.
Always wear a personal flotation device.**

1. Kasco recommends marking the location of each diffuser at the surface with a buoy.
2. Unroll the SureSink Tubing on shore to remove any twists or knots. Performance will decrease if the tube is not properly uncoiled.
3. Each tubing length is 100 feet. If more than one length of tubing is required to reach a diffuser location, connect any additional tubes according to the SureSink Tubing instructions. Unroll these tubes as you did the first tube. You can load multiple rolls of tubes into a boat and connect them as needed while making your way to the proposed diffuser location. You can also connect any number of 100' lengths together and have someone assist in feeding it from shore. Cut off any excess tubing at the shore before connecting to the compressor.
4. Drop the loose end of the tubing near the compressor cabinet. Allow a few extra feet of tubing to work with so the tube will reach the cabinet after trenching between the shore and the compressor.
5. Drive the boat in reverse to keep tubing clear of the propeller and slowly make your way to the marking buoy, placing the tubing as you go.
6. Once you reach the marked buoy, thread a rope through the two holes of the diffuser base. Pull through until the midpoint of the rope is at the diffuser base.

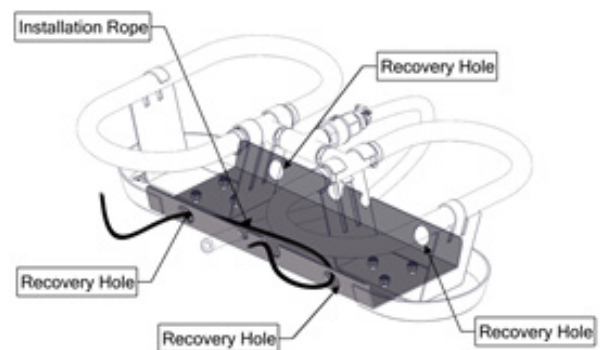
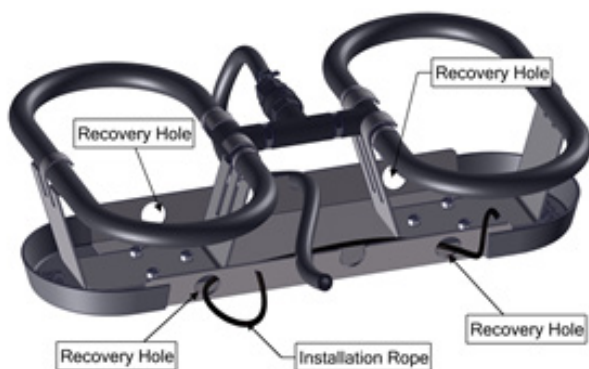

7. While holding the two ends of the rope, gently lower the diffuser assembly into the water.
8. Continue slowly lowering the assembly until it reaches the bottom of the pond. The diffuser will always land right side up.
9. The RobustAire™ Diffuser should now be seated properly on the bottom of the pond. You can remove the rope by pulling on one end. For ease of future maintenance, Kasco recommends leaving the rope looped through diffuser base and tying both ends to a marker buoy or duck decoy. This will allow you to easily locate diffusers and pull them to the surface for maintenance.
10. Repeat the process for additional RobustAire™ Diffuser locations.

LARGE CABINET INSTALLATION

Choose a location far enough from shore to avoid potential flooding. If you use plantings to help hide the cabinet, be sure that both the inlet and the outlet vents are clear, as the compressor requires airflow to prevent overheating. The best foundation options include pea gravel, rubber mulch, and cement.

Place the assembly directly on the ground or attach it to a concrete pad. Use the holes on the bottom flanges to anchor the cabinet.

Place the cabinet adjacent to the electrical service which will power the system. The cabinet has two 1.83m power cords with bare wires. **DO NOT USE EXTENSION CORDS.**

NOTE For remote manifold installation information, see supplementary instruction sheet.

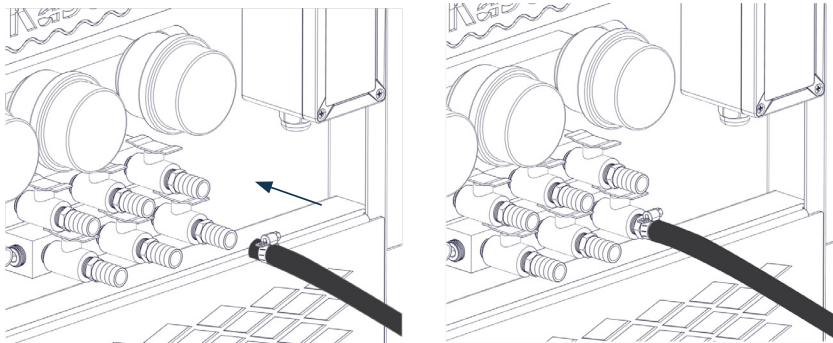
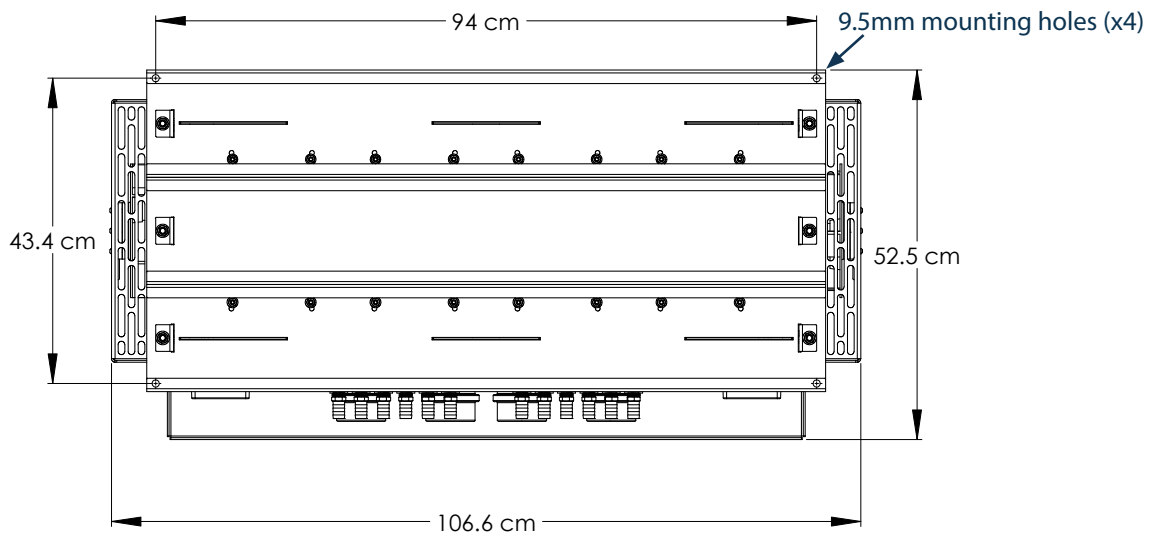
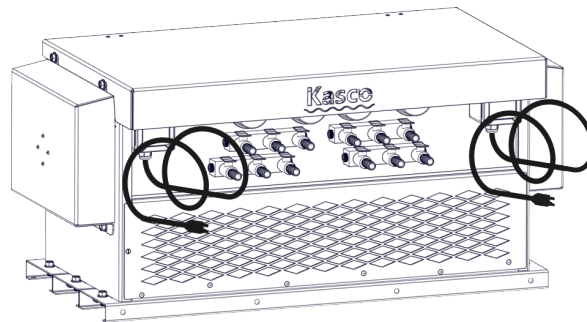

Use the clamps included with the SureSink Tubing kit to complete connections to the compressor.

STARTUP PROCEDURE

IMPORTANT INSTALLATION WARNING

Thermal stratification refers to layering that occurs in some lakes and ponds when warmer water sits on top of colder, denser water toward the lake bottom.

If you install your unit into a body of water that is extremely stratified, use caution when starting the system. In some cases, colder water sitting on the bottom could hold gases that can be harmful to fish. Often, the colder bottom water also contains little or no dissolved oxygen.

A simple test for thermal stratification is to use a thermometer to gradually check for water temperature changes between the top and bottom of the lake or pond. Measure temperature every two feet of depth. Keep the thermometer at each depth long enough to take an accurate temperature reading. Then quickly bring the thermometer to the surface and record the temperature at each depth.

If the colder water (anything 2.22 °C colder than surface) represents more than 30% of the overall volume, start aeration at a slower pace by running the system for short intervals only. For a stratified lake, a suggested start-up interval might include running the system one hour per day for one week and gradually increasing the duration until the system is running continuously. Lakes and ponds react differently to diffused aeration, so exact time frames can be difficult to predict. Sunny days are preferable to cloudy days for system start-up, since photosynthesis will supplement oxygen levels as the water is mixed.

If you have questions about this procedure, please contact your distributor or e-mail Kasco Customer Service at support@kascomarine.com.

WINTER OPERATION



The system owner assumes all risks of operating the RobustAire™ system during winter months.

Operating the RobustAire™ system during the winter or in freezing temperatures may create open areas of water at the diffuser locations. Ice surrounding those areas will be thin. Use extreme caution in the area to avoid injury or fatality from falling into the water. Use signs to indicate the danger to others. Check your local laws and ordinances; some areas require warning signs to be posted.

In climates where temperatures fall below freezing, Kasco recommends insulating the air lines from the compressor cabinet to a minimum of .91m into the water (use low water level for reference). Prevent ice buildup in the lines by using closed cell polyurethane foam to insulate. Ice buildup can block the flow of air to your diffuser and cause damage to your compressor. Insulation should pass through the ice, into the open water below.

Moving the diffusers closer to shore in winter will allow a small area of the shoreline to remain open, preventing winter kill.

FILTER MAINTENANCE

Warning! Product surfaces become very hot during operation. Allow compressor to cool before servicing. Disconnect electrical power before performing maintenance.

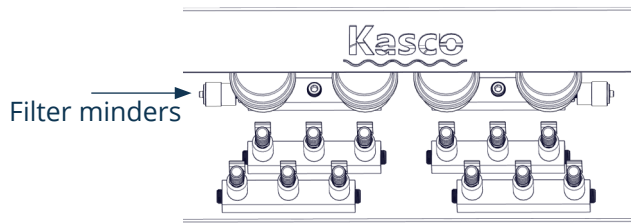

- Check filter monthly.
- Clean or replace intake filter when filter minder shows a red band.
- Reset by pushing the small button on the minder top.
- Failure to maintain clean air filter will lead to excessive heat and premature failure of the compressor.
- Replacement air filter element part number: 771018

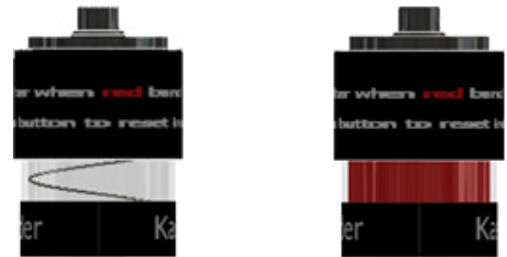

Clean filter
(clear)

Dirty filter
(red)

To access the intake filters, remove the lid of the cabinet. Reach under the lip on the front of the cabinet and pull the outside edges of the two toggle latches down to loosen.

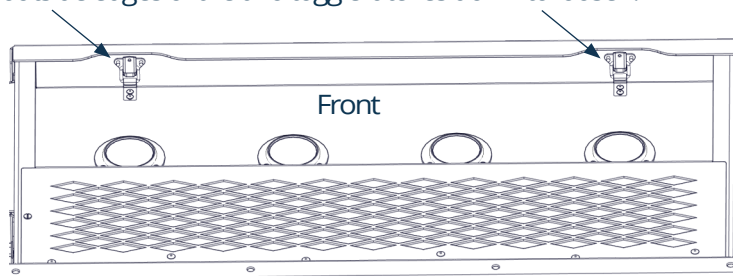

Slide cabinet lid forward.



Lift lid when notches are clear.



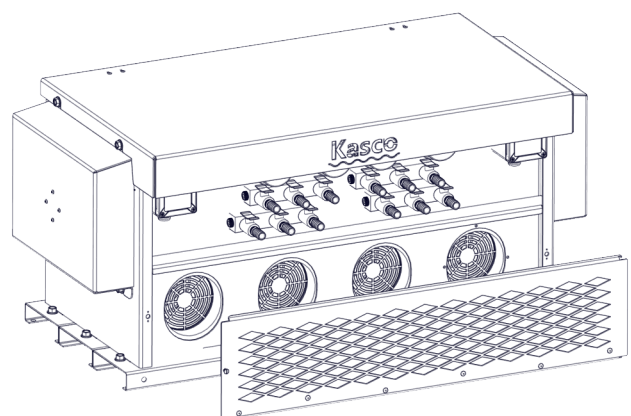
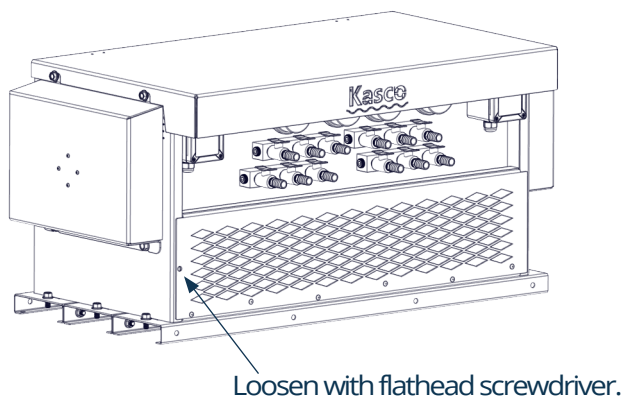

To clean or replace the blue filter, remove the filter housing using a flathead screwdriver.



GENERAL MAINTENANCE

Use the maintenance sticker on the inside of the cabinet lid to track regular maintenance of your RobustAire system.

NOTE  The compressor motor cooling filter (blue) **MUST** be dry when re-installing after cleaning.
 In water bodies greater than 30 feet deep, consider replacing piston cup annually.

Maintenance Action	Frequency
All air filters cleaned	Every 4 months*
Air Filter replaced <ul style="list-style-type: none"> Air Filter Kit = part #774090 <ul style="list-style-type: none"> 3 or 4 compressor systems: 2 kits 	Annually
Compressor motor cooling filter replaced (blue filter) Motor filters kit part numbers: <ul style="list-style-type: none"> For 3 or 4 compressor system = #774089 	Every 24 months
Pressure Gauge reading	Annually
Piston Cup replacement Compressor Maintenance Kit = part #774091 1 required per compressor	Every 24 months**

Desert/dusty locations or locations with daily temperatures exceeding 100 °F or 37 °C:
 * Monthly
 **Annually

TROUBLESHOOTING

“Compressor and fan are not running.”

- Ensure the power cord is connected. Check if the user supplied GFCI circuit is tripped. Reset as necessary

“The fan is running but the compressor is not”

- Inspect the compressor and capacitor wiring and connections.

“The compressor and fan are running, but there are no bubbles coming out of any diffusers”

- Check for leaks in line connections and at the compressor. Check connections for tightness. The compressor may be due for a rebuild.

“The compressor and fan are running. There are bubbles coming out of some diffusers, but not all of them.”

- The valves in the cabinet may need to be balanced. There may be a clogged diffuser that needs to be cleared. The compressor may be due for a rebuild.

“The compressor stops and restarts”

- Ensure the fan is working properly. Capacitor may need replacement.

Please contact Kasco or your distributor if any problems persist.

WARRANTY

Warranty Period

- Diffusers: Lifetime
- Cabinet: Lifetime
 - Exhaust fans: 3 years
- SureSink Tubing: 15 years
- Compressor
 - Motor: 3 years
 - Piston cups and cylinders: 2 years

Kasco® Marine, Inc. warrants this system to be free from defects in material or workmanship under normal use and service. The Kasco Marine, Inc. obligation under this warranty is limited to replacing or repairing free of charge any defective part within the warranty period. The customer shall pay shipping charges for returning the unit to Kasco or an Authorized Repair Center.

THIS WARRANTY IS IN LIEU OF ANY OTHER WARRANTIES, EXPRESSED OR IMPLIED, AND ANY OTHER OBLIGATION OR LIABILITY WHATEVER ON THE PART OF KASCO MARINE, INC. AND IN NO EVENT SHALL KASCO MARINE, INC. BE LIABLE FOR ANY SPECIAL OR CONSEQUENTIAL DAMAGES.

Warranty is void if:

- The system is not maintained properly according to the maintenance recommendations supplied in this manual.
- The system is damaged by unauthorized tampering.

Warranty Claim Procedure

The best method for establishing warranty period is via the original receipt. Also, register the unit online at: www.kascomarine.com. Once the warranty coverage has been established, the unit may be sent to any Kasco Authorized Repair Center for evaluation and repair. Please call Kasco at 715-262-4488 prior to shipping to receive any updated information and/or Repair Form, or call to locate your nearest Authorized Repair Center. You can also email Kasco at support@kascomarine.com.

Please include the repair form received from Kasco or your local distributor with the shipment. If no repair form is available, include your name and physical address for return delivery of the repaired unit and a daytime phone number and/or email address for correspondence regarding the warranty claim. Any expedited shipping method for the return of the unit is at the customer's expense. Kasco will return units repaired under warranty at our expense via ground freight within the continental United States.



Please attach a repair form with the shipment. The repair form must include a name, physical address (for return delivery of the repaired unit), daytime phone number, and an e-mail address for correspondence regarding the warranty claim.

Any expedited shipping method for the return of the unit is at the customer's expense. Kasco will return units repaired under warranty at our expense via ground freight within the continental United States.

OTHER REPAIRS

Most failed equipment can be repaired at substantially lower costs than replacement with new equipment. Please ship according to the instructions provided.

Kasco does estimates on repairs at the request of the customer. The request for an estimate should be included in the letter that accompanies the returned unit and must include a daytime phone number and/or email address. Estimate options are as follows:

- We will contact the customer with a total estimated cost for repairs after we have evaluated the unit but before we perform the work.
- We will repair the unit only if repair costs are under a dollar amount stated by the customer. Example: "Please repair if total is under \$150.00 before shipping charges."

All estimates that are rejected for repair will be destroyed unless otherwise directed by the customer. If the customer would like the unit returned, we will restore the unit as closely as possible to the condition in which we found it and ship at the customer's expense (including shipping and handling charges).

Billing: Kasco accepts Visa and MasterCard credit card payments. Kasco will call for credit card information upon completion of the estimate at the customer's request. All other warranty and repair inquiries should be directed to Kasco at 715-262-4488 or repairs@kascomarine.com

CONTACT US



Kasco Marine
800 Deere Road
Prescott, WI 54021



715.262.4488



kascomarine.com | support@kascomarine.com

REPAIR CONTACT FORM

- Kasco requires that all equipment sent for repair MUST be accompanied by this form and marked to Repairs attention.
- Unit should be cleaned before shipping.
- Kasco is NOT responsible for shipping damage accrued in return shipment.
- It is the responsibility of the customer to ship and pay freight to Kasco.

Kasco Marine
800 Deere Road
Prescott, WI 54021
Attn: Repairs

Note: Contact information should be that of the person or company to contact for repair information.

Company name			
Contact name	First name	Last name	
Address	Street		
	City		
	State		
	ZIP code		
Phone number	Primary	Alternate	
Email address			
Preferred method of contact (circle one)	Phone	Email	
Purchase order number			
Additional product information	Serial Number	Cord Length	
Information for Repair Technician			
Was this unit used in a chemical treatment or wastewater application? (circle one)	Yes	No	
Additional notes			