

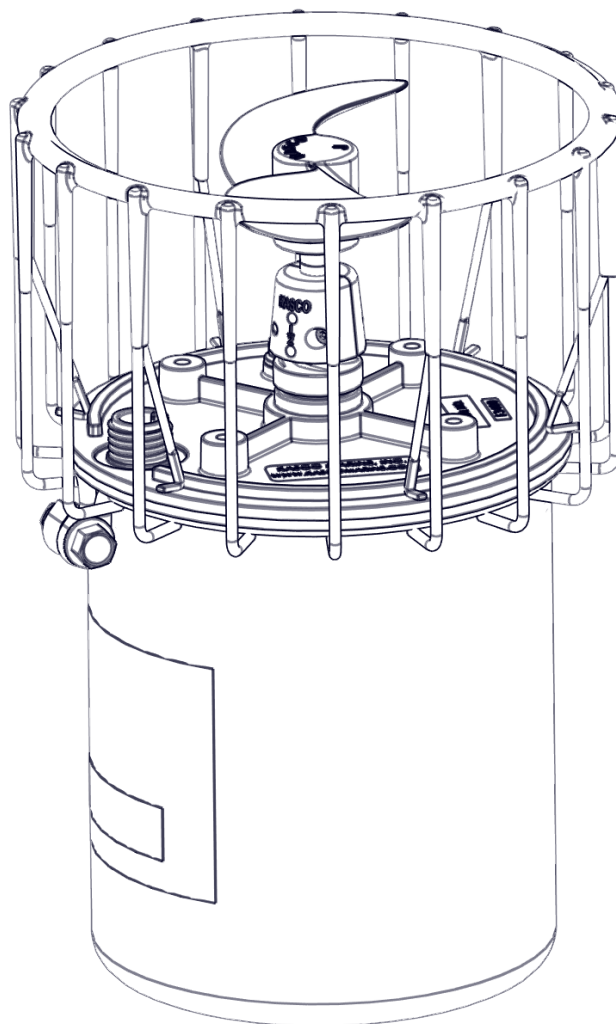

MOVING WATER FORWARD, SINCE 1968

DE-ICER



Operation & Maintenance Manual



3020379
ANSI/UL 778: 2016
Ed.6+R:22Feb2017
CSA C22.2 #108: 2014 Ed.5

Document number 824404
Document version 2025.1.0

TABLE OF CONTENTS

Safety First.....	2
Unit Specifications and Sizing Chart.....	3
General Instructions.....	4
De-icer Installation	5
Maintenance Recommendations.....	8
Troubleshooting Tips.....	9
Replacement Parts	10
Mount Options	11
Control Options.....	11
Warranty	12
Non-Warranty Repairs	13
Repair Contact Form	14

QUESTIONS?



715.262.4488



kascomarine.com | support@kascomarine.com

SAFETY FIRST

IMPORTANT: PLEASE READ THIS MANUAL AND SAVE FOR FUTURE REFERENCE

WARNINGS:



Moving Machinery



Shock Hazard

- Under NO circumstances should anyone enter the water with the electrical equipment connected and/or in operation. It is NEVER recommended to enter the water with the equipment in operation.
- Use caution when dealing with any electrical equipment with moving parts.
- NEVER run the unit out of water. It will damage the seals and create a dangerous situation for the operator.
- Use extreme caution around water, especially cold water, such as in spring, fall, and winter, which poses a hazard in and of itself.
- NEVER lift or drag the unit by the power cord. If you need to pull the unit to the side of the pond, use the ropes or mount to remove it from the water.
- Do not use waders in deep ponds/lakes or ponds/lakes with drop-offs, drastic slopes, or soft bottom material.
- Do not use boats that tip easily for unit installation, such as a canoe, and follow all boating safety rules and regulations, including wearing a PFD (Personal Flotation Device).
- The unit is supplied with an internal grounding conductor. To reduce the risk of electrical shock, be certain that the unit is plugged in/connected to an approved GFCI-protected circuit.
- Means for disconnection must be incorporated in the fixed wiring in accordance with local and national wiring rules.
- Consult a qualified electrician for electrical installation.

UNIT SPECIFICATIONS AND SIZING CHART

Model	Voltage	Operating Amps	Locked Rotor Amps	Thrust (lbs.)
2400D	110-120	5.4	20	31
3400D	110-120	6.6	18	37
3400HD	208-240	3.1	9	37
4400D	110-120	9.1	40	42
4400HD	208-240	4.5	20	42

Sizing recommendations based on the following assumptions:

- Unobstructed water.
- 200-acre+ body of water with 200 feet+ water depth.
- Water depth in de-icing area is greater than 4 feet.
- (Size may vary greatly based on a number of local conditions).

Average Low Air Temperature	Orientation	Model		
		2400	3400	4400
20° F to 34° F (-6.6° C to 1° C)	Angled	30' x 100'	35' x 120'	40' x 150'
	Vertical	65'	85'	90'
0° F to 19° F (-17.7° C to -7° C)	Angled	25' x 60'	30' x 80'	35' x 90'
	Vertical	50'	70'	80'
-20° F to -1° F (-29° C to -18.3° C)	Angled	25' x 55'	30' x 75'	35' x 85'
	Vertical	35'	50'	65'
BELOW -20° F (BELOW -29 ° C)	Angled	20' x 40'	25' x 50'	30' x 60'
	Vertical	30'	45'	55'

GENERAL INSTRUCTIONS

Inspect The Shipment

Immediately inspect your Kasco De-icer shipment for any visible damages. Damages should be reported immediately to your carrier and distributor.

Caution Warning

Under NO circumstances should anyone enter the water with the unit in operation. Always operate the unit in the water and keep people and objects clear of the propeller. Do not lift or pull the unit by the electrical cord. Always use extreme caution around electrical equipment and water.

Assembly & Installation

Please refer to the instructions enclosed in this manual. Each is specific for your model and size of de-icer and de-icer accessory.

Warranty

Kasco De-icers are the result of more than 50 years of design and engineering. Kasco products are built to withstand the toughest conditions. Kasco backs each de-icer with a 3-year Warranty. This warranty covers any and all manufacturer defects within 3 years from the date of purchase (see Warranty Policy). Please register your de-icer using [the form available on the Kasco website](#).

Use & Operation

Kasco De-icers are designed and engineered for continuous duty in the harshest environments, such as in marinas or other commercial applications. Following installation, your Kasco De-icer is ready for immediate use. The motor is oil-filled, with ball bearings submerged in oil and equipped with a thermal overload protection and an automatic reset. No further lubrication is necessary. It is extremely important that the installer makes sure sufficient and proper voltage is available to the unit's motor.

The sacrificial anode located on the shaft below the propeller must be in good condition in order to prevent corrosion damage to the unit. The anode must be inspected periodically and replaced if it shows significant deterioration.

Make sure to keep the motor housing clean from hard water deposits and/or algae.

If the de-icer has been stored or exposed to cold for an extended period without running, it may take a minute for the prop to get to full speed once power is supplied.

The de-icer is also completely assembled. You do not need bolts, screws, nails, or brackets, unless you purchased an optional mounting device. All you have to do is suspend it in as little as two (2) feet of water and plug it into a properly grounded and GFI-protected outlet of the correct size for your installation.

Kasco De-icers are lightweight, energy efficient, and easy to install and operate. We strive to produce products that exceed customer expectations. We hope you enjoy your Kasco De-icer.



NOTE Under certain conditions, no de-icer can prevent damage from ice movement caused by wind or current, or from extremely cold weather causing ice to form all the way to the bottom or in cases where the bottom water temperature is the same as the water nearest to the ice. De-icing can also become less effective in extremely shallow conditions.

DE-ICER INSTALLATION

Kasco offers two basic options for de-icer installation: vertical rope suspension or dock mounting. Different de-icing objectives may require different mounting and installation approaches.

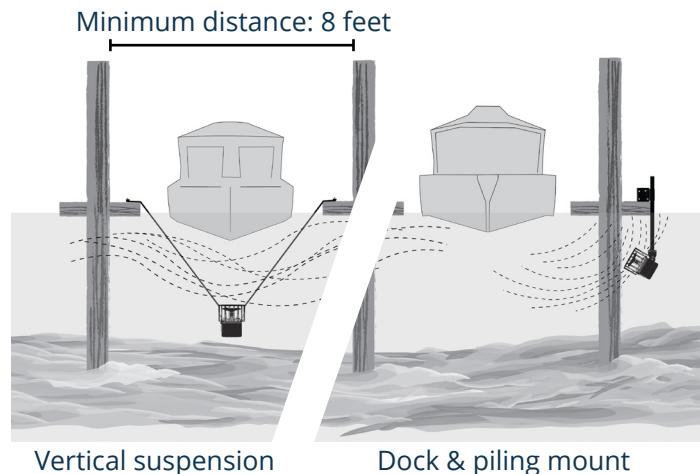

1. Determine Your De-icing Objectives

Placing a de-icer depends on your de-icing objectives. If ice expansion pressure is your concern, you may find it easier to have an open-water buffer between your dock or structure and the expanding ice pack.

If ice lifting or a combination of lifting/expansion is your concern, you may wish to keep your dock, structure, or boat area completely free of ice. These objectives are different and may require different installations.

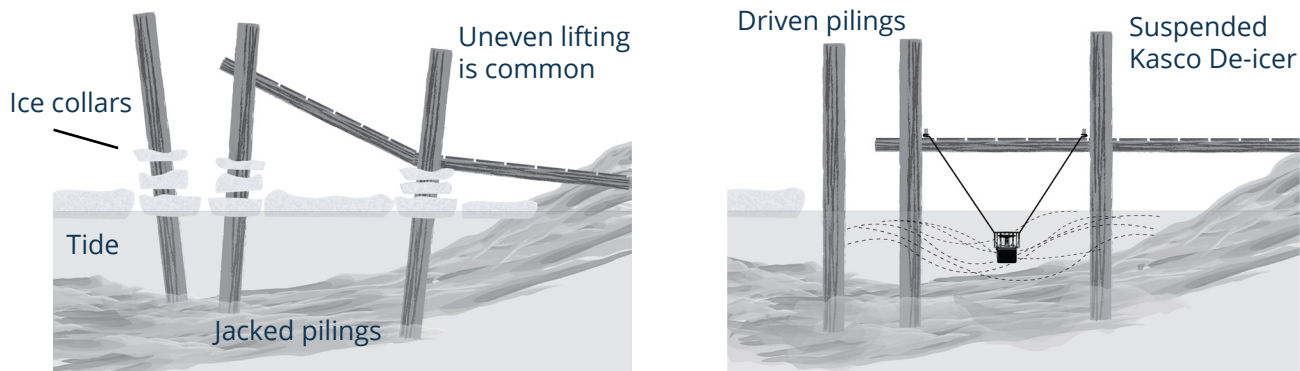

2. Calculate the Optimal Depth for Your De-icer

Determine the best location(s) to install. A de-icer draws warmer, denser water from the bottom (0 °C / 40 °F is approximately water's densest point) and circulates it upward to the surface. Around docks and boats, water is usually fairly shallow, so look for somewhat deeper water to install your de-icer. However, if your de-icer is installed too deep, the rising warmer water will not effectively spread at the surface, thereby reducing the de-icing effect.

NOTE A good guide is to place the de-icer 4-6 feet deep for vertical installation and slightly shallower for angled operation, but at least 1 foot off the bottom to prevent clogging from debris. In colder climates, circulating warmer water is more important than surface circulation, so you may wish to install your de-icer deeper than the above guidelines. De-icers generally work in shallower water but are less effective, and due to the constraints of the environment, you may have to settle for a shallower installation. We recommend that you experiment with more than one possible location for the best installation results.

DE-ICER INSTALLATION (CONT.)

3. Consider Obstructions and Water Movement in the Area

When you have determined both your de-icing objectives and the best installation points for your application, it is time to consider any obstructions, such as structures or boats, that could affect the flow of warmer water at the surface. Any obstruction at the surface of the water may slow or stop the flow of warmer water moved by the de-icer. Additionally, natural currents, such as in a river, will tend to move your de-iced water downstream.

Once you have determined your external constraints, you can choose your installation point(s). Some useful tricks you may wish to consider are:

- De-ice from the upstream side and let the current help rather than hinder.
- Boats are designed to allow water to flow from the bow to the stern with the least resistance. It is generally easier to de-ice a boat by installing the de-icer at or near the bow, angled to push the flow of water from the de-icer toward the stern. Fully protecting a boat often requires more than one de-icer.
- It is generally easier to de-ice shallow water by bringing in the warmer water from a deeper area. Angle your de-icer from the deeper water toward the shallow water.
- When using more than one unit, it is better to angle all units in one direction, creating a current rather than installing de-icers in opposing directions.
- In tidal waters, split the difference in water depth so the de-icer is in shallow water at low tide and deep water at high tide. If you are de-icing a boat, it is easier to tie your de-icer to the boat and allow the boat and de-icer to rise and fall with the tide together.

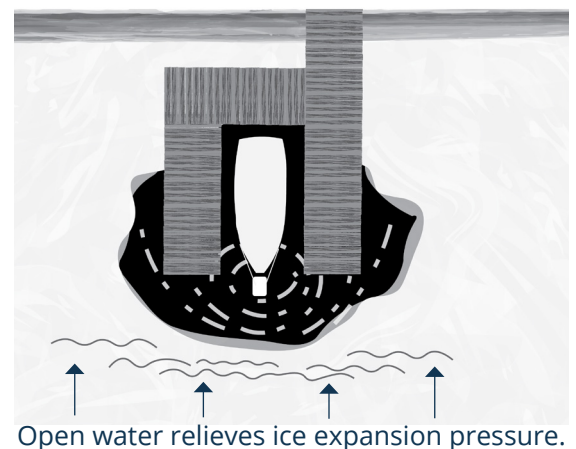
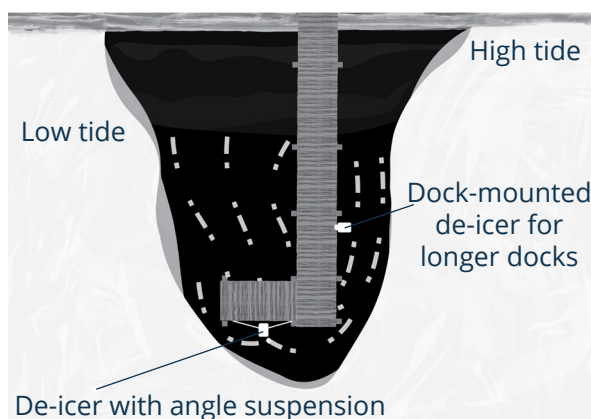
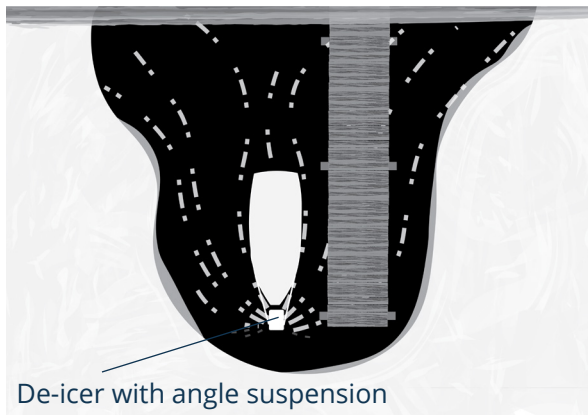

DE-ICER INSTALLATION (CONT.)

4. Angle the Unit in the Water

When installing your Kasco De-icer for suspended operation with the provided ropes or any other suspension line, make sure the lines are spread at least 8 feet apart. The high starting torque of your Kasco De-icer may cause suspension lines that are too close together to twist up and possibly damage the electrical power cord. Tie each rope with a secure knot from the dock piling, cleat, boat, etc., so that the de-icer hangs vertically.

In order to angle your Kasco De-icer while making use of suspension operation, simply change the mounting location of one suspension line. There is no need to remove the knot and splice the rope; simply change the point at which the line suspends the propeller cage by looping the rope around the top circular band across one to four vertical cage wires (more than four not recommended). This will move the support lines off center and make the unit to hang at a slight angle. Once the unit is installed and turned on, your Kasco De-icer will swing up to an angle (the angle is dependent on how many cage wires you move the line), and the de-icer will hold that angle during operation. This allows you to aim the flow of warmer water in the desired direction. See dock mount manual for more information.

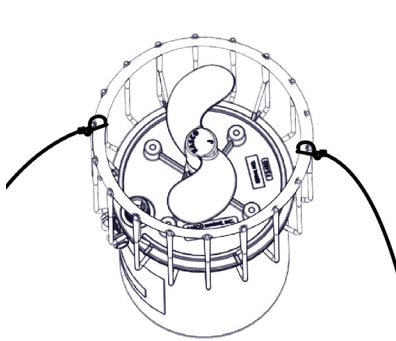

Rope positions as shipped.

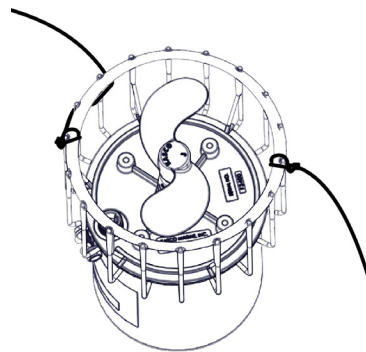

Rope moved up two cage wires.

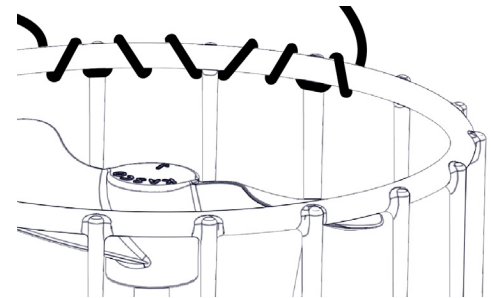

To move the rope up by three or four cage wires, loop it around the cage ring AND around each wire.

5. Power On

Once your de-icer is properly installed and secured, you can now plug the unit into a properly grounded and GFI-protected circuit. If you are using a C-10 Thermostat or C-20 Timer/Thermostat Controller, they can be plugged into the outlet receptacle and the de-icer plugged into the controller.

6. Optional Curtain Installation

If you wish to limit or control the open water area in your installation, you can use a curtain technique to block the flow of water. By draping a canvas tarp as a curtain in the water, you can successfully disrupt the flow of water from the de-icer to follow the appropriate pattern. The canvas can be tied above the water level and weighted at the bottom. An effective weighting method is to fold the tarp in half and lay a chain in the fold. The curtain needs to hang into the water a few feet. This curtain will allow you to protect only the area you need. As always, we recommend that the ice-free area is well marked.

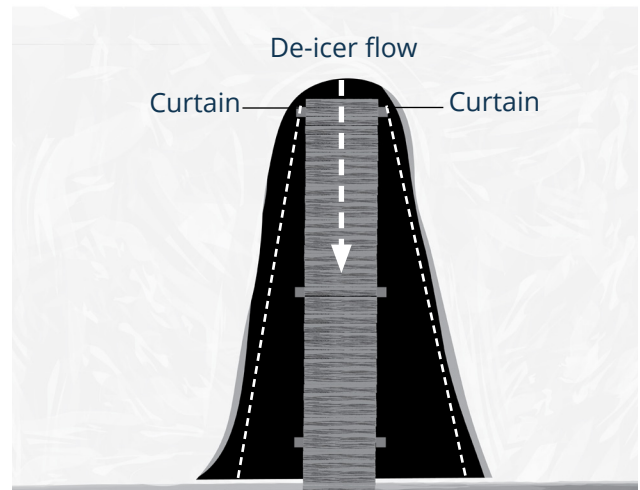

MAINTENANCE RECOMMENDATIONS

Under NO circumstances should anyone enter the water while a de-icer is operating. Turn off and disconnect electrical power prior to any maintenance or servicing. RCD (Residual Current Device) or GFCI are safety features that can also alert you to electrical leaks in the equipment. It is extremely important to test the GFCI upon installation, following each re-installation, and monthly thereafter to ensure proper operation. There should only be one GFCI in a circuit. If you experience repeated or consistent ground fault trips, disconnect the equipment and remove it from the water. The power cord should be inspected for damage, and you should call a Kasco distributor or representative for further instructions. If the supply cord becomes damaged, contact Kasco for replacement instructions or reach out to an authorized service center in order to avoid electrical hazards. Kasco recommends placing an extra serial number sticker on the inside of the control panel cover.

Observation

Operating equipment should be observed on a regular basis (daily, if possible) for any reduction or variation in performance. If you observe a change in performance, the equipment should be disconnected from power and inspected for any material that may have clogged the system or wrapped around the shaft of the motor, especially plastic bags and fishing line. Even though Kasco De-icers are among the most clog-resistant on the market, it is impossible to protect against all items that can clog equipment and still maintain a flow of water. These materials can be very damaging to the equipment under continued operation and must be removed as soon as possible.

ALWAYS DISCONNECT POWER TO THE UNIT BEFORE ATTEMPTING TO REMOVE CLOGS.

Cleaning

Remove equipment from the water at least once per year to clean the exterior of the system, especially the stainless steel motor housing (can). The motor housing is the surface that dissipates heat into the water, and any algae, calcium, etc. buildup will become an insulator that blocks heat transfer. In warmer regions, we recommend removing and cleaning the motor at least two to three times per year depending on conditions. In most cases, a power washer will be sufficient if the unit and algae are still wet. Avoid power-washing the mechanical seal area directly.

Seal And Oil Replacement

This is a sealed motor assembly, and seals will wear out over time (similar to brake pads on a car). Replacement of the seals and a change of oil after three years may add longevity to the operation of the motor, saving you the cost of more expensive repairs.

Sacrificial Anode

A sacrificial anode is supplied on the shaft of all Kasco De-icers for protection of the equipment from corrosion and electrolysis. The anode should be replaced if reduced to half the original size or if white in color. Corrosion from electrolysis is more commonly associated with saltwater or brackish water, but as a matter of precaution, it is important to periodically check the anode in all installations, at least every two to three months.

Seal replacement and all other repair services should be performed by Kasco or a Kasco-trained Authorized Repair Center. Please contact your Kasco distributor or representative for your nearest Authorized Repair Center.

Unit Storage

When storing units during the off-season, it is important to store them with the cage down if they are going to be sitting for long periods of time. Units that sit upright on a shelf for many months, or even years, have a greater likelihood of seals drying out. Storing upside down will ensure oil is lubricating the seals and help prevent drying.

TROUBLESHOOTING TIPS

Below are some helpful troubleshooting tips. If a problem occurs, please double check the assembly and installation instructions as well as the instructions for the control panel. More troubleshooting tips can be found at www.kascomarine.com.

"My de-icer trips a ground fault interrupter."

This is the most common symptom of several possible problems. To correctly diagnose the problem, you will need to collect more information. A Ground Fault Interrupter (GFI) that trips can indicate an electrical service problem, water contamination in the unit and/or cord, bad breaker, control box problems, motor problems, etc.

Try to find out the answers to these questions before you contact Kasco to narrow down the problem:

- How long does it take to trip the breaker?
- Does it always take the same amount of time to trip?
- How many times has it tripped?
- Have there been any electrical problems in the area recently?

"My de-icer seems to run slowly."

This can also be a symptom of several possible problems. There could be an electrical problem where the unit is not getting the proper voltage. This could also indicate a problem with the motor of the unit, which needs to be looked at by an Authorized Repair Center. Check that the unit is receiving the proper voltage, and, if so, contact Kasco for further steps. Note: If the de-icer has been stored or exposed to cold for an extended period without running, it may take some time for the prop to get to full speed once power is supplied.

"My de-icer hums but will not start. When I spin the prop with a stick, it starts up."

This indicates a problem with the starting capacitor. Each Kasco De-icer is equipped with a starting capacitor to get the unit going when it is first plugged in. If it is operating but not spinning and can be started by spinning the prop with a stick, the starting capacitor needs to be replaced by an Authorized Repair Center.

"My de-icer turns itself off and back on without the timer and without tripping the GFI breaker."

Each Kasco unit has a thermal overload built in that will turn the unit off when it overheats. Once the unit has cooled down, it will start back up. If you are noticing these symptoms, the unit should be unplugged immediately because the thermal overload will continue to turn on and off until it burns out and damages the motor. The unit should be unplugged and taken out of the water to find the cause of the problem. The problem could be one of many, such as low water levels, build-up on the unit to prevent heat dissipation, something inhibiting the free rotation of the shaft, etc. If something is caught in the unit or there is a buildup on the unit, remove the debris. If caught early enough, the unit should be fine. Contact a Kasco representative before restarting the unit.

"My de-icer flow seems to fluctuate and/or be less than usual."

This can occur because of a few different reasons. Most of the time, this symptom is caused by the unit being clogged with debris. A mat of weeds, many leaves, plastic bags, etc., can clog up the unit and cause it to be starved of water. If the unit does not have the proper amount of water, the flow or pattern will fluctuate and appear sporadic. If you are seeing these symptoms, unplug the unit and clean away the debris. Another possibility if you notice these symptoms is a chipped or damaged prop that is causing the unit to wobble and not pump properly. When the unit is unplugged, check the prop for damages and replace if damage is found.

"My C-20 does not seem to be working properly"

Most of the time, a C-20 that is not working properly is due to a setup error. The C-20 Time and Temperature Control must have BOTH the timer AND thermostat activated. (The timer must be in an ON position, and the outside air temperature must be lower than the setting on the thermostat.) Keep in mind: the thermostat may take up to 30 minutes to adjust to the outside temperature. Make sure the C-20 is not in direct sunlight, which would heat up the thermostat. If both are activated, the small light in the upper left hand corner of the control box will be lit up. To troubleshoot, you can put the C-20 in the freezer for a couple hours and then test it. If your outdoor temperature is cold enough, you can set up the C-20 and plug a light into it. Watch it throughout the evening to see if and when the light comes on. If all else fails, please contact Kasco for assistance.

REPLACEMENT PARTS

ID	Description	Qty	Part #
A	2400 model propeller	1	240170
A	3400 model propeller	1	340125K
A	4400 model propeller	1	440430
B	Sacrificial anode assembly (1/2" shaft)	1	243475
B	Sacrificial anode assembly (5/8" shaft)	1	840475
C	Cage assembly (includes D & E)	1	993200
D	3/8"-16 x 1-1/4" serrated flange screw	1	840543
E	3/8"-16 serrated flange nut	1	840532

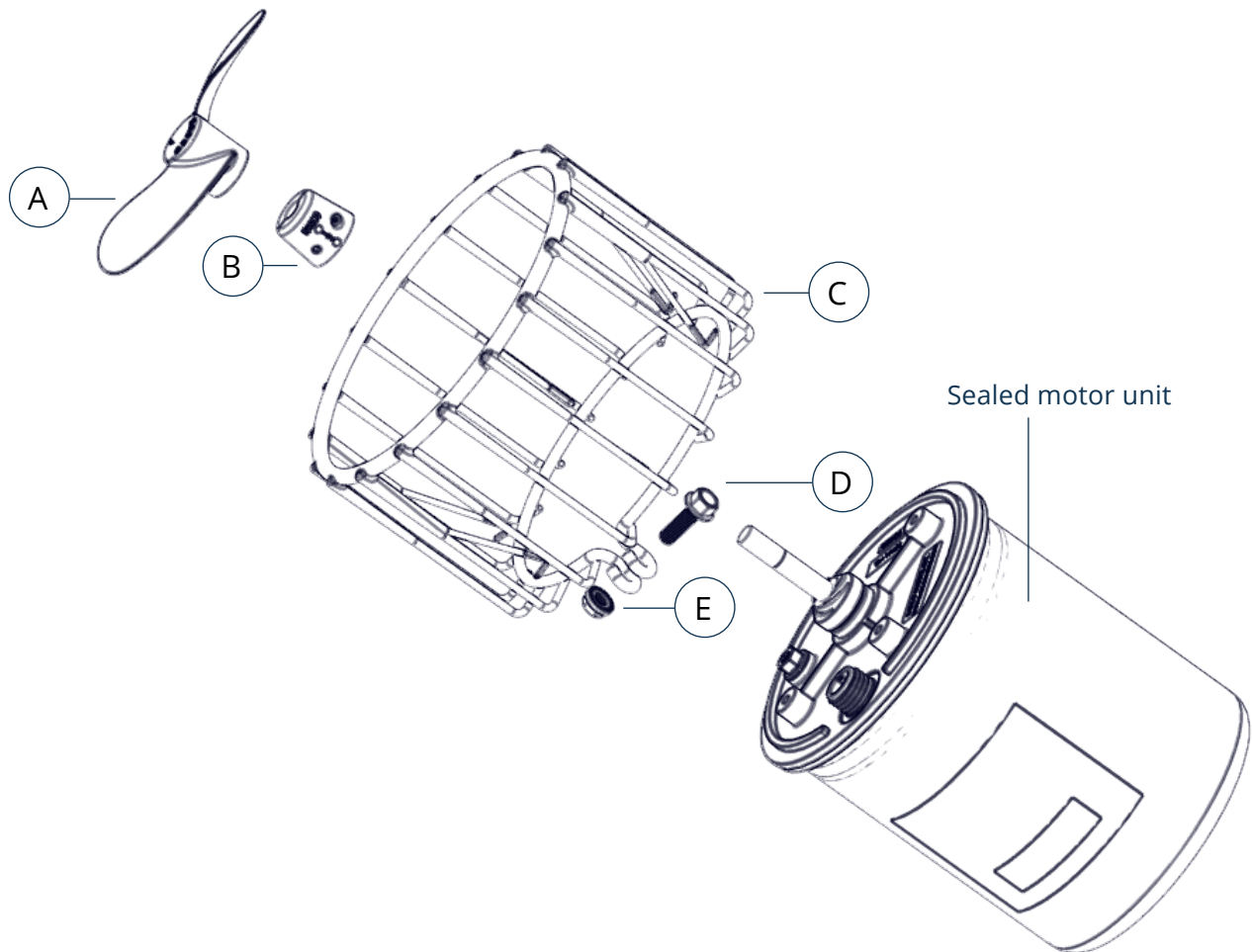

MOUNT OPTIONS

Kasco offers a variety of mounting options to best position a de-icer in any environment, all featuring durable stainless steel. There are also timer and temperature control options.

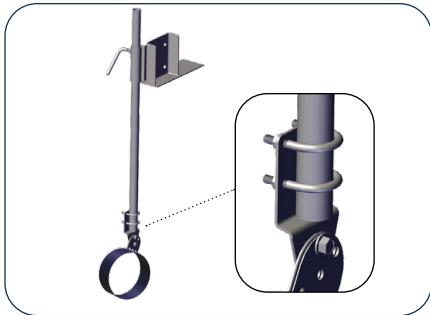

Universal Mount

- For pipe with nominal diameter of 1 inch
- For units up to 1HP
- Kit 243485

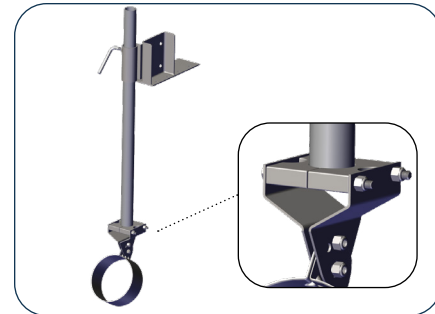

Industrial Mount

- For pipe with nominal diameter of 1.5 inches
- For units up to 1HP and pipe 5 feet long or greater.
- Kit 243484

Easily lower, angle, and position units for proper water movement. Mount to a dock, piling, wall, or other in-water property. Packages include upper and lower mount assemblies; pipe supplied by customer.

Upper Mount Features



The upper mount can be secured horizontally, as shown above, or vertically (left), allowing installation options for a variety of shoreline structures.

Optional: both mounts are available with a Simple Swivel bracket that allows the unit to rotate easily and direct the flow of water (Universal kit 243478, Industrial kit 243479).

CONTROL OPTIONS

C-10 Thermostat Controller

The C-10 Thermostat Controller is an inexpensive way to control the operation of your Kasco De-icer by using air temperature. The C-10 plugs into a standard 120V outlet and allows you to set an air temperature setting to turn the de-icer on when the temperature drops below that setting, allowing you to save money on electrical bills.

C-20 Timer and Temperature Control

Further maximize energy conservation with an added timer feature. The C-20 will only operate your de-icer when both the timer and thermostat are activated.

WARRANTY

Warranty Period: Models 2400D, 3400D, 3400HD, 4400D, 4400HD = 3 years

Kasco® Marine, Inc. warrants this de-icer to be free from defects in material or workmanship (except for the ropes, power cord, and propeller) under normal use and service. The Kasco Marine, Inc. obligation under this warranty is limited to replacing or repairing free of charge any defective part within the warranty period. The customer shall pay shipping charges for returning the unit to Kasco or an Authorized Repair Center.

THIS WARRANTY IS IN LIEU OF ANY OTHER WARRANTIES, EXPRESSED OR IMPLIED, AND ANY OTHER OBLIGATION OR LIABILITY WHATSOEVER ON THE PART OF KASCO MARINE, INC. AND IN NO EVENT SHALL KASCO MARINE, INC. BE LIABLE FOR ANY SPECIAL OR CONSEQUENTIAL DAMAGES.

Warranty is void if:

- The de-icer is not maintained properly according to the Maintenance Recommendations supplied in this manual.
- The de-icer is returned for repair without the power cord or if the unit, control box, or power cord are altered in any way from original shipment. Cuts in the power cord are not covered under warranty.
- The de-icer is not used with a GFCI control box.
- The de-icer is damaged by unauthorized tampering.
- The sacrificial anode around the propeller shaft shows significant deterioration. (The anode must be inspected periodically and replaced if necessary.)

Warranty Claim Procedure: The best method for establishing warranty period is via the original receipt. Also, register the unit online at: www.kascomarine.com. Once the warranty coverage has been established, the unit may be sent to any Kasco Authorized Repair Center for evaluation and repair. Please call Kasco at 715-262-4488 prior to shipping to receive any updated information and/or Repair Form, or call to locate your nearest Authorized Repair Center. You can also email Kasco at support@kascomarine.com.

Please include the repair form received from Kasco or your local distributor with the shipment. If no repair form is available, include your name and physical address for return delivery of the repaired unit and a daytime phone number and/or email address for correspondence regarding the warranty claim. Any expedited shipping method for the return of the unit is at the customer's expense. Kasco will return units repaired under warranty at our expense via ground freight within the continental United States.

Other Repairs

Most failed equipment can be repaired at substantially lower costs than replacement with new equipment. Please ship according to the instructions in the previous section.

Kasco does estimates on repairs at the request of the customer. The request for an estimate should be included in the letter that accompanies the returned unit and must include a daytime phone number and/or email address. Estimate options are as follows:

- We will contact the customer with a total estimated cost for repairs after we have evaluated the unit but before we perform the work.
- We will repair the unit only if repair costs are under a dollar amount stated by the customer. Example: "Please repair if total is under \$150.00 before shipping charges."

All estimates that are rejected for repair will be destroyed unless otherwise directed by the customer. If the customer would like the unit returned, we will restore the unit as closely as possible to the condition in which we found it and ship at the customer's expense (including shipping and handling charges).

Billing: Kasco accepts Visa and MasterCard credit card payments. Kasco will call for credit card information upon completion of the estimate at the customer's request. All other warranty and repair inquiries should be directed to Kasco at 715-262-4488 or repairs@kascomarine.com



Kasco only accepts complete assemblies for warranty repair. We must receive the power cord and all other components with the motor as originally assembled. **THIS DOES NOT INCLUDE CONTROL PANEL, FLOAT, MOUNT, OR OTHER PARTS THAT CAME IN ADDITION TO THE MOTOR ASSEMBLY, UNLESS SPECIFICALLY REQUESTED BY A KASCO REPRESENTATIVE.** Kasco will bill the customer to replace any missing parts necessary for repair.

Please attach a repair form with the shipment. The repair form must include a name, physical address (for return delivery of the repaired unit), daytime phone number, and an e-mail address for correspondence regarding the warranty claim.

Any expedited shipping method for the return of the unit is at the customer's expense. Kasco will return units repaired under warranty at our expense via ground freight within the continental United States.

KASCO PATENTS

To view a full list of Kasco patent and patent-pending information, visit <https://kascomarine.com/patents/>.

CONTACT US



Kasco Marine
800 Deere Road
Prescott, WI 54021



715.262.4488



kascomarine.com | support@kascomarine.com



3020379
ANSI/UL 778: 2016
Ed.6+R:22Feb2017
CSA C22.2 #108: 2014 Ed.5

REPAIR CONTACT FORM

- Kasco requires that all equipment sent for repair MUST be accompanied by this form and marked to Repairs attention.
- Kasco is NOT responsible for shipping damage accrued in return shipment.
- It is the responsibility of the customer to ship and pay freight to Kasco.

Note: Contact information should be that of the person or company to contact for repair information.

Company name		
Contact name	First name	Last name
Address	Street	
	City	
	State	
	ZIP code	
Phone number	Primary	Alternate
Email address		
Preferred method of contact (circle)	Phone	Email
Purchase order number		
Additional product information	Serial Number	Cord Length
Additional notes for repair technician:		

Kasco Marine
 800 Deere Road
 Prescott, WI 54021
 Attn: Repairs