



MOVING WATER FORWARD, SINCE 1968

RGBW40
WaterGlow
STAINLESS STEEL
LIGHTING



**Operation &
Maintenance
Manual**



Document number 884110
Document version 2023.1.2

800 Deere Rd. Prescott, WI 54021 | 715.262.4488 | sales@kascomarine.com | kascomarine.com

TABLE OF CONTENTS

Safety First.....	2
Suggested Tools	2
Parts Included	3
Mounting Instructions.....	4
Wiring Instructions	5
cw4 Controller Operation	7
CW4 Touch-screen Controller.....	8
Arcolis App Control of CW4 Controller	9
LSTA Button Controller	10
Controller Operation	11
Maintenance Recommendations.....	12
Warranty	13
Non-warranty Repairs.....	13
Troubleshooting Tips.....	14
Repair Contact Form	15

QUESTIONS?



715.262.4488



kascomarine.com | sales@kascomarine.com

SAFETY FIRST

Caution should be used when dealing with any electrical and/or moving equipment.

- Under NO CIRCUMSTANCE should anyone enter the water with the electrical equipment plugged in and/or in operation.
- Use extreme caution around water, especially cold water, as in Spring, Fall, and Winter, which poses a hazard in and of itself.
- Kasco RGBW light kits are intended for use with a control panel having a GFCI protected power circuit with dedicated field wiring terminals and disconnect switch.
- They are intended to be mounted on a floating fountain or aerator for use in a natural or man-made body of water to comply with NEC Article 682.
- Kasco light kits have not been evaluated for use in swimming pools, spas, or stationary fountains.
- RGBW kit is 120Vac powered and MUST be connected only to GFCI protected circuit.
- RGBW light fixtures MUST be properly submerged (to mark on housing) to avoid overheating; insufficient submersion or operation out of water will damage fixtures and void warranty.
- NEVER lift or drag the equipment by the power cords. If you need to pull the unit to the side of the pond, use the anchoring ropes.
- Do not use boats that tip easily for light kit or unit installation and follow all boating safety rules and regulations, including wearing a PFD (Personal Flotation Device). Do not use waders in deep ponds/lakes or ponds/lakes with drop-offs, drastic slopes, or soft bottom material.
- For more information regarding control panel instructions, refer to your equipment owner's manual. A control panel must be installed a minimum of 5 feet (3m in Canada) from the body of water unless separated from the body of water by a fence, wall, or other permanent barrier that will make the unit inaccessible to persons in the water. A complete list of control panels can be found in the Accessories section of kascomarine.com.

SUGGESTED TOOLS

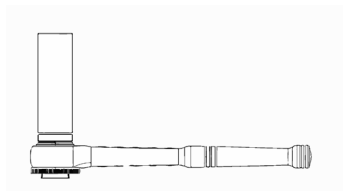

7/16" socket & driver



7/16" combination wrench

PARTS INCLUDED

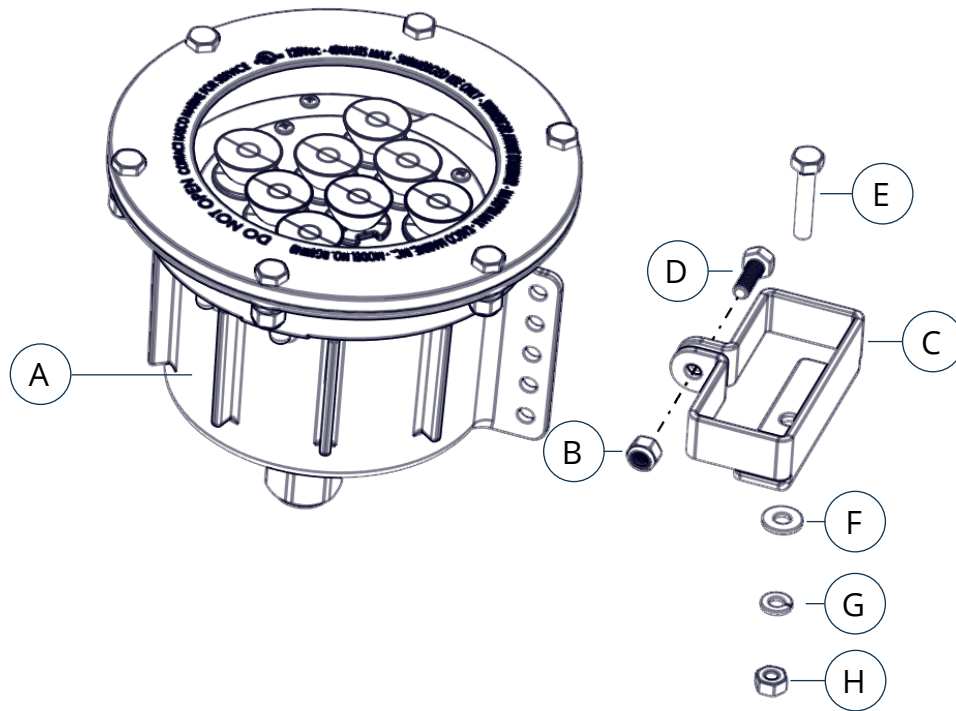

ID	Description	Qty	Part No.
A	RGBW 40 fixture	1	349000
B	1/4"-20 hex locknut	1	451100
C	Bracket, SS LED mounting	1	349035
D	1/4"-20 x 3/4" screw	1	840539
E	1/4"-20 x 1-3/8" screw	1	584692
F	1/4" flat washer	1	258476
G	1/4" lock washer	1	840537
H	1/4"-20 nut	1	840536

MOUNTING INSTRUCTIONS

1. Attach the mounting bracket (C) to the light fixture by using one 1/4"-20 x 3/4" hex screw (D) and one 1/4"-20 lock nut (B). use a 7/16" wrench and socket with driver to tighten. Repeat this step for all fixtures.

- Select a mounting hole on the fixture that will provide proper submergence in the water. Kasco recommends the second hole from the top to fit most applications. Note the marking on the fixture housing for proper water depth.

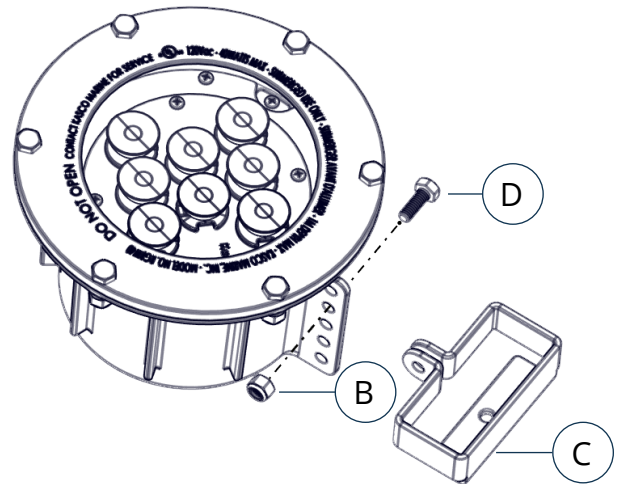

2. Attach the light fixtures to the float using (E) 1/4"-20 x 1-3/8" hex screws, (F) 1/4" flat washer, (G) 1/4" lock washer, & (H) 1/4"-20 hex nut. Washers and nut are installed on bottom side of float mounting tab. Tighten using 7/16" wrench and socket with driver. Repeat for all fixtures. Space the fixtures on the mounting tabs symmetrically with equal spacing.

- Repeat for remaining fixtures, spacing evenly around the float. Adjust angle of lights if desired, being sure that the same angle is used for all fixtures. Cable ties can be used to attach fixture cords to float to decrease play and ensure protection.
- Cable tie the light kit power cord to float. Opposite the fountain power cord for balance and to prevent damage from fountain.

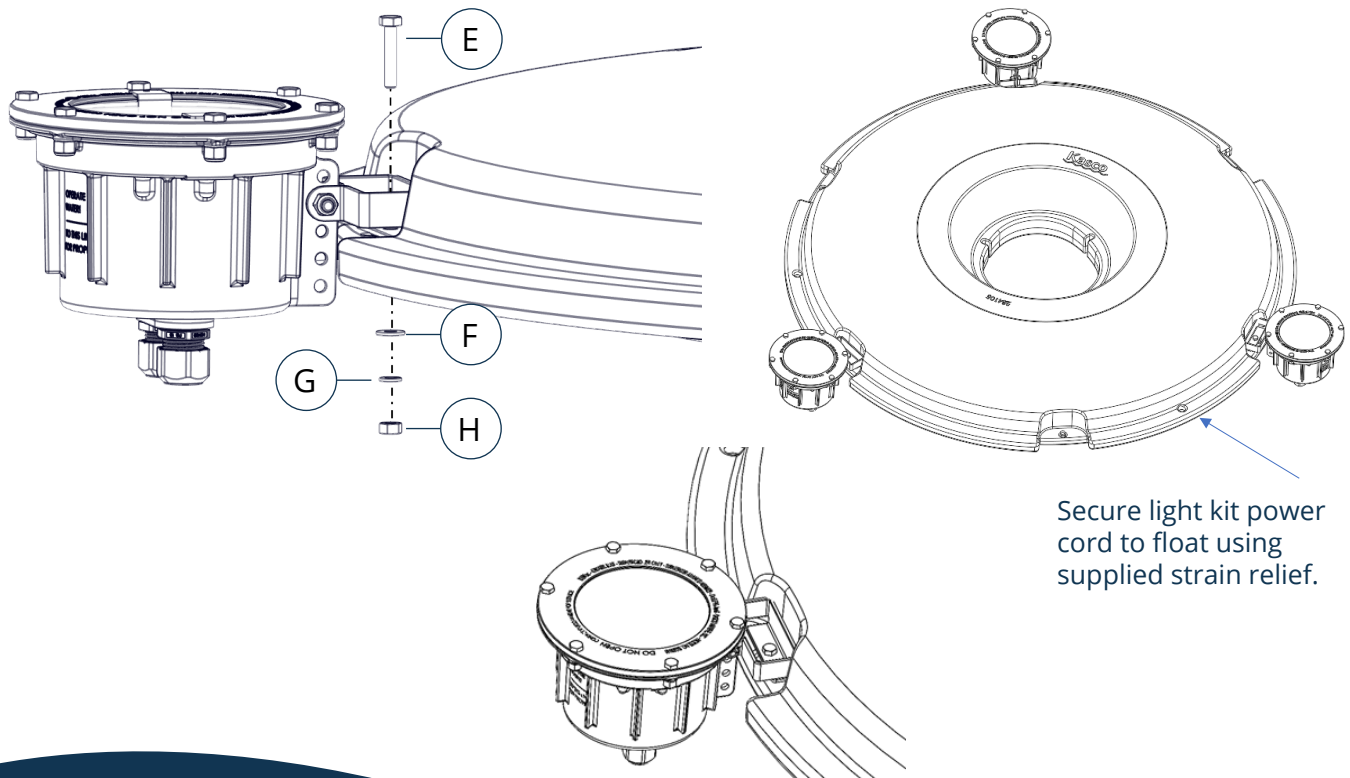

WIRING INSTRUCTIONS

3. Wiring the RGBW control panel to fountain control panel (refer to the RGBW control panel instructions for panel mounting and installation requirements). Connect the RGBW panel power cord to the Kasco Fountain control panel. The RGBW panel has flying leads to connect to the fountain panel terminal blocks used to connect a standard light kit.

- C-85 and C-95 fountain control panels: Connect to terminal #'s. 6, 7, & Ground
- Green lead to Ground, Black lead to #6, & white lead to #7
- 3 phase CF fountain control panels connect to terminal #'s. 3, 4, & Ground lug
- Green to Gnd lug (ground lug), Black lead to #3, & white lead to #4

Refer to Fountain control panel instructions and schematics for detailed operation and connections.

Block Diagram of Light Kit and Control Panels

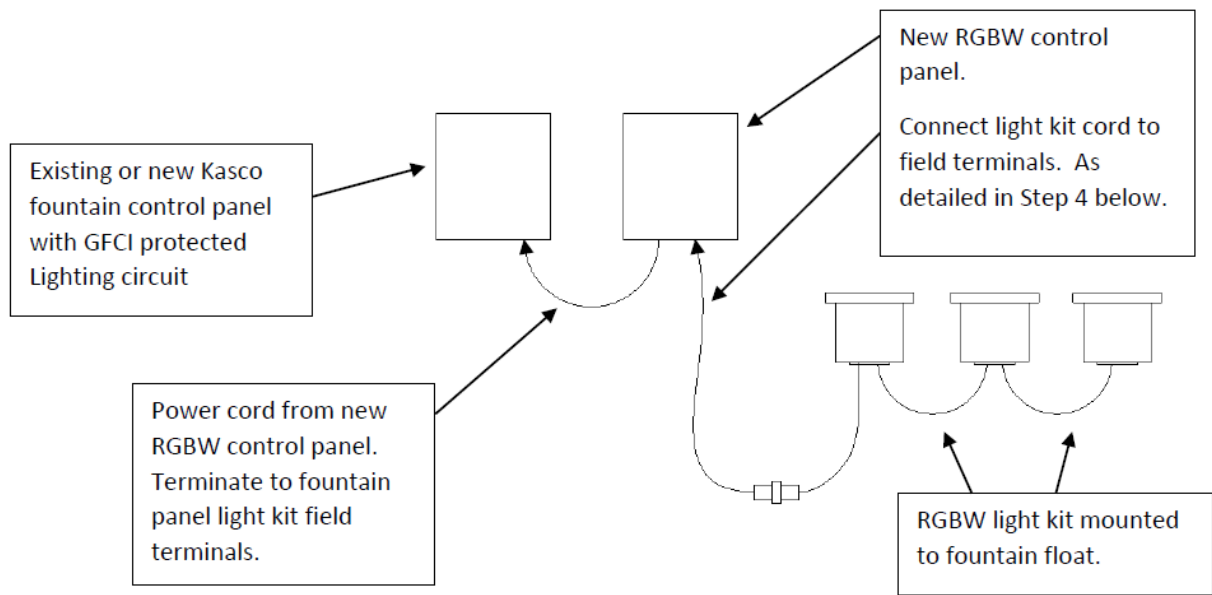

C-85 & C-95 Fountain Control Panel Field Terminal Connections

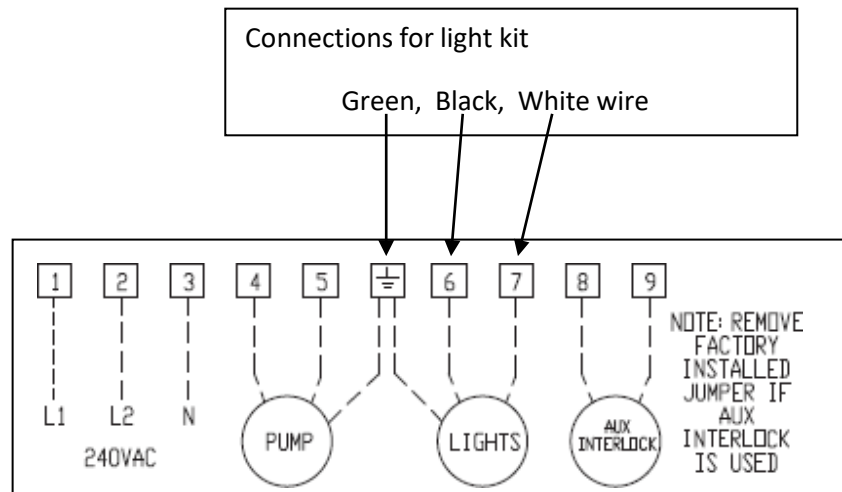

WIRING INSTRUCTIONS (CONT.)

3-Phase Fountain Control Panel Field Terminal Connections

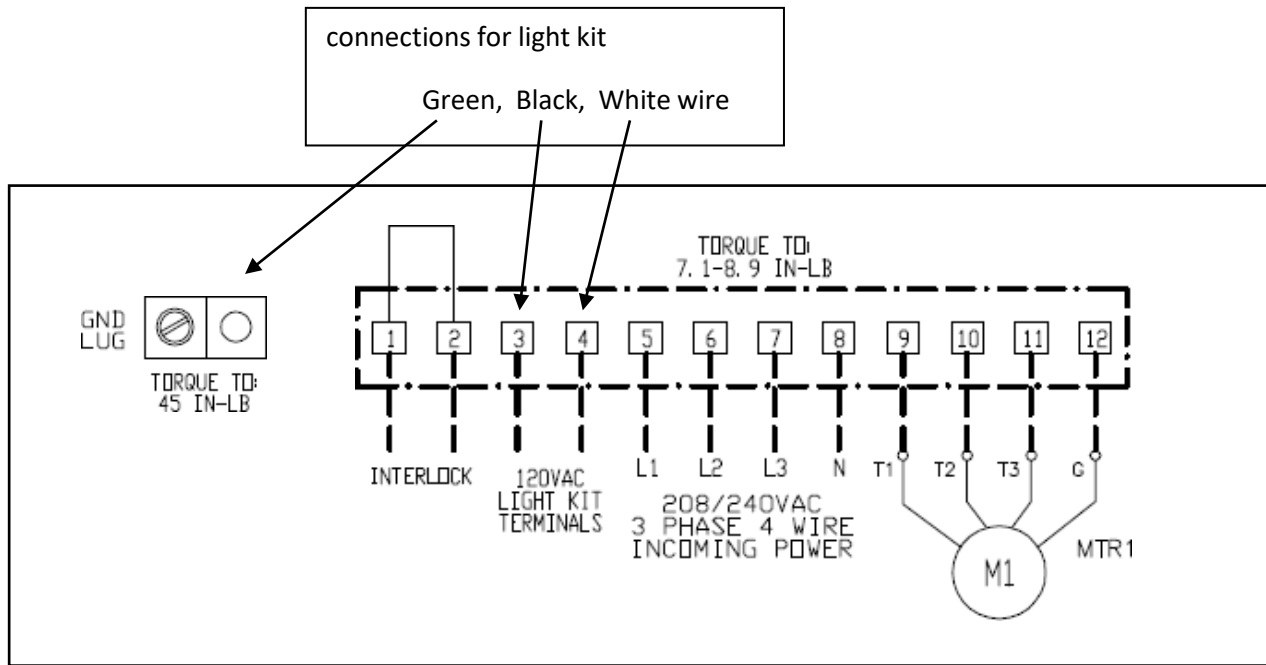

4. Wiring RGBW light kit to RGBW control panel.

- With power disconnected to the RGBW control panel, connect the light kit cord to the RGBW control panel wire terminals
- Terminal #3 to Black wire (line)
- Terminal #4 to white wire (neutral)
- Terminal #5 to Green wire (ground)
- Terminal #6 to Orange wire (DMX+)
- Terminal #7 to Blue wire (DMX common)
- Terminal #8 to Red wire (DMX-)

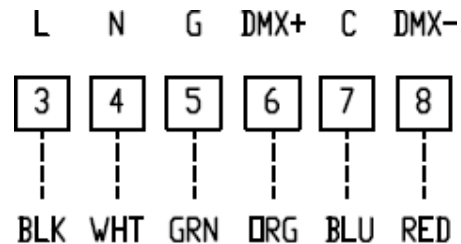

Field connection Terminals in RGBW control panel.

Connect the Light kit cord connections to these terminals.

5. Energizing the RGBW control panel

- With all wiring connections made, light kit installed on the fountain, and fountain in the water, it is time to energize the control panels. Energize the fountain panel and set the fountain and light timers to ON. This will start the fountain and energize the RGBW control panel.
- With the RGBW panel now energized you can follow instructions in Step 6 below to control the lights with the RGBW controller.
- NOTE: The RGBW control panel must be powered by a GFCI protected 120Vac 60hz circuit. Kasco fountain control panels provide this GFCI protected circuit as part of their light kit control circuit. Refer to your fountain owner's manual for setting the timers and installation of fountain control panels.

CW4 CONTROLLER OPERATION

RGBW DMX Controller operation

- The CW4 touch DMX controller allows the user to select from 36 preconfigured scenes. These scenes are listed in the table below and are grouped into 6 scene banks.
- The CW4 controller also allows for custom color selection with the color wheel.
- Other features include brightness control and saturation level (more or less white color added)
- The CW4 also has the ability to connect your cell phone wirelessly via built in WiFi network.
- Use the steps below to operate the CW4 controller and to setup your phone for wireless control if desired.
- For additional controller info and setup, refer to the CW4 operation and technical datasheet provided with this control panel.

CW4 Controller Scenes

36 scenes are programmed into the CW4 controller. The scenes are in 6 scene banks.

1-1	White (RGBW)	4-1	7 color quick fade (RGBYCMO)
1-2	Red	4-2	7 color slow fade (RGBYCMO)
1-3	Green	4-3	12 color quick fade
1-4	Blue	4-4	12 color slow fade
1-5	Cyan	4-5	RGB quick jump
1-6	Magenta	4-6	RGB slow jump
2-1	Yellow	5-1	CMY quick jump
2-2	White (only white)	5-2	CMY slow jump
2-3	Orange	5-3	7 color quick jump (RGBYCMO)
2-4	Teal	5-4	7 color slow jump (RGBYCMO)
2-5	Lime	5-5	Christmas (fades between Red and Green)
2-6	Pink	5-6	Breast Cancer awareness (fades between pink and Magenta)
3-1	RGB quick fade (cycles Red - Green - Blue)	6-1	4th of July jump (jump between Red - White - Blue)
3-2	RGB slow fade (cycles Red - Green - Blue)	6-2	4th of July fade (fade between Red - White- Blue)
3-3	RGBW quick fade (Red - Green - Blue - White)	6-3	Valentine's day (Red and Pink fade)
3-4	RGBW slow fade (Red - Green - Blue - White)	6-4	Flame 1 (orange & yellows dancing around) *
3-5	CMY quick fade (Cyan - Magenta - Yellow)	6-5	Rainbow (a rainbow of colors fading between the fixtures) *
3-6	CMY slow fade (Cyan - Magenta - Yellow)	6-6	Swirl (multiple colors swirling around the fixtures) *

* Must set each fixture to different starting address OF: 1, 5, 9 for full effect

CW4 TOUCH-SCREEN CONTROLLER

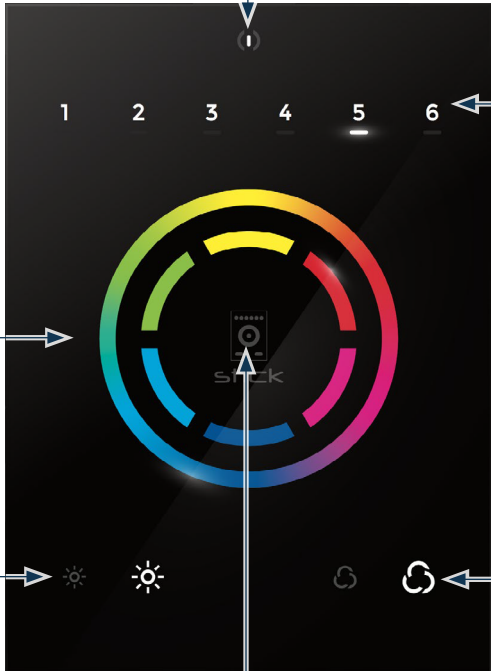

The diagram shows a touch-screen controller interface with the following components and callouts:

- Power button:** Located at the top center, it turns the controller on and off.
- Buttons 1-6:** A row of six numbered buttons (1-6) below the power button. Pressing these will change to the preprogrammed scene. An indicator light below the button will show the active scene.
- Color wheel:** A circular color wheel in the center of the screen. Touching it will change the light output. To return to a programmed scene, double tap one of the scene buttons 1-6. This will put the controller back into a programmed scene. Ensure you double tap a scene button to return from color wheel operation.
- Dimmer buttons:** Two buttons below the color wheel, one with a sun icon and one with a sun icon and a minus sign. They will dim the light output from 1 to 6. The indicator lights under the scene buttons will indicate the dimming level.
- Saturation buttons:** Two buttons below the dimmer buttons, one with a circular arrow icon and one with a circular arrow icon and a minus sign. The normal value is 6. Lowering the saturation will "bleach out" the color. The lowest saturation setting will result in white light output. The indicator lights under the scene buttons will indicate the saturation level.
- Center button:** A small button in the center of the color wheel. Pressing this button will allow you to change the scene bank 1-6. Continue to repress the center button and watch the indicator lights for buttons 1-6 change. The indicator light will blink for the bank to be activated. WHILE FLASHING, press the button for the bank you want; then immediately press the number of the scene you want. If the light stops blinking before selecting a scene, it will revert to the last active bank, and you will need to start over.

ARCOLIS APP CONTROL OF CW4 CONTROLLER

This app replicates the CW4 control panel. It functions the same as the CW4 control panel.

The Arcolis app is available for download in your app store

Perform the following steps to use Arcolis remote control app with the CW4 controller

1. Download and Install the Arcolis app from your app store. The app is available for both Android & iPhone.
2. Ensure the app is closed on your phone
3. Turn on the CW4 controller panel
4. On your phone/tablet go to Wi-Fi settings
 - Find the network: "KascoCW-4" + [your serial number]
 - Connect to it and use Password 00000000 (8 zeros)
5. Once connected, go to the Arcolis app and choose the CW4 controller. When you open the app, this screen will appear:
6. If the controller does not appear on the app. Swipe down to refresh the screen or close the app and re-open.
7. Press on the Stick5A image to go to the control screen.

Press here to choose this controller.
If other controllers were on a LAN network, there would be additional choices.

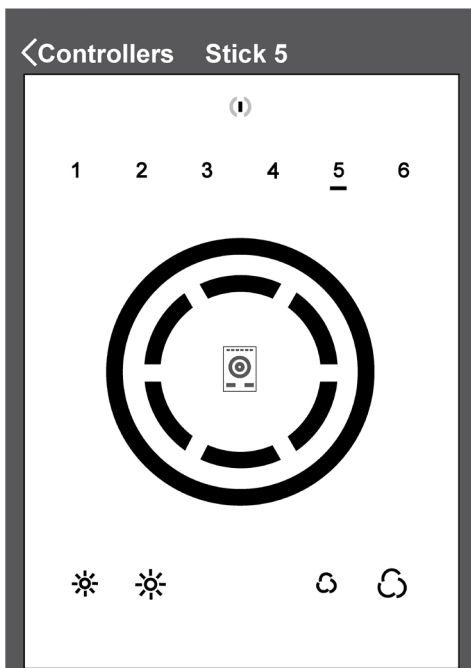
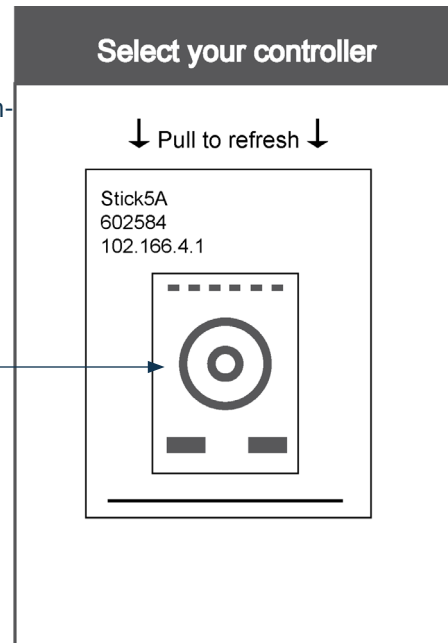

8. The following screen will appear.
 - Use this interface to control the CW4 just as you would from the controller.
 - This screen replicates the operation of the controller's button panel. Go to the Arcolis app and choose the CW4 controller. When you open the app, this screen will appear:

LSTA BUTTON CONTROLLER

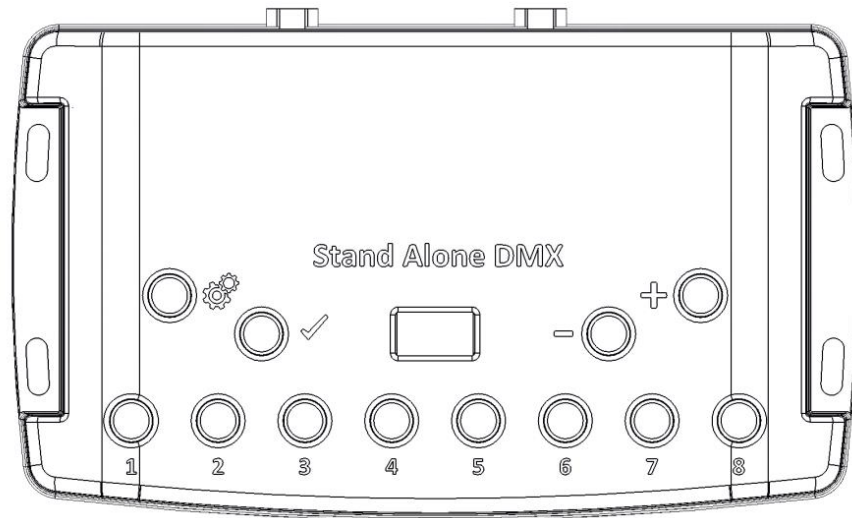

1. The Gear button can be used to change setting mode: Pressing the gear button will display one of the following:
 - SA = standalone mode. This is the mode we use to choose scenes on buttons 1-8 or with the -/+ buttons.
 - PA = change scene page. 10 pages (P0, P1, P2....P9) are available for a total of 80 scenes.
 - This will adjust what scenes buttons 1-8 select.
 - Co = Change color. Use the - /+ buttons adjust the color from 0 to 99 this is similar to a color wheel that will change the color from blue to green to red to white with colors in between
 - SP = Change speed of a color changing scene use the -/+ buttons to change speed from -9 - 0 - 9. -9 is slowest, 0 is normal speed, 9 is fastest.
 - dl = Dimmer change how bright the lights are. If you go above -9 to 0 is off to normal full brightness. 1 to 9 will add white light to the color until it is all white at 9
2. The row of buttons 1 through 8 are for choosing scenes. Default (P0) they choose scenes 1-8. That can be shifted to choose 9-16, 17-24, 25-32, 33-40, etc.... depending on which PA (page) is chosen.
 - To change the PA (page) press the gear button until the screen shows PA, then press the + or - button to increment from PA to P0, P1, P2, P3, P4, etc...
 - P0 = scenes 1-8, P1 = 9-16, P2 = 17-24, P3 = 25-32, P4 = 33-37 (37scenes are programmed)
3. You can also manually increment through the scenes in Standalone mode (SA) by pressing the - or + buttons and then the check mark button. This will activate the scene # you choose.

CONTROLLER OPERATION

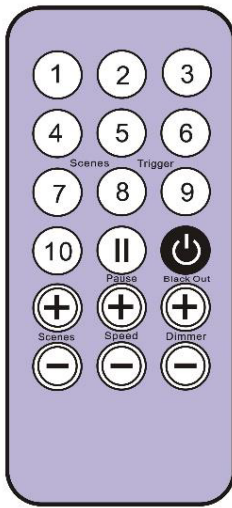

4. Remote control: you can use the remote to change scenes, speed of a color changing scene, dimmer, and turn off a scene.

- Buttons 1 through 10 will choose scenes 1 through 10 directly.
- Scenes can also be incremented up or down with the +/- scene buttons.
- This is how to set a scene number above 10.
- Speed can be adjusted up or down with the +/- speed buttons. Must be a color changing scene
- Dimmer can be adjusted up or down with the +/- dimmer buttons.
- Turn a scene off with the black out button. To turn back on you must select a scene again.
- Pause will stop a color changing scene, press again at it will resume.

The button controller scenes are as numbered below.

1	White (RGBW)	19	7 color quick fade (RGBYCMO)
2	Red	20	7 color slow fade (RGBYCMO)
3	Green	21	12 color quick fade
4	Blue	22	12 color slow fade
5	Cyan	23	RGB quick jump
6	Magenta	24	RGB slow jump
7	Yellow	25	CMY quick jump
8	White (only white)	26	CMY slow jump
9	Orange	27	7 color quick jump (RGBYCMO)
10	Teal	28	7 color slow jump (RGBYCMO)
11	Lime	29	Christmas (fades between Red and Green)
12	Pink	30	Breast Cancer awareness (fades between pink and Magenta)
13	RGB quick fade (cycles Red - Green - Blue)	31	4th of July jump (jump between Red - White - Blue)
14	RGB slow fade (cycles Red - Green - Blue)	32	4th of July fade (fade between Red - White- Blue)
15	RGBW quick fade (Red - Green - Blue - White)	33	Valentine's day (Red and Pink fade)
16	RGBW slow fade (Red - Green - Blue - White)	34	Flame 1 (orange & yellows dancing around) *
17	CMY quick fade (Cyan - Magenta - Yellow)	35	Flame 2 (faster than flame 1)*
18	CMY slow fade (Cyan - Magenta - Yellow)	36	Rainbow*
		37	Rainbow slow roll*

* Must set each fixture to different starting address OF: 1, 5, 9 for full effect

MAINTENANCE RECOMMENDATIONS

Under NO CIRCUMSTANCE should anyone enter the water while a fountain is operating.

The following maintenance procedures can be utilized to ensure many years of quality performance from your Kasco fountain and light kit and reduce the need for more costly repair work.

PROPER INSTALLATION: Proper installation of Kasco equipment will include a power source with ground fault protection. The control panel included with the equipment has built-in ground fault protection for both the fountain and the lighting kit. Ground fault interrupters are a safety feature that can also alert you to electrical leaks in the equipment. If you have repeat, consistent trips of the ground fault device, the equipment should be disconnected and removed from the water. The power cord should be inspected for damage and you should contact your distributor or contact Kasco Marine at 715-262-4488 or sales@kascomarine.com for further instructions. A complete list of control panels can be found in the Accessories section of kascomarine.com.

OBSERVATION: Operating equipment should be observed on a regular basis (daily, if possible) for any reduction or variation in performance. If a change in performance is observed, the equipment should be disconnected from power and inspected.

WINTER STORAGE: In regions where there is significant freezing in the wintertime, the light kit should be removed from the water to protect it from the expansion pressure of ice. Storage over winter is best in a location that is out of the sun and cool, but above 32° F.

CLEANING: Light kits should be removed from the water at least once per year (at the end of the season in cold climates) to clean the exterior of the system. The light fixture surfaces dissipate heat into the water, and any algae, calcium, or other build-up will become an insulator that blocks heat transfer and may lead to overheating and damage. Keeping the lenses clean will also ensure the brightest light possible.

CONTACT US



Kasco Marine
800 Deere Road
Prescott, WI 54021



715.262.4488



kascomarine.com | sales@kascomarine.com

WARRANTY

Warranty Policy

Warranty period: 5 year Limited Warranty: Kasco® Marine, Inc. warrants this Light Kit to be free from defects in material or workmanship under normal use and service. The Kasco Marine, Inc. obligation under this warranty is limited to replacing or repairing free of charge any defective part within the warranty period from the date of shipment. Customer shall pay shipping charges for returning the unit to Kasco.

THIS WARRANTY IS IN LIEU OF ANY OTHER WARRANTIES, EXPRESSED OR IMPLIED, AND ANY OTHER OBLIGATION OR LIABILITY WHATEVER ON THE PART OF KASCO MARINE, INC. AND IN NO EVENT SHALL KASCO MARINE, INC. BE LIABLE FOR ANY SPECIAL OR CONSEQUENTIAL DAMAGES.

Warranty is void if:

- The Light Kit is not maintained properly according to the Maintenance Recommendations supplied in this Manual.
- The lights, control box, or power cord are altered in any way from original shipment. Cuts in the power cord are not covered under warranty.
- The Light Kit is damaged by unauthorized tampering.

Warranty Claim Procedure

The best method for establishing warranty period is by keeping your original receipt and registering the equipment online at kascomarine.com under the Warranty Information section.

Once warranty coverage has been established, the light kit may be sent to Kasco Marine or any Kasco Authorized Repair Center for evaluation and repair.

NON-WARRANTY REPAIRS

Most failed equipment can be repaired at substantially lower costs than replacement with new. If your light kit requires repair and is no longer covered under warranty, please contact Kasco Marine or your local distributor for available options. Please ship according to the instructions above.

- Kasco Marine does estimates on repairs at the request of the customer. The request for estimate should be included in the letter that accompanies the returned unit and must include a daytime phone number and/or e-mail address. We will contact the customer with a total after the unit has been evaluated, but before the work is performed.
- All estimates that are rejected for repair will be destroyed unless otherwise directed by the customer. Rejected equipment can be returned at the customer's expense for shipping and handling charges.

Billing:

All non-warranty repairs will be returned and billed to the customer unless otherwise directed. Kasco Marine accepts Visa and MasterCard credit card payments. Kasco Marine will call for credit card information upon completion of the estimate at the customer's request.

Please see the Product Support section of kascomarine.com for more information about warranty and repairs. Contact Kasco Marine at the number above or sales@kascomarine.com for additional information and your closest Authorized Repair Center.

TROUBLESHOOTING TIPS

The following is provided to help diagnose a probable source of trouble. It is a guideline only and may not show all causes for all problems. For additional troubleshooting help, contact your local distributor or visit kascomarine.com for additional guidance. Note: you may need to refer to your owner's manual that was provided with your fountain for additional control panel settings and adjustments.

"My light kit is installed and wired but will not turn on."

Ensure control panel is connected to the electrical circuit. Verify circuit breakers, timers, and/or interlock switches are turned on and functional. Refer to your owner's manual that was provided with the fountain.

It may not be dark enough for the photo eye on the control panel to activate.

- Kasco C-85 and C-95 control panels have a photo eye on the left side of the enclosure exterior. This photo eye measures ambient light. To activate, the photo eye must not measure any ambient light for at least several minutes. Covering the photo eye with black electrical tape will activate the photo eye for testing.
 - C-85, or C-95 control panel with GFCI outlet and photo eye control: The fountain timer must be turned on (fountain operating) to allow the light circuit to energize. While the photo eye is covered, the GFCI outlet can be reset if tripped.

The timer may not be set properly.

- C-85, or C-95 control panel (and all 3phase fountain control panels) with terminal connections and timer control for light kit: The control panel has a second timer for controlling the lights (no photo eye). Ensure the light timer is set to operate the lights. The timer has a built-in Hand-Off-Auto switch. Ensure the switch is set properly. Ensure the fountain is turned on. The light timer will not energize the light kit unless the fountain circuit is energized.

The GFCI may be tripped.

- C-85, or C-95 control panel with GFCI outlet and photo eye control: To reset the GFCI outlet the fountain timer must be turned on, and the photo eye must be activated. (Black electrical tape can be wrapped around the photo eye to activate it.) Once these are on, the GFCI reset button can be pressed. (Unplug the light kit prior.) Plug the light kit in and see if it operates. If the GFCI trips again then the light kit may be damaged. If the GFCI does not reset (with light kit unplugged) then it may be defective, or the photo eye is not activated to send power to the outlet.
- C-85, or C-95 control panel with terminal connections and timer control for light kit: For panels with a GFCB (ground fault circuit breaker) and timer-controlled lights, simply reset the two-pole breaker. This will turn the fountain and light kit back on if the timers are set to on. If it trips again, disconnect the light kit from the terminals and reset. **WARNING!** You must turn off power to the panel before disconnecting any wiring from the terminals. If the breaker trips with the light kit disconnected, then disconnect the fountain as well and reset. If the breaker continues to trip it may be a defective GFCB. If the breaker resets, then reconnect the fountain then the light kit to see which one trips the GFCB.
- 3phase fountain control panels: 3phase fountain panels have a ground fault sensing module that will trip if either the light kit or fountain has a ground fault. To reset the module, simply press the reset button in the panel. This will turn the fountain and light kit back on if the timers are set to on. If it trips again, disconnect the light kit from the terminals and reset. **WARNING!** You must turn off power to the panel before disconnecting any wiring from the terminals. If the GFI module trips with the light kit disconnected, then disconnect the fountain as well and reset. If the GFI module continues to trip it may be a defective module or an internal wiring issue with the panel. If the module resets, then reconnect the fountain then the light kit to see which one trips the module.

"My lights work, but they are not as bright as they were when first installed."

Dirty lenses may be to blame.

- Turn off power to the control panel and disconnect power cords to the fountain and the light kit. Bring the fountain to the shore and inspect the light kit lenses. Over time, algae growth and hard water deposits on the lenses can block light output. Clean the lenses with a soft brush and the light should be bright again.

REPAIR CONTACT FORM

- Kasco requires that all equipment sent for repair MUST be accompanied by this form and marked to Repairs attention.
- Unit should be cleaned before shipping.
- Kasco is NOT responsible for shipping damage accrued in return shipment.
- It is the responsibility of the customer to ship and pay freight to Kasco.

Kasco Marine
 800 Deere Road
 Prescott, WI 54021
 Attn: Repairs

Note: Contact information should be that of the person or company to contact for repair information.

Company name			
Contact name	First name	Last name	
Address	Street		
	City		
	State		
	ZIP code		
Phone number	Primary	Alternate	
Email address			
Preferred method of contact (circle one)	Phone	Email	
Purchase order number			
Additional product information	Serial Number	Cord Length	
Information for Repair Technician			
Was this unit used in a chemical treatment or wastewater application? (circle one)	Yes	No	
Additional notes			