

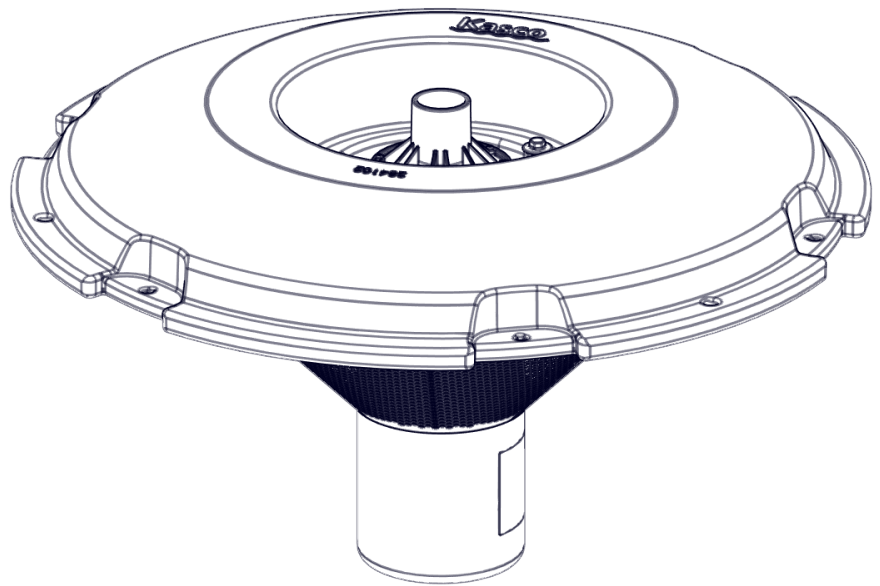

MOVING WATER FORWARD, SINCE 1968



EJ SERIES FOUNTAIN

5.3EHJ

Operation &
Maintenance
Manual



Document number 884157
Document version 2024.1.0

TABLE OF CONTENTS

Unit Specifications.....	1
Safety First.....	2
Parts Included	3
Nozzles Included	4
Premium Nozzles (Not Included)	5
Installation Instructions.....	9
Maintenance Recommendations.....	11
Troubleshooting Tips.....	12
Warranty	13
Other Repairs	14
Repair Contact Form	15

UNIT SPECIFICATIONS

OVERVIEW

Model	HP	Voltage / Phase / Hz	Amperage	Locked Rotor Amps	Suggested Pond Size (m ²)	Min. Depth of Operation
5.3EHJF	5	380 / 3 / 50	7.7	27	10,000	71cm

Wire size for all cord lengths is 2.5mm².

SAFETY FIRST

WARNINGS:



Moving Machinery



Shock Hazard

- NEVER enter the water with the electrical equipment connected and/or in operation.
- All electrical equipment must be Ground fault/leakage current protected. Use of a Ground fault protective device (GFI, RCD, RCBB, or RCBO type device) is required as directed by local and national codes.
- Stay clear of all moving parts.
- NEVER run the unit out of water. This will damage the equipment and pose a danger to the operator.
- Use extreme caution around water, especially cold water.
- NEVER lift or drag the unit by the power cord. Always use the ropes or mount to remove it from the water.
- Do not use waders in deep water or in areas with drop-offs, drastic slopes, or soft bottom material.
- Do not use boats that tip easily for unit installation (such as canoes).
- Follow all boating safety rules and regulations, including wearing a Personal Flotation Device.
- The unit is supplied with an internal grounding conductor. To reduce the risk of electrical shock, be certain that the unit is plugged in/connected to a circuit with ground fault protection.
- Means for disconnection must be incorporated in the fixed wiring, in accordance with local and national wiring rules.
- Consult a qualified electrician for electrical installation.

TOOLS AND SUPPLIES NEEDED

- (3) Anchors or stakes for installing unit
- 208-240V electrical supply near pond on a post with room for mounting the control panel
- (4) #10 x 1" long or longer screws for mounting the control panel
- 9/16" socket with extension and ratchet (optional)
- 7/16" socket and ratchet or combination wrench (optional)
- (3) 12" pieces of 1" galvanized pipe for weighting ropes (optional)

PARTS INCLUDED

ID	Description	Qty	Part #
A	3/8-16 hex head screw	3	820093
B	3/8" lock washer	3	566230
C	3/8" x 1.25" OD fender washer	3	840325
D	Float, single piece	1	See Table below
E	Interchangeable nozzles	5	See "nozzles" section
F	Nozzle O-ring, Large J	1	841217
G	Large JF unit assembly	1	See table below
H	Bottom screen, Large J	1	284101
I	3/8"-16 x 1/2" serrated hex head screw	3	820092
J	7/16" & 9/16" wrench tool	1	284139
K	Rope, 50ft (not pictured)	3	990700
L	Cable tie (not pictured)	8	415038
M	Dielectric grease (not pictured)	1	341300

Unit Assembly Table

Unit Size	Voltage/Phase	G (Part #)	D (Part #)
5 HP	380 / 3	5.3EHJF	284105

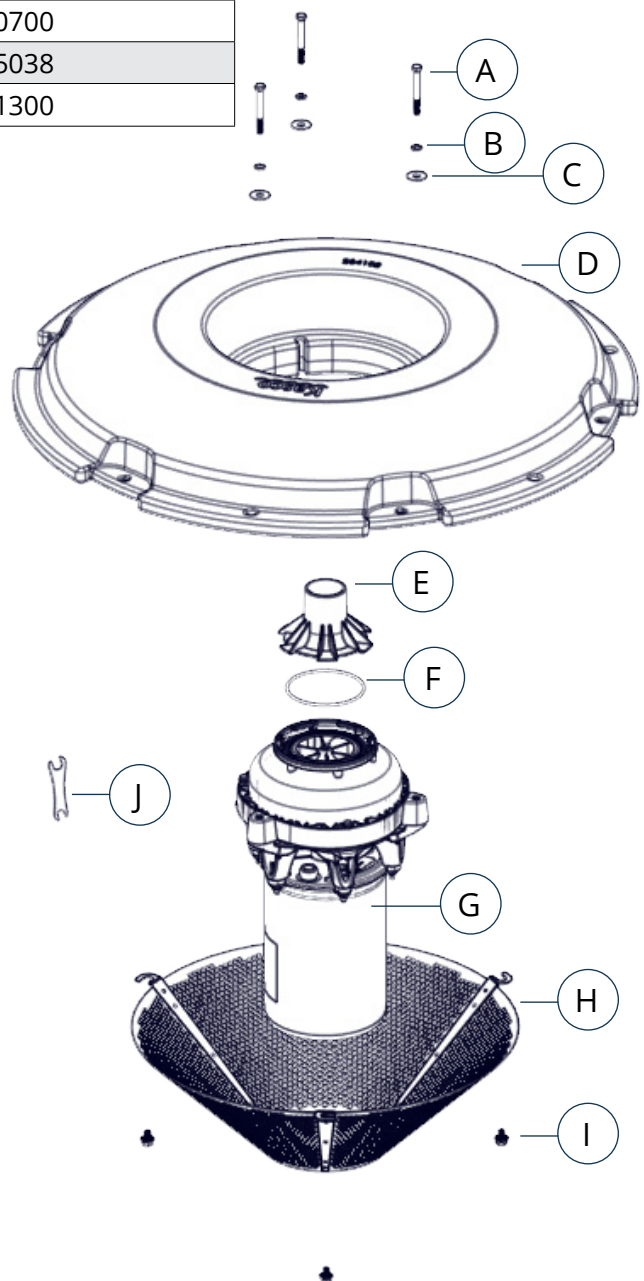

NOZZLES INCLUDED

NOTE  The outlet nozzle (841222) comes installed. Add the parts listed below for Linden and Balsam patterns; remove it before installing Birch, Spruce, or Redwood nozzles.

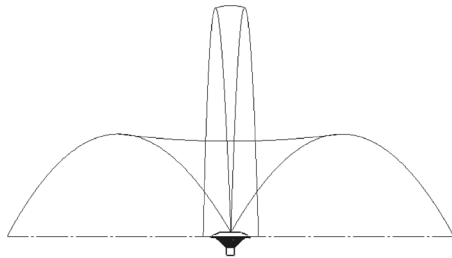

Linden (841261)

HP	Height	Width
5	6.2m	12.2m

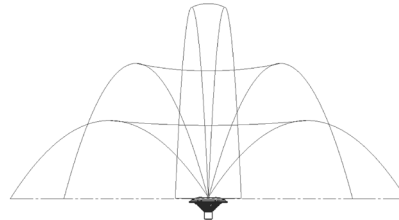

Balsam (841273)

HP	Height	Width
5	4.7m	9.4m

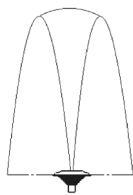
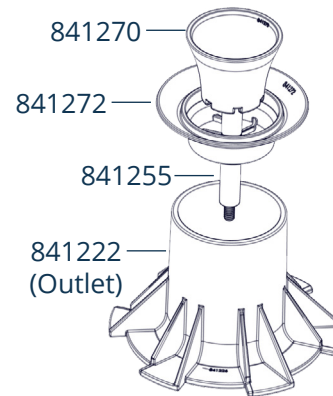
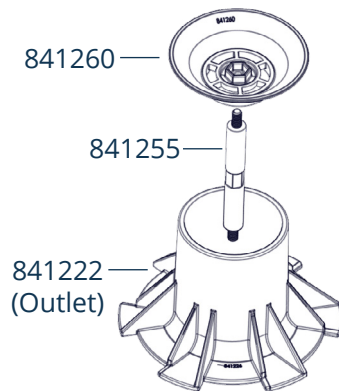

Birch (841222)

HP	Height	Width
5	5.8m	3m

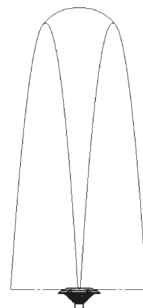

Spruce (841242)

HP	Height	Width
5	7.9m	2.7m



Redwood (841250)

HP	Height	Width
5	8.1m	1.8m

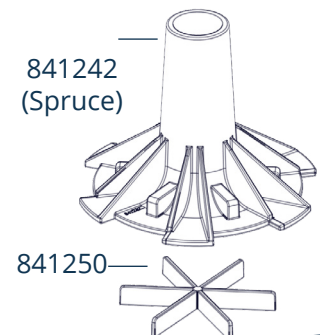
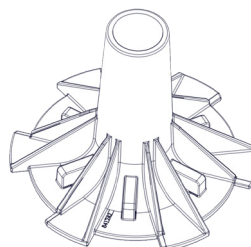
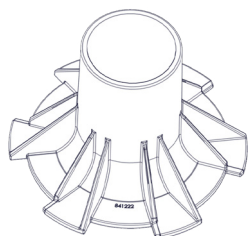

PREMIUM NOZZLES (NOT INCLUDED)

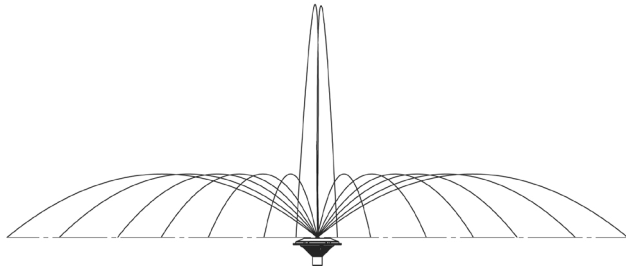

Madrone (841330)

HP	Height	Width
5	7m	18.9m

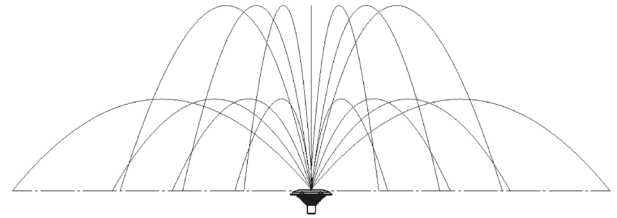

Magnolia (841325)

HP	Height	Width
5	6.2m	22.6m

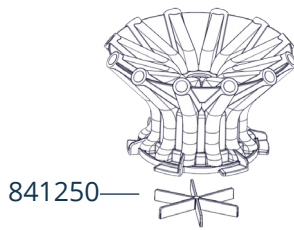

841250

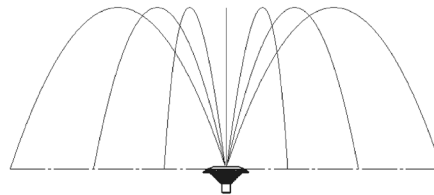

Palm (841320)

HP	Height	Width
5	5.1m	10.4m

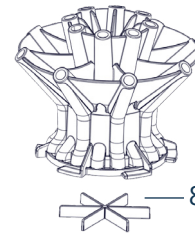

841250

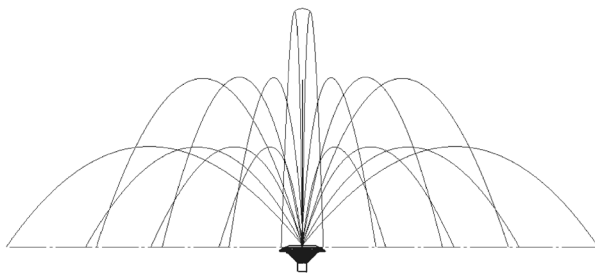

Mahogany (841345)

HP	Height	Width
5	6.9m	18.9m



841250

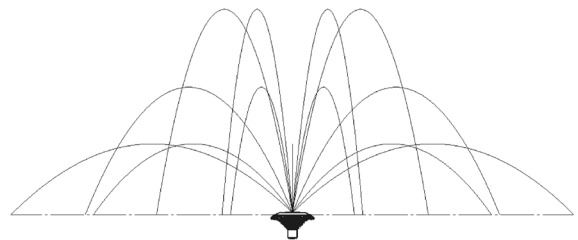

Mighty Oak (841335)

HP	Height	Width
5	6.9m	18.3m

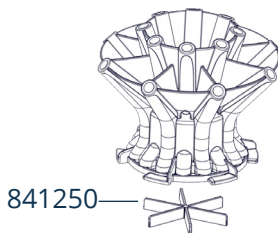

841250

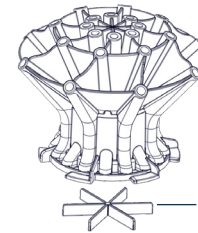

841250

Contact Kasco Marine at sales@kascomarine.com or your local distributor for order information.

ASSEMBLY INSTRUCTIONS

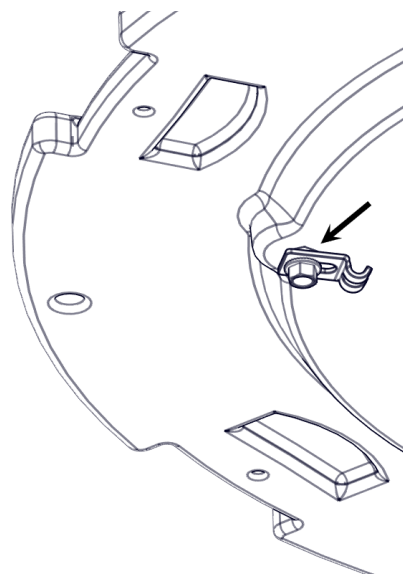
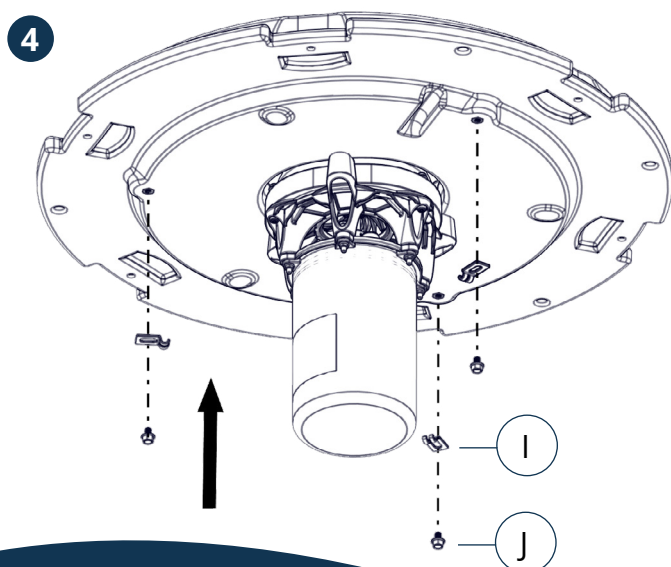
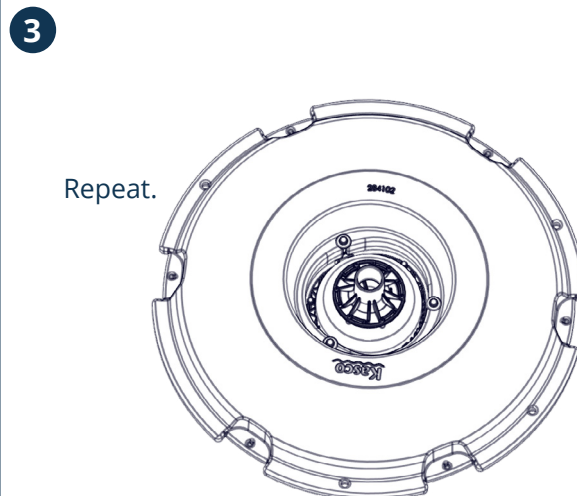
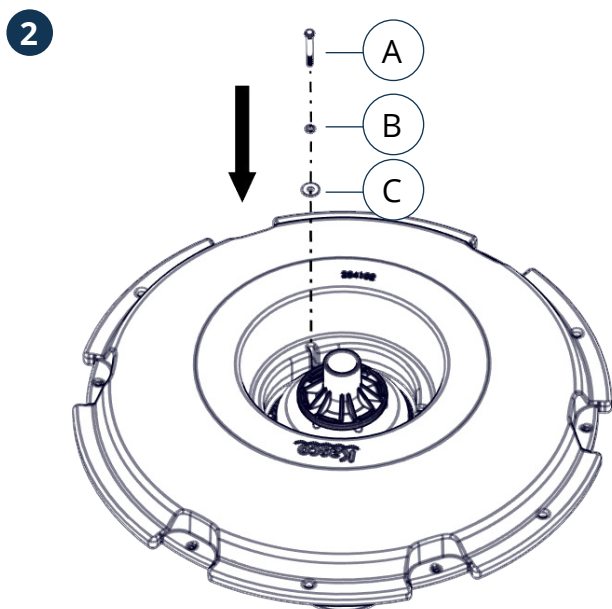
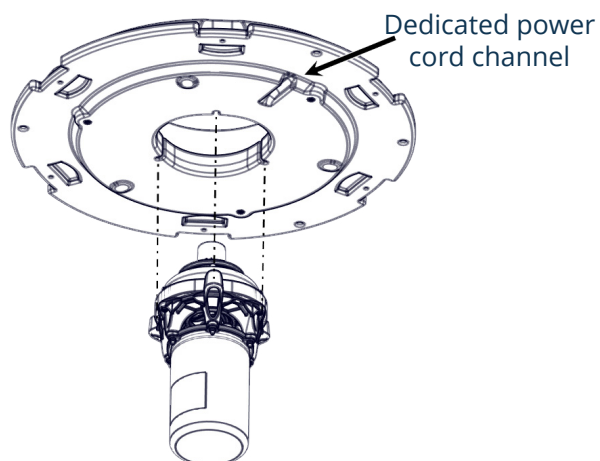
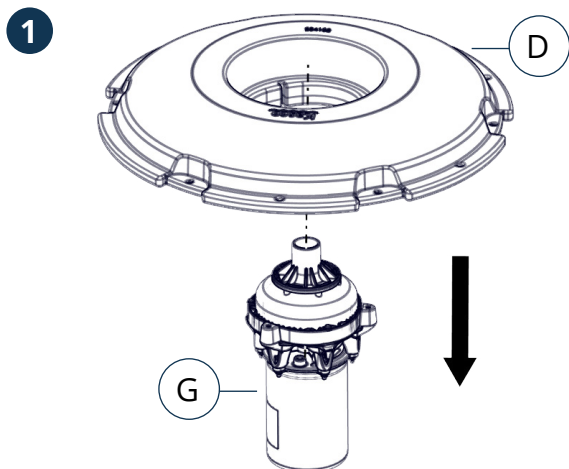

ASSEMBLY INSTRUCTIONS (CONT.)

Use cable ties to secure close mesh screen and then to secure it to the metal bottom screen.

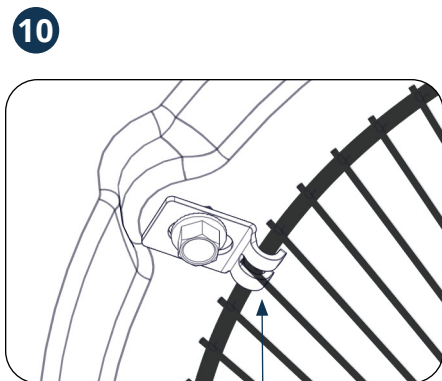
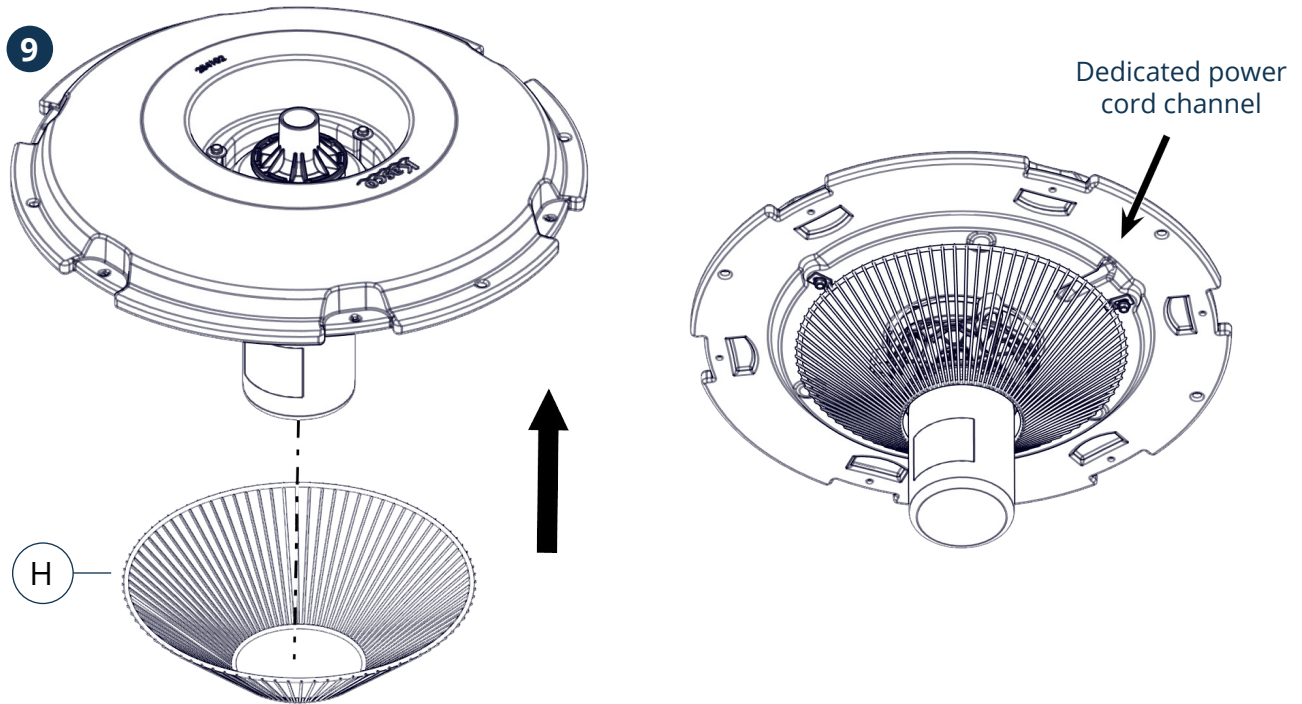
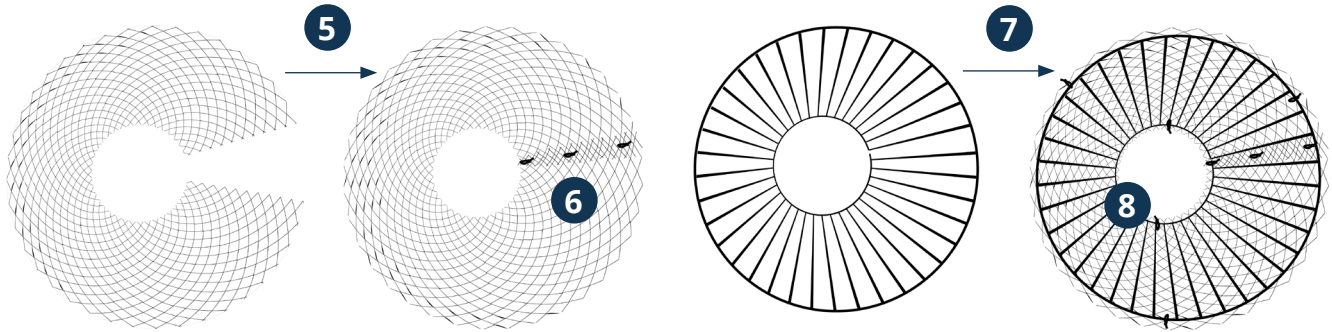

Vertical bar in between clip flanges

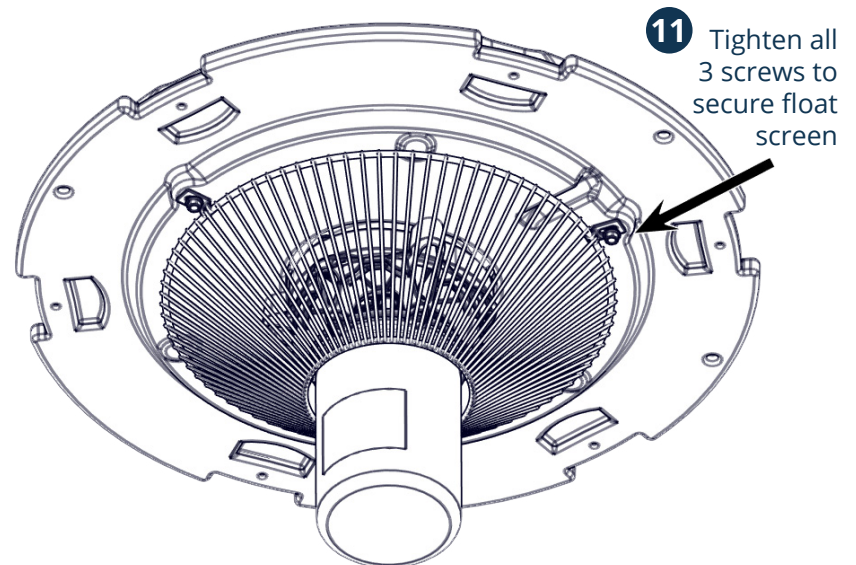

NOZZLE INSTALLATION INSTRUCTIONS

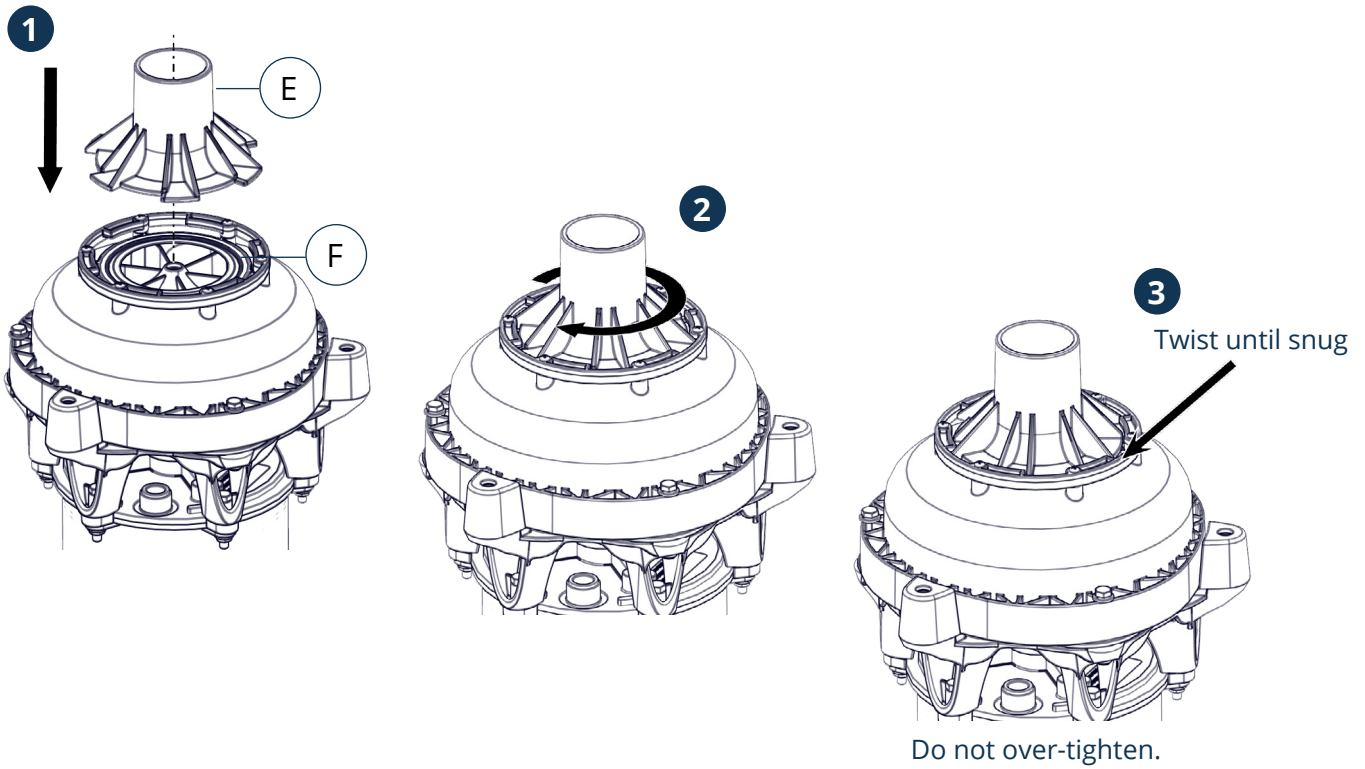

For Linden/Balsam Nozzles:

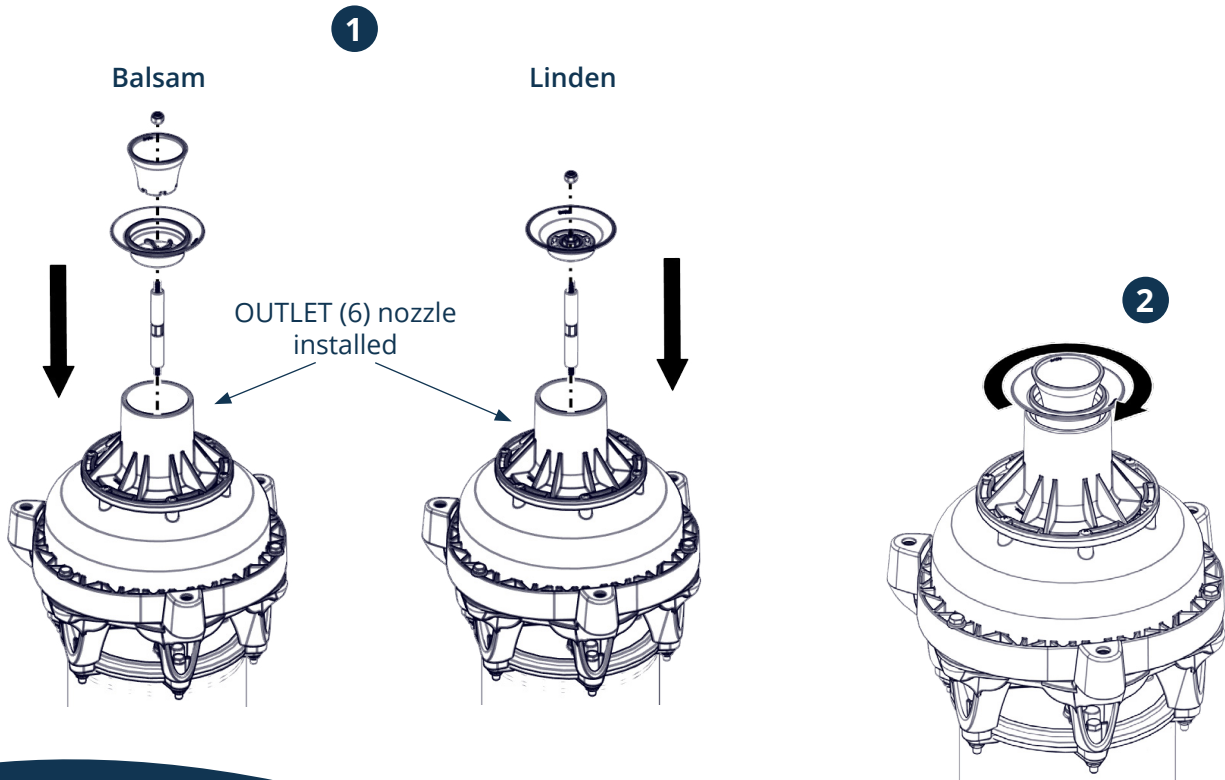

INSTALLATION INSTRUCTIONS

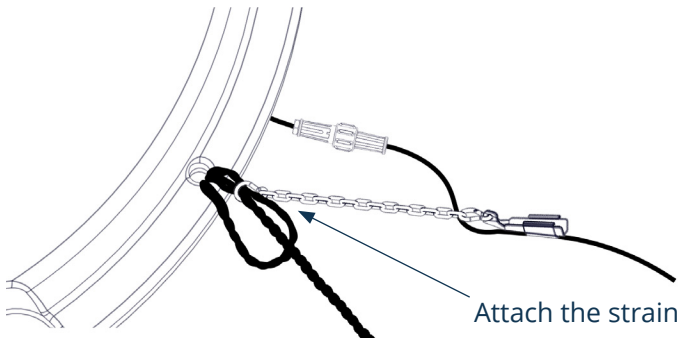

Attach the strain relief to the line closest to the cord.

Correct anchoring

Mooring lines are proper length and taut between unit and anchors (at least 3 feet from the float for every foot of water depth).

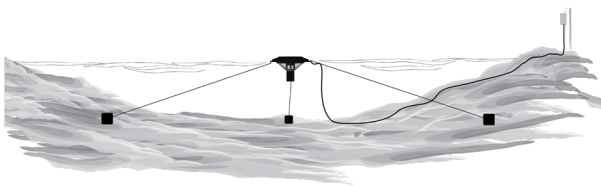

Incorrect anchoring

Mooring lines are too short or loose between unit and anchors.

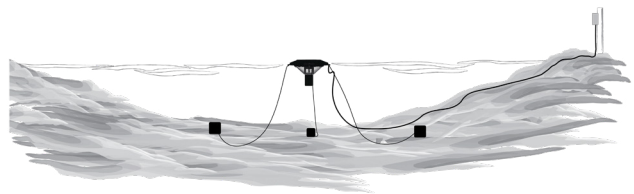

Alternate Installation

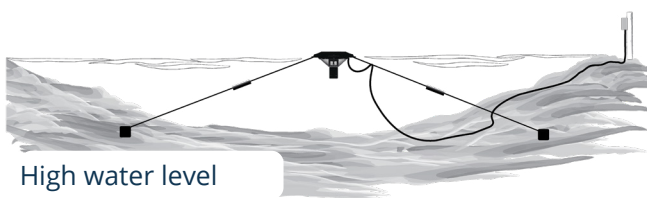
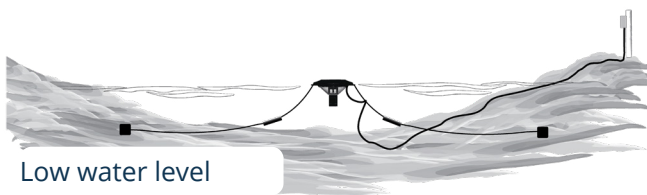
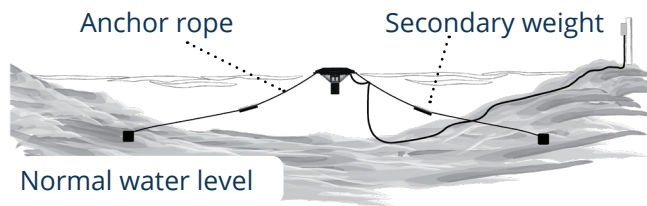

3-PHASE STARTUP PROCEDURE

Required motor starting/overload protection is not provided with this motor equipment. The installer must supply a controller (control panel) with approved motor control and overload protection that matches motor input Full load amperes. (See table below.) Overload protection must be selected or adjusted in accordance with motor controller instructions.

Controller/control panel must also include Ground fault/leakage current protection. Installer must include Ground fault/leakage current protection such as a GFI, RCD, RCBB, RCBO according to local and national codes.

3-phase 380V	5.3EHJF
Full load amps	7.7

Control panels must be installed by a qualified electrician.

If unit is connected to a circuit protected by a fuse, use a time-delay fuse with this pump.

You must verify motor rotation before installing the unit in the water. 3-phase Kasco units will run in a clockwise rotation when looking down at the propeller. Keep clear of the propeller while verifying rotation. Air will be blowing out (up) of the pump chamber when rotating in the correct direction.

Electrician:

1. Verify all screw terminal connections are tightened to specified torque setting prior to energizing the panel.
2. Verify the electrical service (voltage and phase) matches the control panel and fountain nameplate ratings.
3. Verify all switches, circuit breakers, and motor starters are in the OFF position
4. Connect electrical service to the control panel.
5. Connect the fountain power cord to the panel as shown in the electrical schematic.
6. Adjust motor overload protection according to motor full load amperage and motor controller instructions.
7. Pump rotation: The pump rotation is clockwise when looking down at the propeller. Apply power to the control panel. Turn on the motor starter.
8. Momentarily turn on the fountain. Do not run the fountain for more than a few seconds on shore. If the rotation is not correct, disconnect and lock out power from the control panel. Swap any two of the fountain power cord wires in the panel. This will cause the motor to reverse direction. Reapply power to the panel and verify the rotation is clockwise.
9. Once rotation is verified, with the power disconnected and locked out again, continue with installation of the fountain on page 9.

Record the following data while the unit is operating in the water under load:

L1-L2 _____ Volts	L1 _____ Amps
L1-L3 _____ Volts	L2 _____ Amps
L2-L3 _____ Volts	L3 _____ Amps

Current unbalance should not exceed 5% at full load.

MAINTENANCE RECOMMENDATIONS

Proper Installation

Proper installation of Kasco equipment will include a power source with ground fault protection. There should only be one GFCI in a circuit. Ground fault protection devices can also alert you to electrical leaks in the equipment. It is extremely important to test the device upon installation and every month thereafter to ensure proper operation. In the case of consistent trips of the ground fault device, disconnect the equipment and remove it from the water. Inspect the power cord for damage and contact your distributor or Kasco Marine (1.715.262.4488, support@kascomarine.com) for further instructions. Kasco recommends placing an extra serial number sticker on the inside of the control panel cover.

ALWAYS DISCONNECT POWER BEFORE PERFORMING MAINTENANCE.

Observation

Observe equipment in operation on a regular basis (daily, if possible). If you observe a change in performance, disconnect the equipment from the power source and inspect for any material clogging the system or wrapped around the motor shaft. To avoid damage to the equipment, it is important to remove clogs as soon as possible. ALWAYS DISCONNECT POWER TO THE UNIT BEFORE ATTEMPTING TO REMOVE CLOGS.

Cleaning

Buildup of algae, calcium, barnacles, or other matter on the motor housing creates insulation and blocks heat transfer, so to prevent overheating, it is important to clean the unit. In warmer regions or in other areas prone to buildup such as this, inspect and clean the equipment regularly. In all regions, inspect and clean the equipment at least once a year. It is easiest to clean the unit immediately after removing it from the water, when the equipment is still wet. If you use a power washer, avoid hitting the mechanical seal area directly.

Unit Storage

Store the equipment with the cage down if it is going to be out of the water for long periods of time, such as during off-season storage. Seals on units that sit upright on a shelf for extended periods of time are more likely to dry out. Storing upside down or sideways will ensure oil is reaching the seals and help to prevent drying.

Sacrificial Anode

All Kasco units include a sacrificial anode installed on the shaft to protect against corrosion and electrolysis. Replace the anode if it is reduced to half the original size or if it is white in color. Corrosion from electrolysis most commonly occurs in saltwater or brackish water, but it is important to check the anode in all installations at least every two to three months.

Seal And Oil Replacement

This is a sealed motor assembly. Like brake pads on a car, seals wear out over time. Replace the seals and change the oil after three years to increase the motor's longevity and to avoid more expensive repairs.

Other Repairs

Seal replacement and all other repair services should be performed at Kasco or a Kasco-trained authorized repair center. Please contact your Kasco distributor or representative to find your nearest service center.

Please keep the original box for maintenance shipping.

TROUBLESHOOTING TIPS

ALWAYS DISCONNECT EQUIPMENT FROM ELECTRICAL SOURCE BEFORE SERVICING

SERVICE SHOULD ONLY BE PERFORMED BY A QUALIFIED TECHNICIAN OR ELECTRICIAN

Ground fault/earth leakage protection (RCD) tripping

Typically indicates electrical current is leaking to earth (ground).

- Consult a qualified service technician or electrician to address the issue.

Possible causes:

- Control panel damaged or defective ground fault protection device (RCD, GFI)
- Water contamination in the motor unit or Electrical motor damage
- Power cord damage or water leak at quick disconnect

Collect this information for the electrician:

- How long until the RCD trips after resetting?
- Does the trip time vary or repeat the same interval of time?
- Does it trip randomly or same time of day?
- How many times has it tripped?
- Any electrical problems in the area recently, or changes made to site wiring?

Unit appears to run slowly

Typically indicates low voltage to the motor or motor damage.

- Contact a qualified service technician or electrician to measure for proper voltage and motor amps while the motor is operating. Voltage drop should be no more the 5% from power source to motor control panel.

Unit hums and will not start

Typically indicates a motor capacitor problem (single phase motor), a motor controller problem (3 phase), or debris preventing the unit from starting.

- Turn the unit off and disconnect from power source to prevent motor damage.
- Remove the equipment from the water and inspect for debris or damage.
- Remove the debris and clean the equipment.
- If there is no debris in the unit and it will not start. Turn the unit off and contact a qualified service technician to address the issue.

Unit cycles on/off by itself

Typically indicates the motor is overheating. The Motor overload (single phase motor) will automatically reset once cooled down and restart the motor.

Possible causes:

- Low water level, build-up of material on motor can preventing heat dissipation, or debris around the motor shaft or propeller area creating excess motor loading.
- Turn the unit off and disconnect from power source to prevent motor damage.
- Remove the equipment from the water and inspect for debris or damage.
- If there is a build-up on the unit and motor can, remove the debris and clean the equipment.

Unit flow/performance fluctuates

Typically indicates debris is clogging the unit and preventing water flow into the unit.

- Turn the unit off and disconnect from power source.
- Remove the equipment from the water and inspect for debris or damage.
- If there is build-up on the unit and motor can, remove the debris and clean the unit.

WARRANTY

Warranty Period: 2 years

Kasco® Marine, Inc. warrants this equipment to be free from defects in material or workmanship (except for the ropes, power cord, and propeller) under normal use and service. The Kasco Marine, Inc. obligation under this warranty is limited to replacing or repairing free of charge any defective part within the warranty period. The customer shall pay shipping charges for returning the unit to Kasco or an authorized repair center.

THIS WARRANTY IS IN LIEU OF ANY OTHER WARRANTIES, EXPRESSED OR IMPLIED, AND ANY OTHER OBLIGATION OR LIABILITY WHATEVER ON THE PART OF KASCO MARINE, INC. AND IN NO EVENT SHALL KASCO MARINE, INC. BE LIABLE FOR ANY SPECIAL OR CONSEQUENTIAL DAMAGES.

Warranty is void if:

- The equipment is not maintained properly according to the maintenance recommendations supplied in this manual.
- The equipment is returned for repair without the power cord, or if the unit, control box, or power cord are altered in any way from the original shipment. Cuts in the power cord are not covered under warranty.
- The equipment is damaged by unauthorized tampering.
- The sacrificial anode around the propeller shaft shows significant deterioration. (The anode must be inspected periodically and replaced as necessary.)

Warranty Claim Procedure: The best method for establishing warranty period is via the original receipt. Also, register the unit online at: www.kascomarine.com. Once the warranty coverage has been established, the unit may be sent to any Kasco authorized repair center for evaluation and repair. Please call Kasco at 715-262-4488 prior to shipping to receive any updated information or a repair form, or call to locate your nearest authorized repair center. You can also email Kasco at sales@kascomarine.com.

Please include the repair form received from Kasco or your local distributor with the shipment. If no repair form is available, include your name and physical address for return delivery of the repaired unit and a daytime phone number and/or email address for correspondence regarding the warranty claim. Any expedited shipping method for the return of the unit is at the customer's expense. For repairs covered under warranty, Kasco will cover the cost of returning the unit to the customer. The credit will be calculated based on the US Dollar exchange rate on the date of shipment.



Kasco only accepts complete assemblies for warranty repair. We must receive the power cord and all other components with the motor as originally assembled. **THIS DOES NOT INCLUDE CONTROL PANEL, FLOAT, MOUNT, OR ANY OTHER PARTS THAT CAME IN ADDITION TO THE MOTOR ASSEMBLY, UNLESS SPECIFICALLY REQUESTED BY A KASCO REPRESENTATIVE.** Kasco will bill the customer to replace any missing parts necessary for repair.

Please attach a repair form with the shipment. The repair form must include a name, physical address (for return delivery of the repaired unit), daytime phone number, and an e-mail address for correspondence regarding the warranty claim.

Any expedited shipping method for the return of the unit is at the customer's expense.

OTHER REPAIRS

Most failed equipment can be repaired at substantially lower costs than that of replacing it with new equipment. Please ship according to the instructions in the previous section.

Kasco does estimates on repairs at the request of the customer. The request for an estimate should be included in the letter that accompanies the returned unit and must include a daytime phone number and/or email address. Estimate options are as follows:

- We will contact the customer with a total estimated cost for repairs after we have evaluated the unit but before we perform the work.
- We will repair the unit only if repair costs are under a dollar amount stated by the customer. Example: "Please repair if total is under \$150.00 before shipping charges."

All estimates that are rejected for repair will be destroyed unless otherwise directed by the customer. If the customer would like the unit returned, we will restore the unit as closely as possible to the condition in which we found it and ship at the customer's expense (including shipping and handling charges).

Billing: Kasco accepts Visa, MasterCard, and American Express credit card payments. Kasco will call for credit card information upon completion of the estimate at the customer's request. All other warranty and repair inquiries should be directed to Kasco at 1.715.262.4488 or support@kascomarine.com

CONTACT US



Kasco Marine
800 Deere Road
Prescott, WI 54021



1.715.262.4488



kascomarine.com | support@kascomarine.com

REPAIR CONTACT FORM

- Kasco requires that all equipment sent for repair **MUST** be accompanied by this form and marked to Repairs attention.
- Unit should be cleaned before shipping.
- Kasco is **NOT** responsible for shipping damage accrued in return shipment.
- It is the responsibility of the customer to ship and pay freight to Kasco.

Kasco Marine
 800 Deere Road
 Prescott, WI 54021
 Attn: Repairs

Note: Contact information should be that of the person or company to contact for repair information.

Company name			
Contact name	First name	Last name	
Address	Address line 1		
	Address line 2		
	Country		
	Postal Code		
Phone number	Primary	Alternate	
Email address			
Preferred method of contact (circle one)	Phone	Email	
Purchase order number			
Additional product information	Serial Number	Cord Length	
Information for Repair Technician			
Was this unit used in a chemical treatment or wastewater application? (circle one)	Yes	No	
Additional notes			