

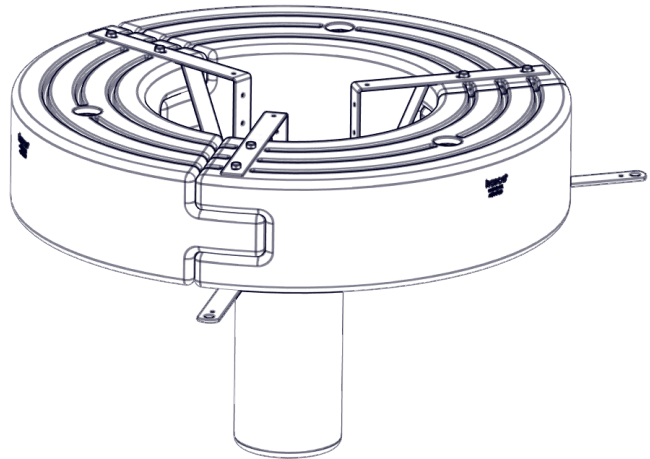

MOVING WATER FORWARD, SINCE 1968

SURFACE AERATOR

8400A, 3.1A, 5.1A,
2.3A, 2.3HA, 3.3A,
3.3HA, 5.3A, 5.3HA

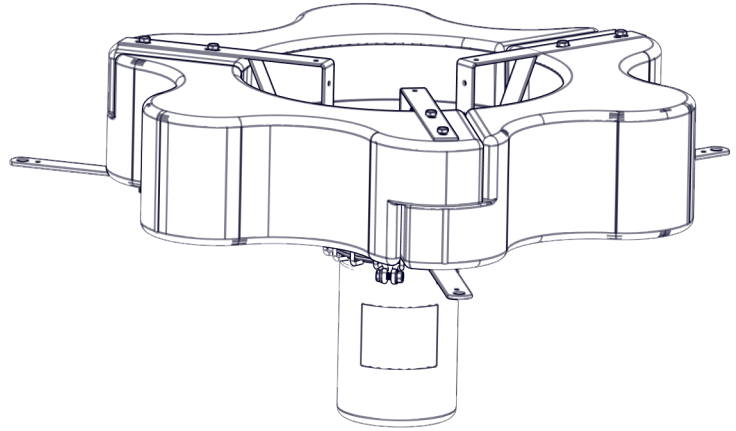

Operation & Maintenance Manual



3020379
ANSI/UL 778: 2016
Ed.6+R:22Feb2017
CSA C22.2 #108: 2014 Ed.5

Document number 884745

Document version 2024.1.0

800 Deere Rd. Prescott, WI 54021 | 715.262.4488 | support@kascomarine.com | kascomarine.com

TABLE OF CONTENTS

Safety First.....	2
Unit Specifications.....	3
General Instructions.....	4
Parts Included (2HP).....	5
Parts Included (3-5HP).....	6
Assembly Instructions (2HP).....	7
Optional Bottom Screen Assembly.....	9
Assembly Instructions (3-5HP).....	10
Installation Instructions.....	12
Three-Phase Startup Procedure.....	13
Maintenance Recommendations.....	14
Troubleshooting Tips.....	15
Replacement Parts (2HP).....	17
Replacement Parts (3-5HP).....	18
Warranty.....	19
Repair Contact Form.....	21

QUESTIONS?



715.262.4488



kascomarine.com | support@kascomarine.com

SAFETY FIRST

IMPORTANT: PLEASE READ THIS MANUAL AND SAVE FOR FUTURE REFERENCE

WARNINGS:



Moving Machinery



Shock Hazard

Please read and follow these extremely important safety and handling instructions for your Kasco equipment. Following these instructions will help ensure your safety and the quality performance of your equipment.

- Under NO circumstances should anyone enter the water with the electrical equipment plugged in and/or in operation. All Kasco equipment is ETL approved to UL and CSA standards for safety in water. However, it is NEVER recommended to enter the water with the equipment in operation.
- Use caution when dealing with any electrical and/or moving equipment.
- NEVER run the unit out of water. It will damage the seals and create a dangerous situation for the operator.
- Use extreme caution around water, especially cold water, such as in spring, fall, and winter, which poses a hazard in itself.
- NEVER lift or drag the water aerator by the power cord. If you need to pull the unit to the side of the pond, use the anchoring ropes or mount apparatus.
- Do not use waders in deep ponds/lakes or ponds/lakes with drop-offs, drastic slopes, or soft bottom material.
- Do not use boats that tip easily, such as canoes, for aerator installation, and follow all boating safety rules and regulations, including wearing a PFD (Personal Flotation Device).
- 3 phase aerators (2.3, 3.3, 5.3) require a startup test after wiring to ensure proper rotation of the propeller. If the propeller is rotating in the opposite direction, the unit will not perform properly and internal damage to the unit may occur. (See 3-phase startup procedure instructions on page 13.)
- Control panels must be installed a minimum of 5ft (1.5m) from the inside wall of the pond, unless separated from the body of water by a fence wall, or other permanent barrier that will make the unit inaccessible to persons in the water.
- Control panels must be installed by a qualified electrician.
- Ground Fault Circuit Interrupters (GFCI) should be tested upon each installation and every month thereafter to ensure proper operation.
- Please keep the original box for maintenance shipping.

UNIT SPECIFICATIONS

Model	HP	Voltage	Operating Amps	Locked Rotor Amps
Single-phase Aerators				
8400A	2	208-240	9.0	40
3.1A	3	208-240	10.7	63
5.1A	5	208-240	18	97
3-phase Aerators				
2.3A	2	208-230	4.5	40
2.3HA	2	460	2.3	20
3.3A	3	208-230	8.2	70
3.3HA	3	460	4.1	35
5.3A	5	208-230	13	100
5.3HA	5	460	6.5	50

SUGGESTED TOOLS & SUPPLIES

- Three anchors or stakes for installing unit
- 9/16" wrench and socket
- 7/16" wrench

Optional:

- Three 12" pieces of 1" galvanized pipe

GENERAL INSTRUCTIONS

Inspect the Shipment

Immediately inspect your Kasco Aerator shipment for any visible damages. Any damage should be reported immediately to your carrier and Kasco.

Assembly & Installation

Please see the proper assembly and installation Instructions enclosed in this manual. Each is specific for your model and size of Aerator. Note: It is extremely important to test the GFI breaker in the control panel upon each installation/re-installation of the unit to ensure proper functioning.

Use and Operation

Kasco Aerators are designed and engineered for continuous duty, such as on fish farms or other aquaculture applications, or on-demand use, as needed in a recreational water feature. During flotation operation, the water is pulled from 360° around the unit and from below the unit. The water is pulled upward and thrust through the flotation collar into the air. Your Kasco Marine Aerator is ready for immediate use (after installation). Make sure to keep the motor housing clean from hard water deposits and/or algae. (See Maintenance Recommendations.) Kasco Aerators are lightweight, energy efficient, and easy to install and operate.

PARTS INCLUDED (2HP)

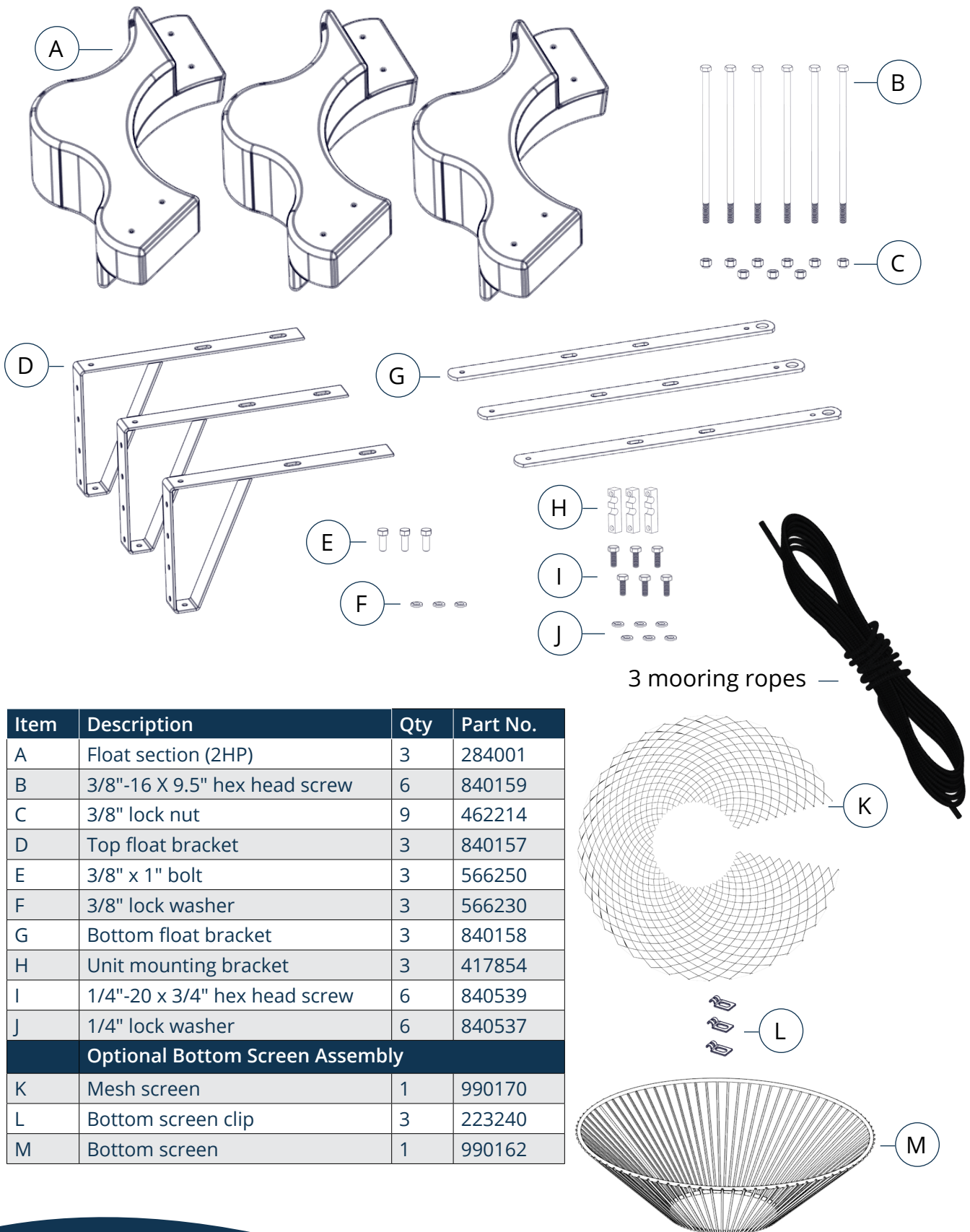

Item	Description	Qty	Part No.
A	Float section (2HP)	3	284001
B	3/8"-16 X 9.5" hex head screw	6	840159
C	3/8" lock nut	9	462214
D	Top float bracket	3	840157
E	3/8" x 1" bolt	3	566250
F	3/8" lock washer	3	566230
G	Bottom float bracket	3	840158
H	Unit mounting bracket	3	417854
I	1/4"-20 x 3/4" hex head screw	6	840539
J	1/4" lock washer	6	840537
Optional Bottom Screen Assembly			
K	Mesh screen	1	990170
L	Bottom screen clip	3	223240
M	Bottom screen	1	990162

PARTS INCLUDED (3-5HP)

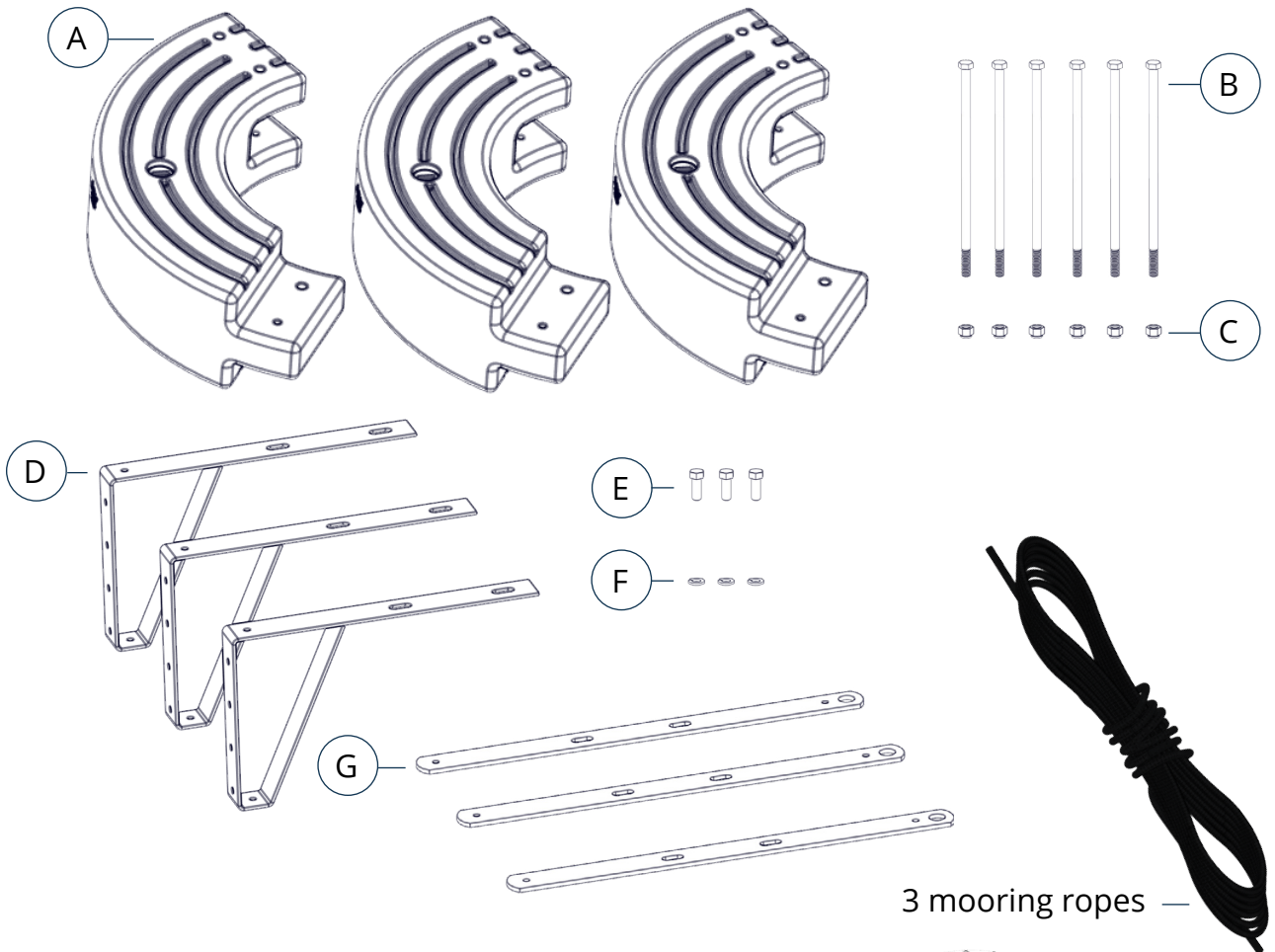

Item	Description	Qty	Part No.
A	Float section (3HP, 5HP)	3	251001
B	3/8"-16 X 9.5" hex head screw	6	840159
C	3/8" lock nut	6	462214
D	Top float bracket	3	840157
E	3/8" x 1" bolt	3	566250
F	3/8" lock washer	3	566230
G	Bottom float bracket	3	840158
Optional Bottom Screen Assembly			
K	Mesh screen	1	990170
L	Bottom screen clip	3	223240
M	Bottom screen	1	990162

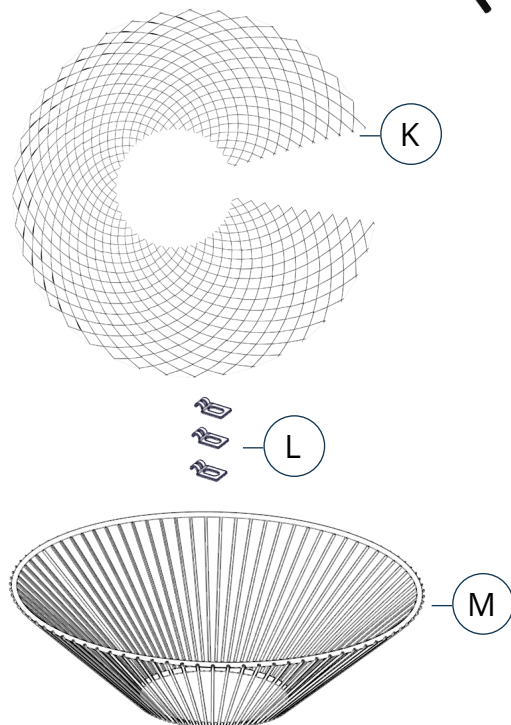

ASSEMBLY INSTRUCTIONS (2HP)

1. Arrange the three float sections (A) upright (plug on bottom) so the overlap of one section aligns with the next section and loosely push the three sections together to form a continuous ring.

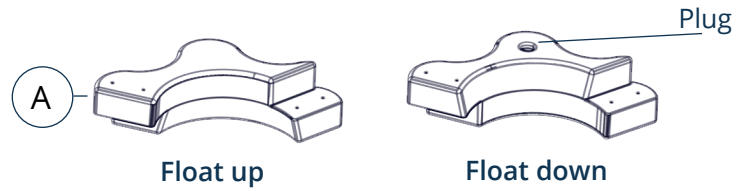

2. Position one top float bracket (D) so that the bolt holes in the bracket align with the bolt holes in the two adjoining float sections.
3. Insert two 9.5" hex head screws (B) through the assembly. This may require some minor repositioning of the float sections as you push the bolt all the way through. Do not force the bolt through. Repeat for the remaining two joints.

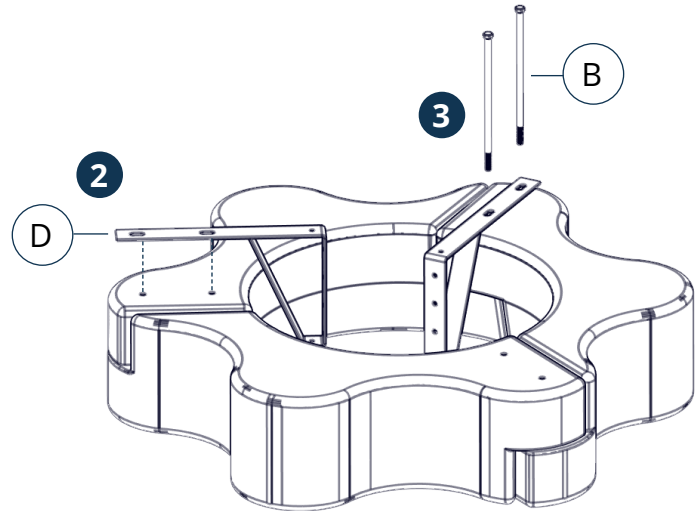

4. Turn the assembly upside down and place the bottom float brackets (G) over the bolts, the ends of which should now be extending through the assembly.
5. Loosely install the six 3/8" lock nuts (C) on the ends of the bolts (do not tighten yet).
6. Connect the top and bottom float brackets using three 3/8" x 1" bolts (E) with three 3/8" lock washers (F) and 3/8" nuts (C). Tighten using the 9/16" wrench.

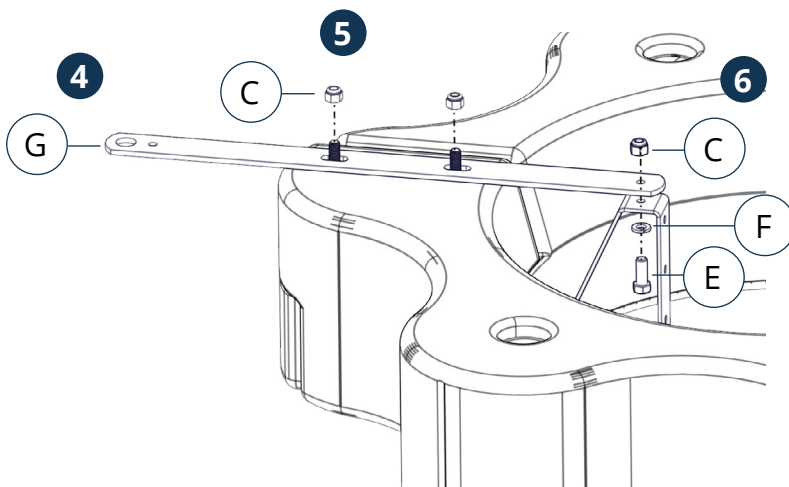

7. Loosely attach the unit mounting brackets (H) to the float brackets with three 1/4"-20 x 3/4" screws (I) and 1/4" lock washers (J) in the top mounting hole as shown. Do not tighten, since you will need to pull the unit mounting bracket away from the top float bracket to accommodate the cage ring once the float and unit are in place.

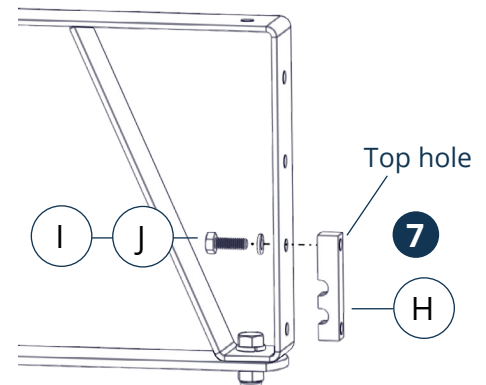

ASSEMBLY INSTRUCTIONS (2HP, CONT.)

- Lift the float assembly and place it over the aerator. Adjust one unit mounting bracket (H) at a time. Nest the cage ring in the middle notch of the unit mounting bracket.

NOTE  Attaching the unit mounting brackets is easiest with another person to assist in holding and repositioning the float as needed.

- Once all three unit mounting brackets are seated correctly on the cage ring, add the remaining 1/4" x 3/4" screws (I) and 1/4" lock washers (J) to lower mounting hole. Tighten all bolts on the unit mounting bracket with 7/16" wrench.

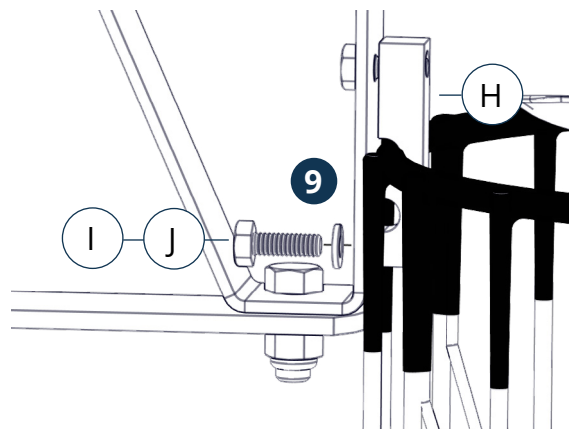
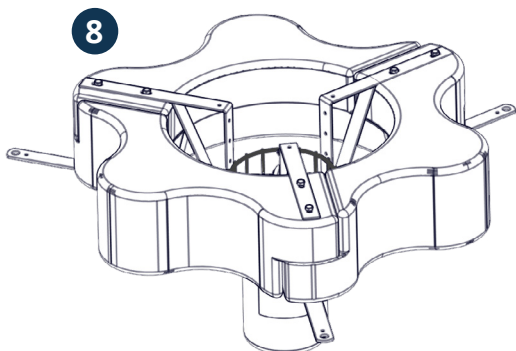

Cord Strain Relief

On power cords 100 feet or longer with the watertight Quick Disconnect, the power cord is shipped separately. It should now be attached to the stub cord by lining up the male and female halves of the disconnect and hand-tightening the blue collar. On these cords, the additional strain relief should be attached to one of the lower float brackets as pictured. If you receive a 3-chain strain relief (6- or 8-gauge cord), attach one chain to each of the three lower float brackets. If there is no strain relief chain, use the nylon cable tie provided to secure the cord to a rope in order to prevent damage by the propeller. Before placing the unit in the water, double-check the Quick Disconnect to make sure the threaded collar has not come loose. If installing a new Quick Disconnect, please refer to Quick Disconnect instructions.

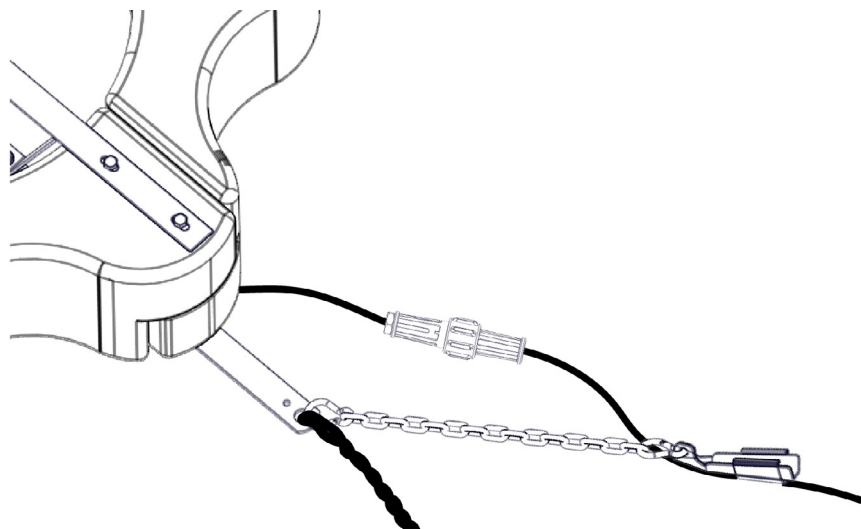

OPTIONAL BOTTOM SCREEN ASSEMBLY

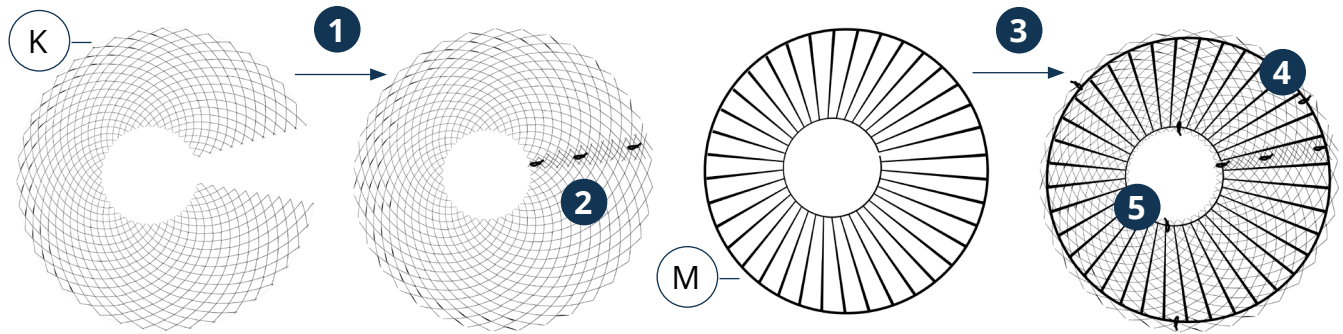

Optional Mesh Screen Attachment

If you are not using a mesh screen, proceed to step 6.

1. Wrap the flat mesh (K) into a cone shape by overlapping both vertical edges by approximately 1 inch and aligning the top and bottom edges of mesh.
2. Use three cable ties evenly spaced along the vertical seam to secure the mesh at the top, middle, and bottom.
3. Center the stainless steel bottom screen (M) inside the mesh cone with approximately 2 inches of mesh above the steel screen's large ring.
4. Use three cable ties evenly spaced around the large ring to attach the mesh to the steel screen.
5. Use two cable ties placed opposite each other on the small ring to further secure the mesh to the screen.
6. Place the aerator assembly inside the screen and raise the screen.
7. Remove the center three lock nuts (C) from the bolts and place the bottom screen clips (L) over the bolts as shown.
8. Position the clip flanges on either side of a vertical bar and replace the inside lock nuts and tighten all nuts using the 9/16" wrench and socket.

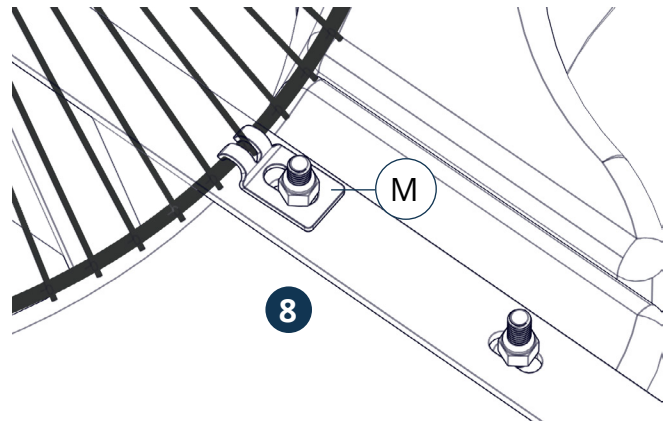
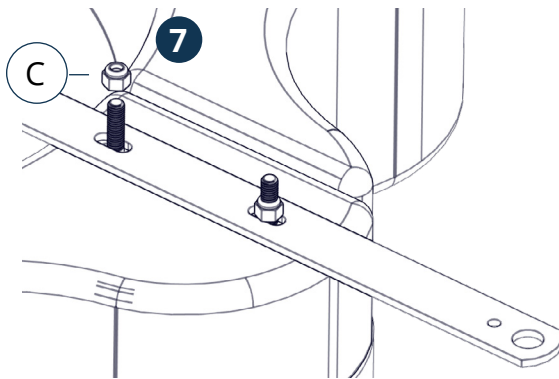
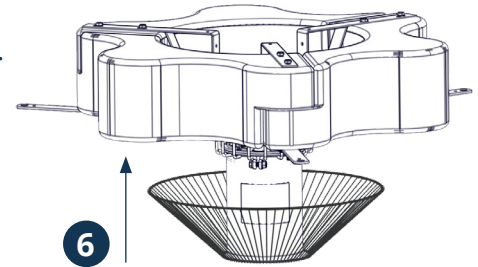

NOTE  Slide the power cord between the float and screen where two float sections come together before replacing the 3/8" lock nuts.

ASSEMBLY INSTRUCTIONS (3-5HP)

1. Arrange the three float sections (A) upright so the overlap of one section aligns with the next section and loosely push the three sections together to form a continuous ring.

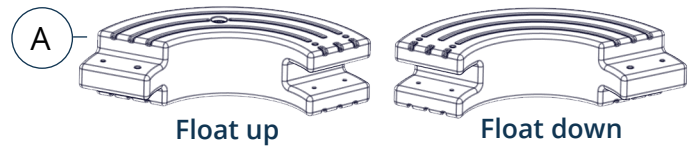

2. Position one top float bracket (D) so that the bolt holes in the bracket align with the bolt holes in the two adjoining float sections.
3. Insert two 9.5" hex head screws (B) through the assembly. This may require some minor repositioning of the float sections as you push the bolt all the way through. Do not force the bolt through. Repeat for the remaining two joints.

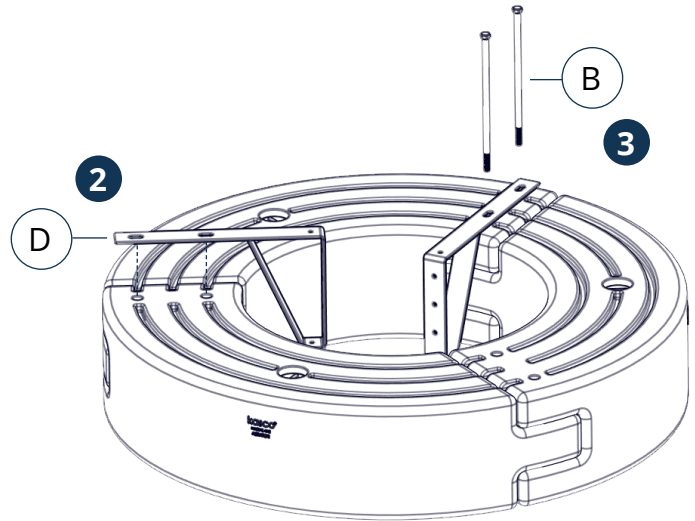

4. Turn the assembly upside down and place the bottom float brackets (G) over the bolts, the ends of which should now be extending through the assembly.
5. Loosely install the six 3/8" lock nuts (C) on the ends of the bolts (do not tighten yet)

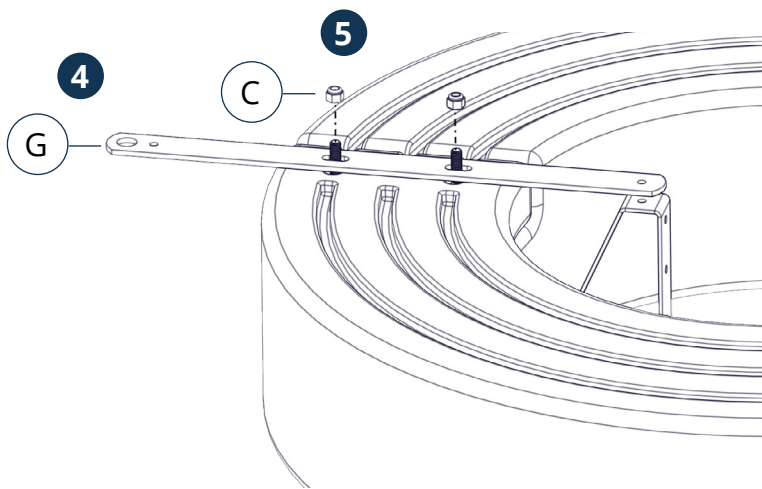

6. Lift the float assembly and place it over the aerator. Use the 3/8" x 1" bolts (E) and 3/8" lock washers (F) to secure the top and bottom float brackets to the aerator mounting ring. Tighten with a 9/16" wrench.

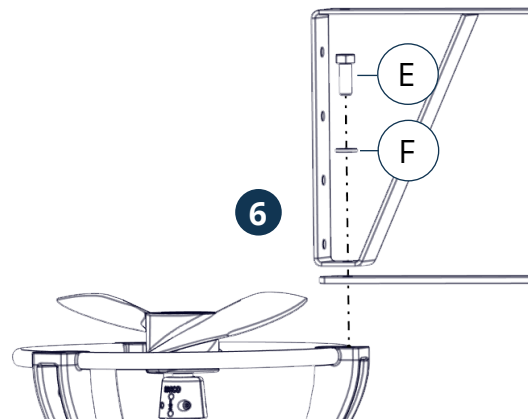

ASSEMBLY INSTRUCTIONS (3-5HP, CONT.)

Optional Bottom Screen Assembly

If you purchased the optional bottom screen, see assembly instructions [on page 9](#). Note that instructions feature drawings of the 2HP model, but the steps are the same for 2HP and 3HP-5HP models.

Cord Strain Relief

On power cords 100 feet or longer with the watertight Quick Disconnect, the power cord is shipped separately. It should now be attached to the stub cord by lining up the male and female halves of the disconnect and hand-tightening the blue collar. On these cords, the additional strain relief should be attached to one of the lower float brackets as pictured. If you receive a 3-chain strain relief (6- or 8-gauge cord), attach one chain to each of the three lower float brackets. If there is no strain relief chain, use the nylon cable tie provided to secure the cord to a rope in order to prevent damage by the propeller. Before placing the unit in the water, double-check the Quick Disconnect to make sure the threaded collar has not come loose. If installing a new Quick Disconnect, please refer to Quick Disconnect instructions.

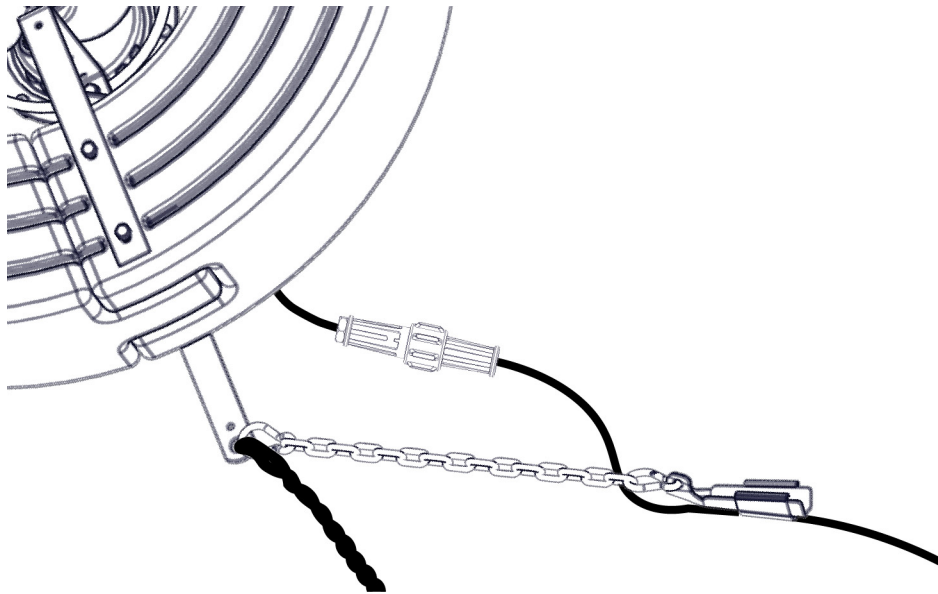

INSTALLATION INSTRUCTIONS

Use ropes to position the aerator in the desired location in the pond or lake. Anchor the ropes or secure them to the shoreline so that they are free of slack, but not tight. To prevent twisting of the unit due to motor torque, place the anchor at least 3 feet from the float for each foot of depth. (Example: a 6-foot-deep pond would require an anchor 18 feet horizontally from the float.)

Correct anchoring

Mooring lines are proper length and taut between unit and anchors.

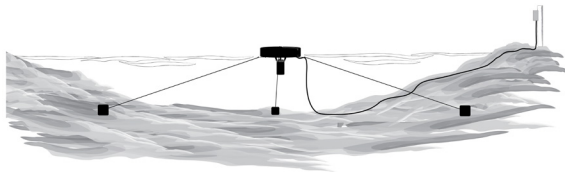

Incorrect anchoring

Mooring lines are too short or loose between unit and anchors.



Alternate Installation

In ponds where the water level fluctuates significantly, a small weight may need to be suspended at the midpoint of the rope to take up any slack caused by a drop in water level (1 foot of 1-inch galvanized pipe works well). The weight should be light enough so that the aerator can rise as the water level rises. This weight can also help hide the anchoring ropes by sinking them further below the surface.

NOTE If your cord does not have a strain relief clamp and chain attached, you can use a spare cable tie to secure the cord to a mooring line attachment point on a circular float or to the tie-down ring on the horizontal float.

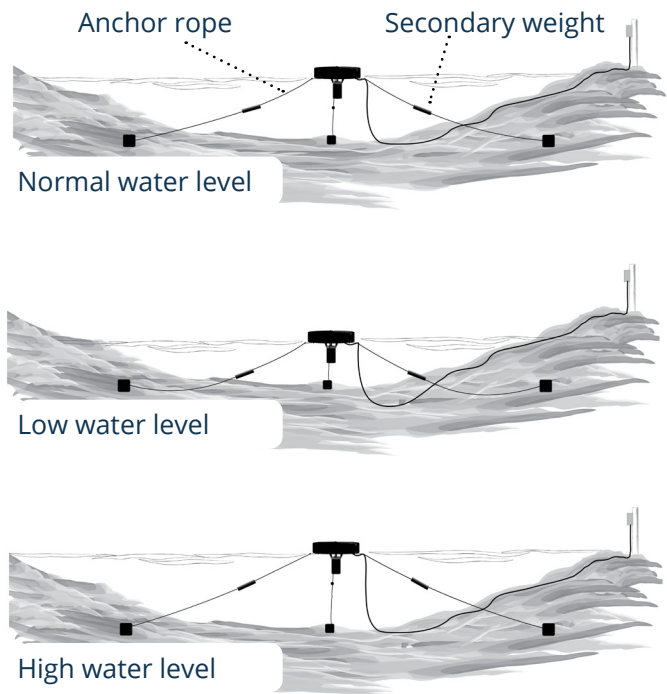

THREE-PHASE STARTUP PROCEDURE

If a Kasco control panel is not provided, please refer to the following warnings:

When inherent overheating protection is not provided, use with approved motor control that matches motor input in full load amperes with overload element(s) selected or adjusted in accordance with control instructions. *Utiliser un démarreur approuvé convenant au courant à pleine charge du moteur et dont les éléments thermiques sont réglés ou choisis conformément aux instructions qui l'accompagnent.*

When inherent overheating protection is provided, use with approved motor control that matches motor input in full load amperes. See table below. *Utiliser un démarreur approuvé convenant au courant à pleine charge du moteur.*

NOTE  The motor input in full load amperes is the marked value or the service factor amperes, shown on the nameplate.

3-phase 208-230V	2.3AF	3.3AF	5.3AF	3-phase 460V	2.3HAF	3.3HAF	5.3HAF
Full load amps	4.5	8.2	13	Full load amps	2.3	4.1	6.5

Control panels must be installed by a qualified electrician.

If unit is connected to a circuit protected by a fuse, use a time-delay fuse with this pump.

You must verify motor rotation before installing the unit in the water. 3-phase Kasco units will run in a clockwise rotation when looking down at the propeller. Keep clear of the propeller while verifying rotation. Air will be blowing out of (up, away from) the unit when rotating in the correct direction. If a Kasco 3-phase panel is supplied, follow the instructions included with the panel in addition to the steps below.

Electrician:

1. Verify all screw terminal connections are tightened to specified torque setting prior to energizing the panel.
2. Verify the electrical service (voltage and phase) matches the control panel and aerator nameplate ratings. Refer to the control panel instructions and schematics for installation details.
3. Verify all switches, circuit breakers, and motor starters are in the OFF position
4. Connect electrical service to the control panel as shown in the electrical schematic that came with the panel.
5. Connect the aerator power cord to the panel as shown in the electrical schematic.
6. Set the motor starter overload to the FLA rating on the aerator nameplate.
7. Pump rotation: The pump rotation is clockwise when looking down at the propeller. Apply power to the control panel. Turn on the 15-amp control circuit breaker and motor starter.
8. Momentarily turn the Hand-Off-Auto switch to Hand. This will run the aerator. Do not run the aerator for more than a few seconds on shore. If the rotation is not correct, disconnect and lock out power from the control panel. Swap any two of the aerator power cord wires in the panel. This will cause the motor to reverse direction. Reapply power to the panel and verify the rotation is clockwise.
9. Once rotation is verified, with the power disconnected and locked out again, continue with installation of the aerator.

Record the following data while the unit is operating in the water under load:

L1-L2 _____ Volts	L1 _____ Amps
L1-L3 _____ Volts	L2 _____ Amps
L2-L3 _____ Volts	L3 _____ Amps

Current unbalance should not exceed 5% at full load.

MAINTENANCE RECOMMENDATIONS

UNDER NO CIRCUMSTANCES should anyone enter the water while equipment is operating.

The following maintenance procedures can ensure many years of quality performance from your Kasco aerator and reduce the need for more costly repair work.

Proper Installation

Proper installation of Kasco equipment will include a power source with ground fault protection. The control panel included with the equipment has built-in ground fault protection. There should only be one GFCI in a circuit. Ground fault interrupters can also alert you to electrical leaks in the equipment. It is extremely important to test the GFCI upon installation and every month thereafter to ensure proper operation. In the case of consistent trips of the ground fault device, disconnect the equipment and remove it from the water. Inspect the power cord for damage and contact your distributor or Kasco Marine (715.262.4488, support@kascomarine.com) for further instructions. A complete list of control panels can be found in the Accessories section of kascomarine.com. Kasco recommends placing an extra serial number sticker on the inside of the control panel cover.

Observation

Operating equipment should be observed on a regular basis (daily, if possible) for any reduction or variation in performance. If you observe a change in performance, disconnect the equipment from its power source and inspect for any material that may have clogged the system or wrapped around the shaft of the motor, especially plastic bags and fishing line. Even though Kasco aerators are among the most clog-resistant on the market, it is impossible to protect against all items that can clog equipment and still maintain a flow of water. These materials can be very damaging to the equipment under continuous operation and must be removed as soon as possible.

ALWAYS UNPLUG THE UNIT BEFORE ATTEMPTING TO REMOVE CLOGS.

Winter Storage

In regions where there is significant freezing in the wintertime, remove the aerator from the water to protect it from the expansion pressure caused by ice. In many areas, aerators will keep some amount of ice open through the winter. However, when the water is thrust into the air, it is exposed to the colder air temperatures longer and can actually make ice thicker on the pond/lake. Storage over winter is best in a location that is out of the sun and cool, but above 32 degrees Fahrenheit. During the offseason, store units upside down (with the float down) if they are going to be sitting for long periods of time. Units that sit upright on a shelf for many months, or even years have a greater likelihood of seals drying out. Storing units upside down will help to ensure oil is lubricating the seals without damaging the propeller guard.

Cleaning

Aerators should be removed from the water at least once per year (at the end of the season in cold climates) to clean the exterior of the system, especially the stainless steel motor housing (can). The motor housing is the surface that dissipates heat into the water, and any algae, calcium, or other build-up will become an insulator that blocks heat transfer. In warmer regions, Kasco recommends removing the motor and cleaning it at least two to three times per year, depending on conditions. In most cases, a power washer will be sufficient if the unit and algae are still wet. Avoid power-washing the mechanical seal area directly.

MAINTENANCE RECOMMENDATIONS (CONT.)

Seal And Oil Replacement

This is a sealed motor assembly, and seals will wear out over time (similar to brake pads on a car). Replacing the seals and changing the oil after three years may add longevity to the operation of the motor, saving you the cost of more expensive repairs. In warmer climates where the aerator runs most or all of the year, it is a good idea to replace seals more regularly than you would need to in colder climates where the unit is removed from the water for several months.

Sacrificial Anode

A sacrificial anode is supplied on the shaft of all aerators for protection of the equipment from corrosion and electrolysis. The anode should be updated (replaced) if reduced to half the original size or if white in color. Corrosion from electrolysis is more commonly associated with saltwater or brackish water, but as a matter of precaution, it is important to periodically check the anode in all installations (at least every two to three months). Seal replacement and all other repair services should be performed by Kasco Marine or a Kasco Authorized Repair Center. Any alterations or changes made to Kasco units by an unauthorized source will void the warranty. This includes tampering with the unit, power cord, and/or control box. Please contact Kasco Marine, Inc. at 715-262-4488 for your nearest Authorized Repair Center.

TROUBLESHOOTING TIPS

Below are some helpful troubleshooting tips. If a problem occurs, please double-check the assembly and installation instructions as well as the instructions for the control panel. More troubleshooting tips can be found at www.kascomarine.com

“My aerator trips the ground fault interrupter in the control panel.”

This is the most common symptom of several possible problems. To correctly diagnose the problem, you will need to collect more information. A Ground Fault Interrupter (GFI) breaker that trips can indicate an electrical service problem, water contamination in the unit and/or cord, bad breaker, control box problems, motor problems, etc. Try to find out the answers to these questions before you contact Kasco to narrow down the problem.

- How long does it take to trip the breaker?
- Does it always take the same amount of time to trip?
- How many times has it tripped?
- Have there been any recent electrical problems in the area?

“My aerator seems to run slowly.”

This can also be a symptom of several possible problems. There could be an electrical problem where the unit is not getting the proper voltage. This could also indicate a problem with the motor of the unit, which needs to be looked at by an Authorized Repair Center. Check that the unit is receiving the proper voltage, and, if so, contact Kasco for further steps.

TROUBLESHOOTING TIPS (CONT.)

“My aerator hums, but will not start. When I spin the prop with a stick, it starts up.”

(for single phase units only) This indicates a problem with the starting capacitor. Each Kasco aerator is equipped with a starting capacitor to get the unit going when it is first plugged in. If it is operating, but not spinning and can be started by spinning the prop with a stick, the starting capacitor needs to be replaced by an Authorized Repair Center.

“My aerator turns itself off and back on without the timer and without tripping the GFI breaker.”

(for single phase units only) Each Kasco unit has a thermal overload built in that will turn the unit off when it overheats. Once the unit has cooled down, it will start back up. If you are noticing these symptoms, the unit should be unplugged immediately because the thermal overload will continue to turn on and off until it burns out and damages the motor. The unit should be unplugged and taken out of the water to find the cause of the problem. The problem could be one of many, such as low water levels, build-up on the unit to prevent heat dissipation, something inhibiting the free rotation of the shaft, etc. If something is caught in the unit, or if there is buildup on the unit, remove the debris. If caught early enough, the unit should be fine. Contact a Kasco representative before restarting the unit.

“My aerator flow seems to fluctuate and/or be less than usual.”

This can occur because of a few different reasons. Most of the time, this symptom is caused by the unit being clogged with debris. A mat of weeds, many leaves, plastic bags, etc., can clog up the unit and cause it to be starved of water. If the unit does not have the proper amount of water, the flow or pattern will fluctuate up and down and look sporadic. If you are seeing these symptoms, first try turning off the unit and/or unplugging it for 10 seconds, allowing debris to fall away. If the problem persists, unplug the unit and clean away any debris that is clogging up the guard. Another possibility is a chipped or damaged prop that is causing the unit to wobble and not pump properly. When the unit is unplugged, check the prop and replace it if it is damaged.

“The GFI breaker trips randomly and sporadically. Sometimes it is after a few hours of operation; other times it can be days or weeks.”

This is referred to as a nuisance trip. This usually occurs where the unit is installed a great distance from the initial electric service on the property where the ground stake is placed. It is caused by either induced current in the ground wire or a base voltage difference due to soil pH levels. Contact an electrician and install a local grounding stake. This may eliminate the induced current and any base voltage differences.

REPLACEMENT PARTS (2HP)

ID	Description	Qty	Part #
A	Propeller (2HP)	1	820505
B	Sacrificial anode assembly (5/8" shaft)	1	840475
C	Cage	1	993200
D	3/8"-16 x 1-1/4" serrated flange screw	1	840543
E	3/8"-16 serrated flange nut	1	840532

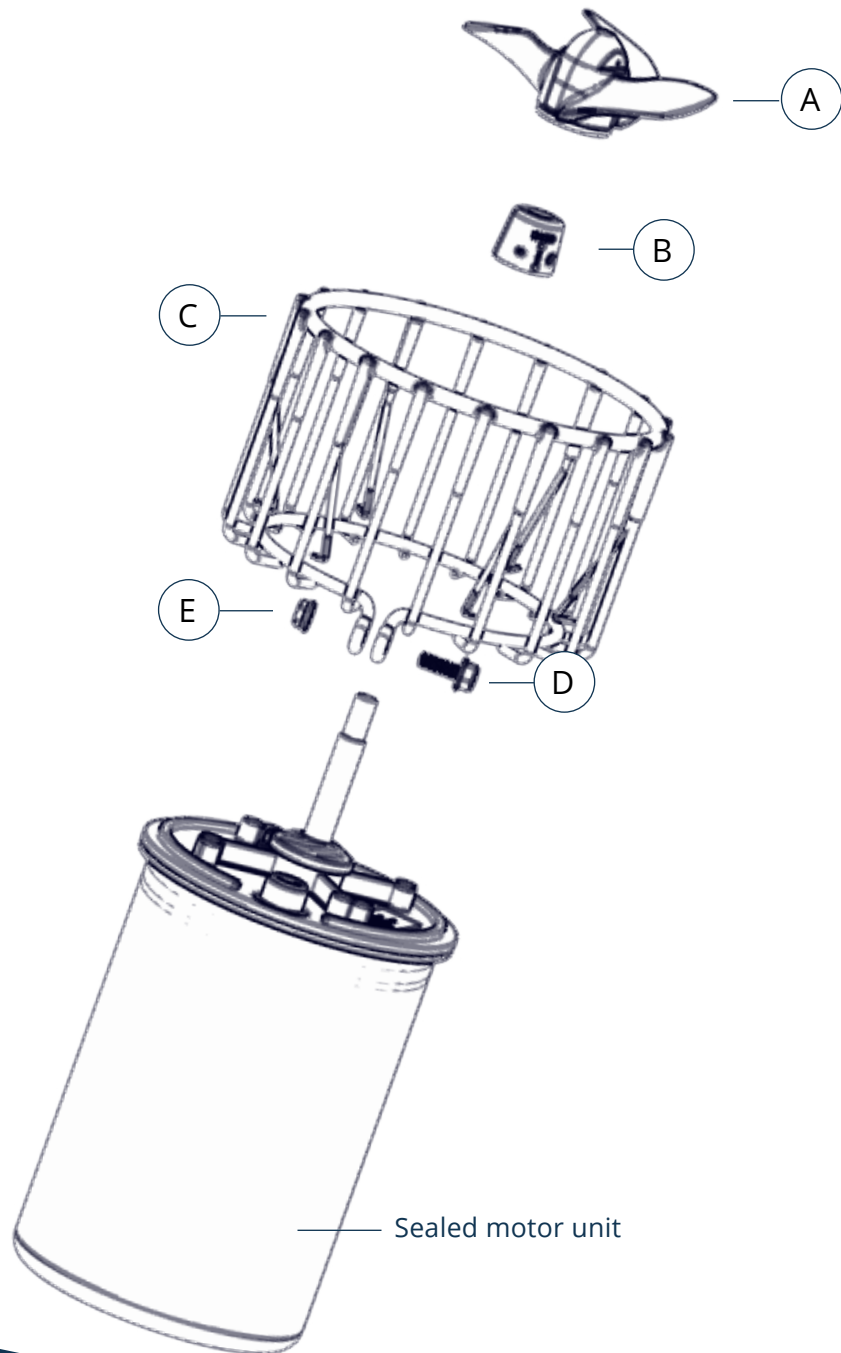

REPLACEMENT PARTS (3-5HP)

ID	Description	Qty	Part #
A	Propeller (3HP)	1	821213
A	Propeller (5HP)	1	821210
B	1/2" washer	1	475642
C	Sacrificial anode assembly (5/8" shaft)	1	840475
D	Aerator mounting ring	1	993300
E	Retaining clip	6	140312
F	1/4" flat washer	6	258476
G	1/4" split lock washer	6	840537
H	1/4"-20 x 3/4" hex head screw	6	840539

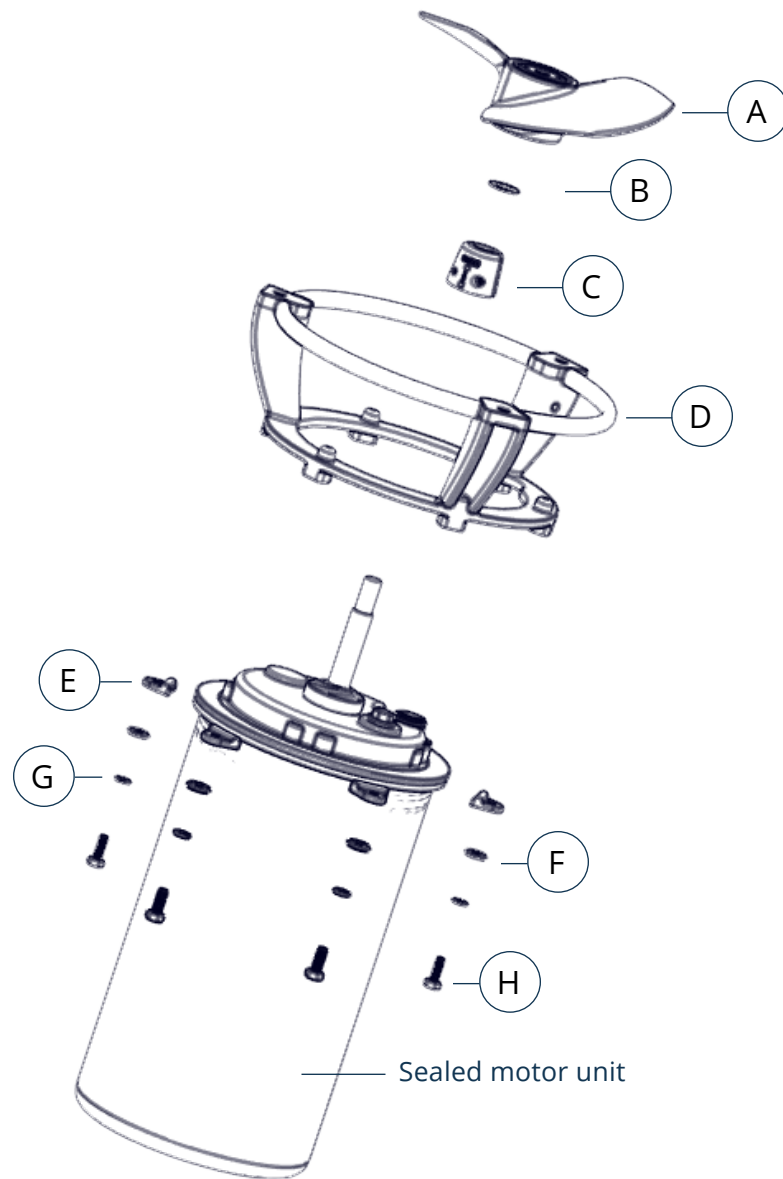

WARRANTY

Warranty Period: Models 8400AF, 2.3AF, 2.3HAF, 3.1AF, 3.3AF, 3.3HAF, 5.1AF, 5.3AF, 5.3HAF = 3 years

Kasco® Marine, Inc. warrants this aerator to be free from defects in material or workmanship (except for the ropes, power cord, and propeller) under normal use and service. The Kasco Marine, Inc. obligation under this warranty is limited to replacing or repairing free of charge any defective part within the warranty period. Customer shall pay shipping charges for returning the unit to Kasco or an Authorized Repair Center.

THIS WARRANTY IS IN LIEU OF ANY OTHER WARRANTIES, EXPRESSED OR IMPLIED, AND ANY OTHER OBLIGATION OR LIABILITY WHATSOEVER ON THE PART OF KASCO MARINE, INC. AND IN NO EVENT SHALL KASCO MARINE, INC. BE LIABLE FOR ANY SPECIAL OR CONSEQUENTIAL DAMAGES.

Warranty is void if:

- The unit is not maintained properly according to the Maintenance Recommendations supplied in this manual.
- The unit is returned for repair without the power cord or if the unit, control box, or power cord are altered in any way from original shipment. Cuts in the power cord are not covered under warranty.
- The unit is damaged by unauthorized tampering.
- The sacrificial anode around the propeller shaft shows significant deterioration. (The anode must be inspected periodically and replaced if necessary.)

Warranty Claim Procedure: The best method for establishing warranty period is via the original receipt. Also, register the unit online at: www.kascomarine.com. Once the warranty coverage has been established, the unit may be sent to any Kasco Authorized Repair Center for evaluation and repair. Please call Kasco Marine at 715-262-4488 prior to shipping to receive any updated information and/or repair form or call Kasco Marine at 715-262-4488 to locate your nearest Authorized Repair Center. You can also email Kasco at support@kascomarine.com.

Please include the repair form received from Kasco Marine or your local distributor with the shipment. If no repair form is available, include your name and physical address for return delivery of the repaired unit and a daytime phone number and/or e-mail address for correspondence regarding the warranty claim. Any expedited shipping method for the return of the unit is at the customer's expense. Kasco Marine will return units repaired under warranty at our expense via ground freight within the continental United States.

Other Repairs

Most failed equipment can be repaired at substantially lower costs than replacement with new. Please ship according to the instructions in the previous section.

Kasco Marine does estimates on repairs at the request of the customer. The request for an estimate should be included in the letter that accompanies the returned unit and must include a daytime phone number and/or e-mail address. Estimate options are as follows:

- We will contact the customer with a total estimated cost for repairs after we have evaluated the unit but before we perform the work.
- We will repair the unit only if repair costs are under a dollar amount stated by the customer. Example: "Please repair if total is under \$150.00 before shipping charges."

All estimates that are rejected for repair will be destroyed unless otherwise directed by the customer. If the customer would like the unit returned, the unit will be restored as closely as possible to the condition in which it was received and shipped at the customer's expense for shipping and handling charges.

Billing: Kasco Marine also accepts Visa and MasterCard credit card payments. Kasco Marine will call for credit card information upon completion of the estimate at the customer's request. All other warranty and repair inquiries should be directed to Kasco Marine, Inc. at 715-262-4488 or repairs@kascomarine.com



Kasco only accepts complete assemblies for warranty repair. We must receive the power cord and all other components with the motor as originally assembled. **THIS DOES NOT INCLUDE CONTROL PANEL, FLOAT, MOUNT, OR OTHER PARTS THAT CAM IN ADDITION TO THE MOTOR ASSEMBLY, UNLESS SPECIFICALLY REQUESTED BY A KASCO REPRESENTATIVE.** Kasco will bill the customer to replace any missing parts necessary for repair.

Please attach a repair form with the shipment. The repair form must include a name, physical address (for return delivery of the repaired unit), daytime phone number, and an e-mail address for correspondence regarding the warranty claim.

Any expedited shipping method for the return of the unit is at the customer's expense. Kasco Marine will return units repaired under warranty at our expense via ground freight within the continental United States.

CONTACT US



Kasco Marine
800 Deere Road
Prescott, WI 54021



715.262.4488



kascomarine.com | support@kascomarine.com



3020379
ANSI/UL 778: 2016
Ed.6+R:22Feb2017
CSA C22.2 #108: 2014 Ed.5

REPAIR CONTACT FORM

- Kasco requires that all equipment sent for repair MUST be accompanied by this form and marked to Repairs attention.
- Unit should be cleaned before shipping.
- Kasco is NOT responsible for shipping damage accrued in return shipment.
- It is the responsibility of the customer to ship and pay freight to Kasco.

Kasco Marine
 800 Deere Road
 Prescott, WI 54021
 Attn: Repairs

Note: Contact information should be that of the person or company to contact for repair information.

Company name			
Contact name	First name	Last name	
Address	Street		
	City		
	State		
	ZIP code		
Phone number	Primary	Alternate	
Email address			
Preferred method of contact (circle one)	Phone	Email	
Purchase order number			
Additional product information	Serial Number	Cord Length	
Information for Repair Technician			
Was this unit used in a chemical treatment or wastewater application? (circle one)	Yes	No	
Additional notes			