

# CertiSafe™ RM-100 FLOOR MOUNT

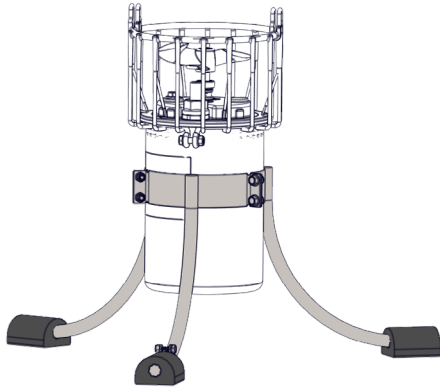

## OVERVIEW

- The RM-100 is a vertical orientation, stationary floor mount.
- Designed for use in ground storage tanks.
- Suitable for use with all CertiSafe™ Tank Mixer models

## INCLUDED

- 3-piece mixer base unit
- 50' 316 stainless steel retrieval chain
- 316 stainless chain lifting bail with spring
- Stainless tank penetration for power cord
- Stainless tank penetration hardware to suspend cable support and retrieval chain
- EPDM rubber feet

## REQUIRED

- Electrical service to exterior junction box



Certified to  
NSF/ANSI/CAN 61  
& 372

