

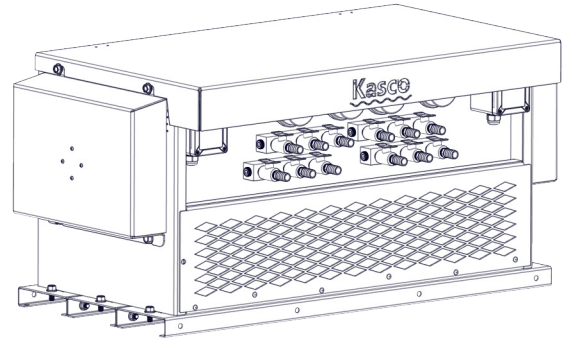

# ROBUSTAIRE DIFFUSED AERATION 50HZ LARGE CABINET SYSTEM

## OVERVIEW

- System includes rocking piston compressors, cabinet, diffusers
- Designed for 24-hour operation with minimal maintenance
- Compressed air inlet filter visual maintenance indicator
- Patent-pending noise-canceling design to dramatically reduce compressor sound



## COMPRESSOR

- Continuous-duty rated
- Ramped reed valve
- Heat-resistant tubing
- Paper air filter element for compressed air
- CE Certified

### Teich-Aire KM-120C

- 1/2HP oilless piston compressor
- 230V (KM-120HC) 2.0 amps @ 1.38 bar (20 psi)
- 4.9 CFM @ .34 bar (5 psi); 4.0 CFM @ 1.72 bar (25 psi)
- 1.72 bar (25 psi) pressure relief valve
- Can supply up to 3 diffuser heads

## SURESINK WEIGHTED TUBING

- Sold separately
- 1.59cm ID
- 30.48m rolls or 152.4m reels
  - 30.48m packages include all fittings

## OPTIONAL REMOTE MANIFOLD

- Aluminum manifold with brass valves

## LARGE CABINET

- Accommodates three or four 1/2HP compressors
- Powder-coated aluminum cabinet
- Ground pad installation recommended
- Cooling air filtered as it's drawn into cabinet
- 106.6cm x 52.5 x 49.8cm
- 3- & 4- compressor cabinet has two power cords with bare wires for hard wiring or attaching plugs

## DIFFUSER

- Self-weighted stainless steel base designed to land upright every time
- Integrated tubing strain relief & rope tie-offs
- Molded plastic edge guards protect pond lining
- Proprietary linear low-density polyethylene & rubber diffuser hose
- 58.4cm x 39.4cm assembled
- Diffuser hose sits 15cm above bottom of base
- Check valve

## WARRANTY

- Diffusers: Lifetime
- Cabinet: Lifetime
  - Exhaust fans: 3 years
- SureSink Tubing: 15 years
- Compressor
  - Motor: 3 years
  - Piston cups and cylinders: 2 years



# ROBUST-AIRE DIFFUSED AERATION LARGE CABINET SYSTEM

Model	Compressor	# of Diffusers	Voltage/Phase	Amps
RAE7	KM-120HC (1/2HP, x3)	7	220V / 1	5.25
RAE8	KM-120HC (1/2HP, x3)	8	220V / 1	5.25
RAE9	KM-120HC (1/2HP, x3)	9	220V / 1	5.25
RAE10	KM-120HC (1/2HP, x4)	10	220V / 1	7
RAE11	KM-120HC (1/2HP, x4)	11	220V / 1	7
RAE12	KM-120HC (1/2HP, x4)	12	220V / 1	7

## CABINET DIMENSIONS

