



# ROBUSTAIRE DIFFUSED AERATION 50Hz SMALL CABINET SYSTEM

## OVERVIEW

- System includes rocking piston compressor, cabinet, diffuser(s), weighted tubing
- Designed for 24-hour operation with minimal maintenance
- Compressed air inlet filter visual maintenance indicator
- Patent-pending noise-canceling design to dramatically reduce compressor sound

## COMPRESSOR

- Continuous-duty rated
- Ramped reed valve
- Heat-resistant tubing
- Paper air filter element for compressed air
- CE Certified

### Teich-Aire KM-60C

- 1/4HP oilless piston compressor
- 230V (KM-60HC) 1.6 amps @ 1.38 bar (20 psi)
- 3.4 CFM @ .34 bar (5 psi); 2.7 CFM @ 1.72 bar (25 psi)
- 1.72 bar (25 psi) pressure relief valve
- Can supply to 1 diffuser head

### Teich-Aire KM-120C

- 1/2HP oilless piston compressor
- 230V (KM-120HC) 2.0 amps @ 1.38 bar (20 psi)
- 4.9 CFM @ .34 bar (5 psi); 4.0 CFM @ 1.72 bar (25 psi)
- 1.72 bar (25 psi) pressure relief valve
- Can supply up to 3 diffuser heads

## SURESINK WEIGHTED TUBING

- Tubing included
- Cabinet equipped with 9.5mm barbs, 16mm barb kit available
- 30.48m rolls or 152.4m reels
  - 30.48m packages include all fittings

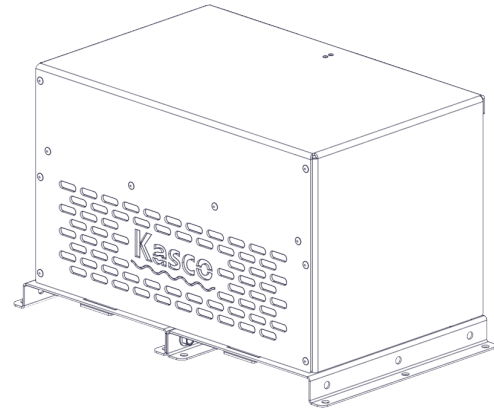

## OPTIONAL REMOTE MANIFOLD

- Aluminum manifold with brass valves

## SMALL CABINET

- Accommodates one 1/4 or 1/2HP compressor
- Powder-coated aluminum cabinet
- Ground pad installation recommended
- Optional Mounting Bracket available
- Cooling air filtered as it's drawn into cabinet
- 57.15cm x 43.18cm x 33.97cm
- 1 - compressor cabinet has one power cord with bare wires for hard wiring or attaching a plug

## DIFFUSER

- Self-weighted stainless steel base designed to land upright every time
- Integrated tubing strain relief & rope tie-offs
- Molded plastic edge guards protect pond lining
- Proprietary linear low-density polyethylene & rubber diffuser hose
- 58.4cm x 39.4cm assembled
- Diffuser hose sits 15cm above bottom of base
- Check valve

## WARRANTY

- Diffusers: Lifetime
- Cabinet: Lifetime
  - Exhaust fans: 3 years
- SureSink Tubing: 15 years
- Compressor
  - Motor: 3 years
  - Piston cups and cylinders: 2 years

**Kasco**<sup>®</sup>

# ROBUSTAIRE DIFFUSED AERATION SMALL CABINET SYSTEM

Model	Compressor(s)	# of Diffusers	Voltage/Phase	Amps
Standard Systems				
RAE1	KM-60HC (1/4HP x 1)	1	208-240V / 1	1.25
RAE2	KM-120HC (1/2HP x 1)	2	208-240V / 1	1.75
RAE3	KM-120HC (1/2HP x 1)	3	208-240V / 1	1.75

## CABINET DIMENSIONS WITHOUT POST MOUNT

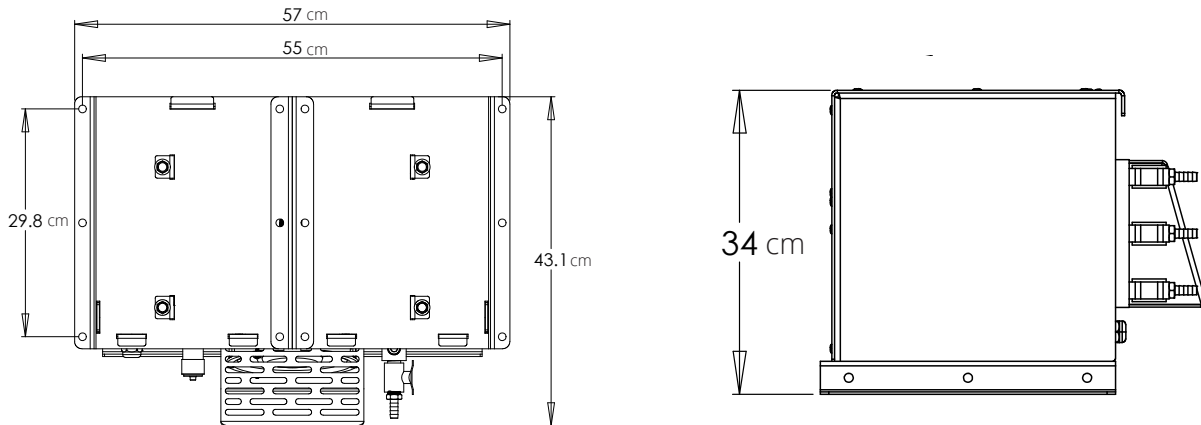

## CABINET DIMENSIONS WITH MOUNTING BRACKET

