

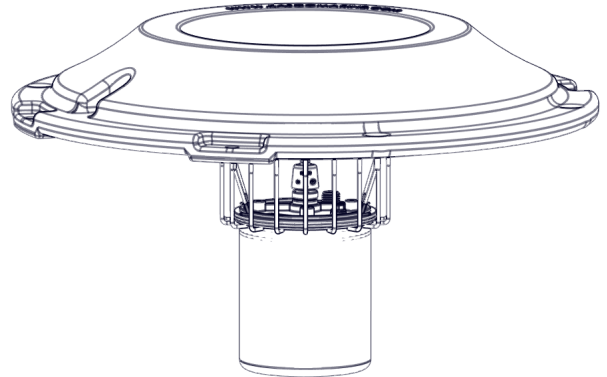

# 4400HAF SURFACE AERATOR

## OVERVIEW

- Complete package includes assembled motor unit, float, three mooring lines, and power cable.
- Operates in 19" (48cm) of water.
- Total package Listed by ETL to UL/CSA standards
- Corrosion protection for saltwater applications
- Intake near surface allows for shallow operation
- Optional lighting



## MOTOR UNIT

- 1HP, 208-240V, single phase
- 1750 RPM
- Oil cooled, continuous duty rated
- 17mm top and bottom bearings
- Thermal overload protection
- Fully unitized heavy-duty carbon ceramic mechanical seal
- Series 300 Austenitic stainless steel can with engineering grade thermoplastic top
- Sacrificial anode
- Custom-engineered UV-resistant thermoplastic 4-blade propeller

## POWER CABLE

- UL, CSA & NEC approved underwater rated cable
- 3 wire (L1, L2, G)
- Quick Disconnect standard on 12+ AWG cords
- Stainless steel strain relief on 12+ AWG cords
- 6' flex sleeving protection

## FLOAT

- UV-resistant linear low-density polyethylene
- Single piece float
- Series 300 coated stainless steel hardware
- Three 50' braided nylon mooring ropes
- Optional coated stainless steel bottom screen

## OPTIONAL CONTROL PANEL

- UL 508 Listed
- UL Type 3R/4X thermoplastic enclosure
- 20-Amp breaker
- GFCI protection with 5ma trip level
- 24-hour mechanical aerator timer
- Surge protector
- Use C85 panel if purchasing optional lighting

# 4400HAF SURFACE AERATOR

HP	Voltage / Phase / Hz	Running Amps	Locked Rotor Amps	Suggested Pond Size (SA)*	Min. Depth of Operation (in.)
1	208-240V / 1 / 60	4.4	20	Up to 1	19

\*Surface Acreage; also consider pond shape, depth, and oxygen demand.

## MODEL SPECIFICATIONS

Model	Cord Length	Cord Gauge
4400HAF050	50 ft.	14/3
4400HAF100	100 ft.	14/3
4400HAF150	150 ft.	12/3
4400HAF200	200 ft.	12/3
4400HAF250	250 ft.	12/3
4400HAF300	300 ft.	12/3
4400HAF400	400 ft.	12/3
4400HAF500	500 ft.	10/3

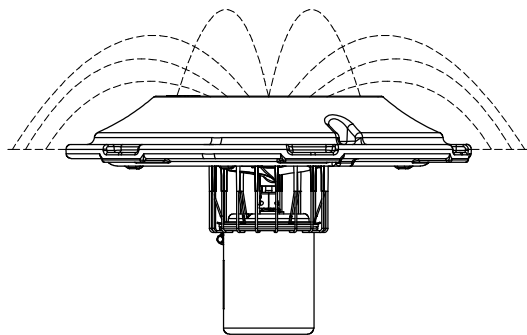

Unit + Pattern = 30" H x 50" W

