



5.3HAF SURFACE AERATOR

OVERVIEW

- Complete package includes assembled motor unit, float, three mooring lines, and power cable.
- Operates in 26" (66cm) of water.
- Total package Listed by ETL to UL/CSA standards
- Corrosion protection for saltwater applications
- Intake near surface allows for shallow operation
- Optional lighting



MOTOR UNIT

- 5HP, 460V, three phase
- 1750 RPM
- Oil cooled, continuous duty rated
- 17mm top and 20mm bottom bearings
- Fully unitized heavy-duty carbon ceramic mechanical seal
- Series 300 Austenitic stainless steel can
- Cast stainless steel motor top
- Sacrificial anode
- Custom-engineered UV-resistant thermoplastic 2-blade weedless propeller

POWER CABLE

- UL, CSA & NEC approved underwater rated cable
- 4 wire (L1, L2, L3, G)
- Quick Disconnect standard
- Stainless steel strain relief standard
- 6' flex sleeving protection standard, optional for entire cord length

FLOAT

- UV-resistant linear high-density thermoplastic
- Three-piece lap joint
- Series 300 coated stainless steel hardware
- Three 50' braided nylon mooring ropes
- Optional coated stainless steel bottom screen

CA-3050-H CONTROL PANEL (OPTIONAL WITH U MODELS)

- UL type 3R/4X thermoplastic enclosure
- UL 508 Listed
- GFCI protection with 30ma trip level
- Surge protector
- Motor starter with adjustable overload
- Hand-Off-Auto switch
- 24-hour mechanical aerator timer
- Terminal block wiring
- 5-wire power required (L1, L2, L3, N, G)
- Use CAL-3235-H if purchasing optional lighting

5.3HAF SURFACE AERATOR

| HP | Voltage / Phase / Hz | Running Amps | Locked Rotor Amps | Suggested Pond Size (SA)* | Min. Depth of Operation (in.) |
|----|----------------------|--------------|-------------------|---------------------------|-------------------------------|
| 5 | 460V / 3 / 60 | 6.5 | 49 | Up to 5 | 26" |

*Also consider pond shape, depth, and oxygen demand.

MODEL SPECIFICATIONS

| Model | Cord Length | Cord Gauge | Number of Boxes* | Shipping Weight* |
|-----------|-------------|------------|------------------|------------------|
| 5.3HAF100 | 100 ft. | 14/4 | 4 | 191 lbs. |
| 5.3HAF150 | 150 ft. | 14/4 | 4 | 202 lbs. |
| 5.3HAF200 | 200 ft. | 14/4 | 4 | 213 lbs. |
| 5.3HAF250 | 250 ft. | 14/4 | 4 | 224 lbs. |
| 5.3HAF300 | 300 ft. | 14/4 | 4 | 235 lbs. |
| 5.3HAF400 | 400 ft. | 12/4 | 4** | 280 lbs. |
| 5.3HAF500 | 500 ft. | 12/4 | 4** | 307 lbs. |

* Subtract 1 box and 19 lbs. for U models.

** Ships motor freight only.

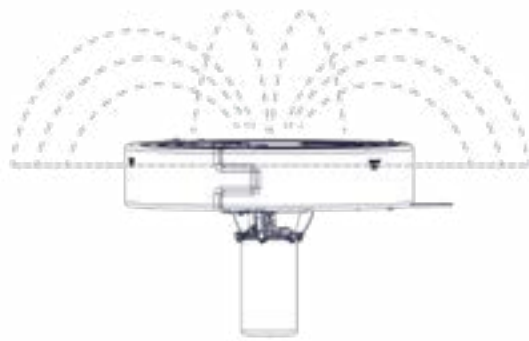

Pattern = 60" H x 148" W

